



TopKAT™ Fuel Management System

Installation Manual

Computer Programs and Documentation

All Gasboy computer programs (including software on diskettes and within memory chips) and documentation are copyrighted by, and shall remain the property of, Gasboy. Such computer programs and documents may also contain trade secret information. The duplication, disclosure, modification, or unauthorized use of computer programs or documentation is strictly prohibited, unless otherwise licensed by Gasboy.

Federal Communications Commission (FCC) Warning

This equipment has been tested and found to comply with the limits for a Class A digital device pursuant to Part 15 of the FCC Rules. These limits are designed to provide reasonable protection against harmful interference when the equipment is operated in a commercial environment. This equipment generates, uses, and can radiate radio frequency energy, and if not installed and used in accordance with the instruction manual, may cause harmful interference to radio communications. Operation of this equipment in a residential area is likely to cause harmful interference in which case the user will be required to correct the interference at his own expense. Changes or modifications not expressly approved by the manufacturer could void the user's authority to operate this equipment.

Approvals

Gasboy, Greensboro, is an ISO 9001:2000 registered facility.

Underwriters Laboratories (UL):

UL File#	Products listed with UL
MH4314	All dispensers and self-contained pumping units
MH6418	Power operated Transfer Pump Models 25, 25C, 26, 27, 28, 72, 72S, 72SP, 72X, 73 and 1820
MH7404	Hand operated Transfer Pump Models 1230 Series, 1243 Series, 1520 and 1720 Series
MH10581	Key control unit, Model GKE-B Series Card reader terminals, Models 1000, 1000P Site controller, Model 2000S CFN Series Data entry terminals, Model TPK-900 Series Fuel Point Reader System

New York City Fire Department (NYFD):

NYFD C of A #	Product
4823	9100A, 9140A, 9152A, 9153A, 9800A, 9840A, 9850A, 9852A, 9853A, 9140
4997	9822A, 9823A
5046	9100Q, 9140Q, 9152Q, 9153Q, 9800Q, 9840Q, 9852Q, 9853Q
5087	8753K, 8853K, 9153K, 9853K (restricted to diesel and non-retail gasoline sales)
5091	8752K, 9152K
5129	9122K, 9123K, 9822K, 9823K

California Air Resources Board (CARB):

Executive Order #	Product
G-70-52-AM	Balance Vapor Recovery
G-70-150-AE	VaporVac

National Conference of Weights and Measures (NCWM) - Certificate of Compliance (CoC):

Gasboy pumps and dispensers are evaluated by NCWM under the National Type Evaluation Program (NTEP). NCWM has issued the following CoC:

CoC#	Product	Model #	CoC#	Product	Model #	CoC#	Product	Model #
95-179	Dispenser	9100 Retail Series, 8700 Series, 9700 Series	91-019	Dispenser	9100 Commercial Series	05-002	Atlas	8700K, 8800K, 9100K, 9200K, 9800K
95-136	Dispenser	9800 Series	91-057	Controller	1000 Series FMS, 2000S-CFN Series			

Patents

Gasboy products are manufactured or sold under one or more of the following US patents:

Dispensers

5,257,720

Point of Sale/Back Office Equipment

D335,673

Additional US and foreign patents pending.

Trademarks

Non-registered trademarks

Atlas™
Console™
Infinity™

Registered trademarks

ASTRA®
Fuel Point®
Gasboy®
Keytrol®
Slimline®

Additional US and foreign trademarks pending.

Other brand or product names shown may be trademarks or registered trademarks of their respective holders.

Table of Contents

1 – Introduction	1
Purpose	1
Abbreviations and Acronyms	1
Description	2
General Information	2
Communication Ports	3
Using this Manual	4
Related Documents	4
Warranty	4
2 – Important Safety Information	5
3 – FCC and DOC Customer Information	9
FCC Part 15	9
FCC Part 68	9
General Requirements for All Equipment	9
DOC Certification	10
4 – General Installation	11
Rules for Proper Installation	11
Component Location and Installation Specifications	12
System	12
Data Terminal	12
External Modem	12
Internal Modem	13
Power Conditioner	13
Conduit Layout/Installation Specifications	14
Conduit Requirements	14
Power Requirements	16
AC Power to the TopKAT System	16
TopKAT Peripheral Equipment	16
Grounding	16
Suction Pumps	17
Dispensers	17
Wire Size	17
Mechanical Interface Option	18
Communication Requirements	19
RS-485 - ASTRA and Mechanical PCUs	19
RS-485 - Master/Satellite Option	19
RS-485 - Standalone TopKAT System or Wall-Mount PCU	20
RS-232	21
RS-232 - Termination Box	22
RS-422 - SHMs	22
Terminal Block ID	24
5 – Series 9820 ASTRA Installation	25

Description	25
ASTRA to TopKAT Cabling	27
Port Communication Wiring	28
TopKAT Master/Satellite Communications Wiring	30
Wiring for a CRT Terminal and Okidata Printer	31
Wiring for Modems	31
External Modems	31
Internal Modem	31

6 – TopKAT Master/Satellite 33

Description	33
Wiring for Modems	38
External Modems	38
Internal Modems	38

7 – Mechanical Interface Option 39

Description	39
Dimensions	40
Conduit Layout	41
Terminal Block ID	42
System Pump and Dispenser Wiring	43
Wiring Precautions	43
Control Lines for Mechanical Pumps/Dispensers	44
Grounding	44
Reset Motor Feed	44
Pump Motor Feed	44
Neutral Feed	44
Submersible Feed, Submersible Drive	45
Reset Complete (Switch Detect)	45
Light Feed	45
Light Neutral	45
Phase 2 Feed	45
Pulser - Mechanical Pump	45
Control Lines for Gasboy 9800 or 9820 Electronic Pumps/Dispensers	46
Ground	46
Micro Feed	46
Micro Neutral	46
Control/Pump Motor Feed	47
External Valve	47
Neutral Feed	47
Control/Submersible Feed (Control/Subm Feed)	47
Submersible Starter Drive (Subm Starter Drive)	48
Submersible Drive (Subm Drive)	48
Reset Complete (Switch Detect)/Slow Flow	48
Phase 2 Feed	48
Light Feed	48
Light Neutral	49
Pulser - 9800/9820	49
Wiring Diagrams	50
Pulser Wiring Notes	50
Wiring for Modems	73
External Modems	73
Internal Modem	73

8 – Mechanical PCU Option	75
----------------------------------	-----------

Description	75
PCU Dimensions and Layouts	75
Terminal Block ID	80
Pump Control EXPMUX CPU Board	84
Pump Control I/O PCB	87
System Pump and Dispenser Wiring	89
Wiring Precautions	89
Control Lines for Mechanical Pumps/Dispensers	90
Grounding	90
Reset Motor Feed	90
Pump Motor Feed	90
Neutral Feed	91
Submersible Feed, Submersible Drive	91
Reset Complete (Switch Detect)	91
Light Feed	91
Light Neutral	91
Phase 2 Feed	91
Pulser - Mechanical Pump	91
Wiring Diagrams: Pulsers, Pumps, Dispensers	92
Pulser Wiring Notes	94
Wiring Diagrams: Port Communication	105
TopKAT Master/Satellite Communications Wiring	108
Wiring for a CRT Terminal and Okidata Printer	109
Wiring for Modems	109
External Modems	109
Internal Modem	109

9 – Series 9800 Field Installation	111
-------------------------------------------	------------

Description	111
Conduit Layout	113
Series 9800 to TopKAT Cabling	114
Port Communication Wiring	115
TopKAT Master/Satellite Communications Wiring	118
Wiring for a CRT Terminal and Okidata Printer	119
Wiring for Modems	119
External Modems	119
Internal Modem	119

10 – Wireless Communications Installation	121
--------------------------------------------------	------------

11 – Serial-to-LAN Connection Installation	123
---------------------------------------------------	------------

12 – Testing	125
---------------------	------------

Completion Check List	125
Manual Override Test - 2-hose Mechanical Interface Option	126
Manual Override Test - 4-hose Mechanical PCU Option	127

Appendix A: Base Layout for Shelf Mounting	A-1
---------------------------------------------------	------------

Appendix B: Atlas CPU Board Jumper Settings	B-1
Old Style (C09634)	B-1
Switch Settings	B-1
New Style CPU (M06333)	B-1
Index	Index-1

1 – Introduction

Purpose

The Gasboy® Series 900 TopKAT™ Installation Manual is provided to assist you in installing the TopKAT system. This manual should be supplied to the electrician prior to the installation of the conduit and wiring to ensure that the TopKAT System is installed properly. Faulty installations are the major cause of system malfunctions. The TopKAT system must be installed exactly as described in this manual to ensure its reliability and proper operation.

Note: Gasboy provides a toll-free number for customers and installers who may have questions pertaining to the installation: 1-800-444-5529.

Abbreviations and Acronyms

Term	Description
AC	Alternating Current
CRT	Cathode Ray Tube
DC	Direct Current
DOC	Department of Communication
FMS	Fuel Management System
FCC	Federal Communications Commission
ICR	Island Card Reader
LAN	Local Area Network
LCD	Liquid Crystal Display
PCB	Printed Circuit Board
PCU	Pump Control Unit
PIN	Personal Identification Number
PVC	Polyvinyl Chloride
RAM	Random Access Memory
REN	Ringer Equivalence Number
SHM	Short Haul Modem
UL®	Underwriters Laboratories

Description

General Information

Figure 1-1: Typical TopKAT Installation



Figure 1-2: TopKAT Dimensions

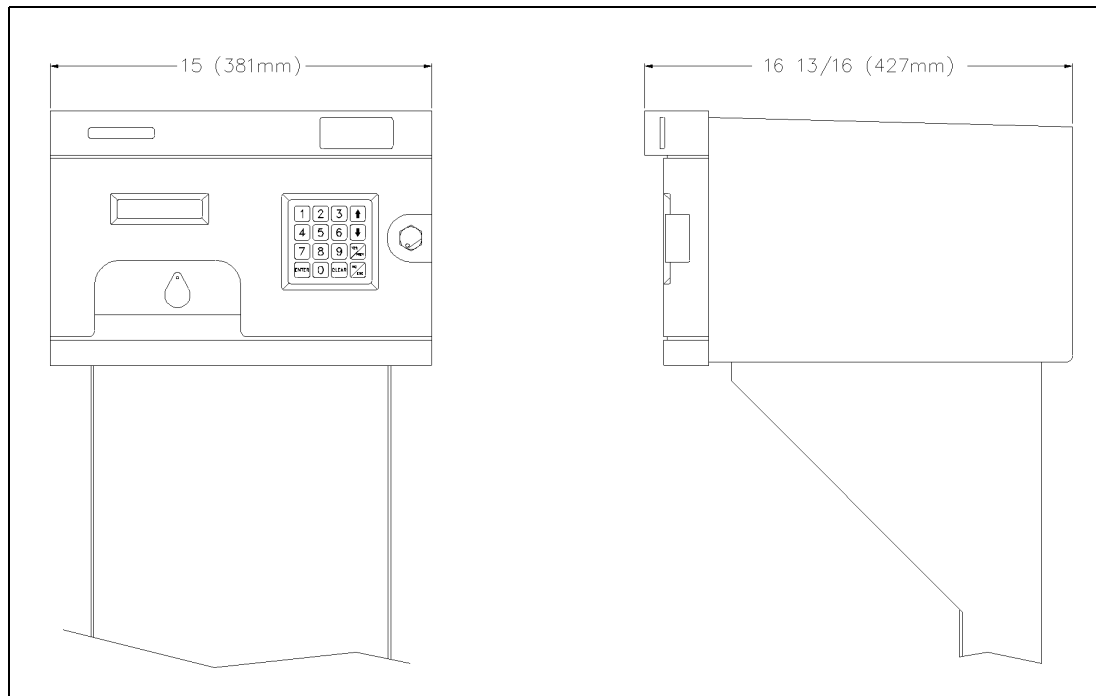

The Gasboy Series 900 TopKAT is a microprocessor-based fuel control and data acquisition system. The TopKAT system is totally self-contained in a rugged, well-designed, and attractive weatherized cabinet. It is mounted on one of the following:

- 9800 pump/dispenser
- 9820 ASTRA® pedestal
- Pedestal

A standalone TopKAT system can control up to eight electronic hoses or two mechanical hoses. A master/satellite option allows multiple units to be linked together, with one acting as the master controlling unit. If you have the master/satellite option, you can control the following:

- Up to eight electronic hoses and seven satellite readers
- Up to 16 mechanical hoses (two hoses per TopKAT)
- One 9820 or 9800 single or twin electronic hose and up to 14 mechanical hoses (two hoses per TopKAT).

A standalone or master/satellite with a mechanical Pump Control Unit (PCU) option can control up to eight mechanical hoses (four hoses per PCU and up to two pedestal or wall-mounted PCUs).

The TopKAT is equipped with a data key receptacle. Visual prompting messages that are displayed on the Liquid Crystal Display (LCD) guide the user through the steps required to activate the pump/dispenser. The display is backlit so that it can be read at night. A 16-position membrane keypad is provided on the face of the unit to enter data such as Personal Identification Number (PIN), odometer reading, pump selection, and so on. The unit may also be equipped with an optional report printer.

The front bezel and rear of the cabinet are hinged doors secured with locks to prohibit unauthorized access. The front bezel allows access to the optional report printer and paper. The one-piece hood can be removed for total accessibility during installation and servicing. When installing the system, ensure that you provide adequate clearance to allow easy access to both front and rear doors for servicing.

Communication Ports

The TopKAT system contains three asynchronous ports. Typically, Port 1 is used for communications to a 9800, ASTRA, or Mechanical PCU via RS-485 lines. Ports 2 and 3 can be set for either RS-232 or RS-422 communications to a data terminal or computer. Refer to the port wiring diagrams in [“Communication Requirements”](#) on [page 19](#) for your specific type of installation. Communication is through direct wire, or by dial-up phone lines using an optional built-in modem.

If the TopKAT system is equipped with the master/satellite option, the master is the only unit that will need to have a data communication link. This will collect all transactions and maintain the complete data base for the entire site. Refer to [“RS-485 - Master/Satellite Option”](#) on [page 19](#) for more communication requirements.

If the TopKAT is equipped with the wireless option, refer to [“Wireless Communications Installation”](#) on [page 121](#) and MDE-4520 Enhanced Communications Installation Manual.

Using this Manual

The TopKAT system can be installed in the following ways:

- Mounted on a pedestal with a Series 9820 ASTRA
- Mounted on a free-standing pedestal for use with mechanical pumps, electronic 9800s or ASTRAs
- As part of a master/satellite configuration
- Mounted atop a 9800 pump/dispenser
- Mounted on a freestanding pedestal, for use with internal 4-hose Mechanical PCUs or external wall-mounted 4-hose Mechanical PCUs.

Note: The 4-hose mechanical PCU option is referred to as the Mechanical PCU option in this manual; the 2-hose Mechanical Interface is called the Mechanical Interface option.

Related Documents

The following manuals provide additional information about the TopKAT Fuel Management System (FMS).

Document Number	Title	GOLD Library
C35965	TopKAT Host Communications Manual	Series 1000/Fleetkey and TopKAT
MDE-4338	TopKAT Operation Manual	Series 1000/Fleetkey and TopKAT
MDE-4490	PC/TopKAT User's Guide	CFN Series Controllers and POS
MDE-4520	Enhanced Communications Installation Manual	RFID Wireless and TCP/IP Equipment
PT-1957	TopKAT Parts Manual	CFN Series Controllers and POS

Warranty

For information on warranty, refer to MDE-4255 Gasboy's Warranty Policy Statement. If you have any warranty-related questions, contact Gasboy's Warranty Department at its Greensboro location.

2 – Important Safety Information



This section introduces the hazards and safety precautions associated with installing, inspecting, maintaining or servicing this product. Before performing any task on this product, read this safety information and the applicable sections in this manual, where additional hazards and safety precautions for your task will be found. Fire, explosion, electrical shock or pressure release could occur and cause death or serious injury, if these safe service procedures are not followed.

Preliminary Precautions

You are working in a potentially dangerous environment of flammable fuels, vapors, and high voltage or pressures. Only trained or authorized individuals knowledgeable in the related procedures should install, inspect, maintain or service this equipment.

Emergency Total Electrical Shut-Off

The first and most important information you must know is how to stop all fuel flow to the pump/dispenser and island. Locate the switch or circuit breakers that shut off all power to all fueling equipment, dispensing devices, and Submerged Turbine Pumps (STPs).

 WARNING	
	The EMERGENCY STOP, ALL STOP, and PUMP STOP buttons at the cashier's station WILL NOT shut off electrical power to the pump/dispenser. This means that even if you activate these stops, fuel may continue to flow uncontrolled.
	
You must use the TOTAL ELECTRICAL SHUT-OFF in the case of an emergency and not the console's ALL STOP and PUMP STOP or similar keys.	

Total Electrical Shut-Off Before Access

Any procedure that requires access to electrical components or the electronics of the dispenser requires total electrical shut off of that unit. Understand the function and location of this switch or circuit breaker before inspecting, installing, maintaining, or servicing Gasboy equipment.

Evacuating, Barricading and Shutting Off

Any procedure that requires access to the pump/dispenser or STPs requires the following actions:



- An evacuation of all unauthorized persons and vehicles from the work area
- Use of safety tape, cones or barricades at the affected unit (s)
- A total electrical shut-off of the affected unit (s)

Read the Manual

Read, understand and follow this manual and any other labels or related materials supplied with this equipment. If you do not understand a procedure, call a Gasboy Authorized Service Contractor or call the Gasboy Service Center at 1-800-444-5529. It is imperative to your safety and the safety of others to understand the procedures before beginning work.

Follow the Regulations

Applicable information is available in National Fire Protection Association (NFPA) 30A; *Code for Motor Fuel Dispensing Facilities and Repair Garages*, NFPA 70; *National Electrical Code (NEC)*, Occupational Safety and Hazard Association (OSHA) regulations and federal, state, and local codes. All these regulations must be followed. Failure to install, inspect, maintain or service this equipment in accordance with these codes, regulations and standards may lead to legal citations with penalties or affect the safe use and operation of the equipment.

Replacement Parts

Use only genuine Gasboy replacement parts and retrofit kits on your pump/dispenser. Using parts other than genuine Gasboy replacement parts could create a safety hazard and violate local regulations.

Safety Symbols and Warning Words

This section provides important information about warning symbols and boxes.

Alert Symbol



This safety alert symbol is used in this manual and on warning labels to alert you to a precaution which must be followed to prevent potential personal safety hazards. Obey safety directives that follow this symbol to avoid possible injury or death.

Signal Words

These signal words used in this manual and on warning labels tell you the seriousness of particular safety hazards. The precautions below must be followed to prevent death, injury or damage to the equipment:



DANGER: Alerts you to a hazard or unsafe practice which will result in death or serious injury.



WARNING: Alerts you to a hazard or unsafe practice that could result in death or serious injury.



CAUTION with Alert symbol: Designates a hazard or unsafe practice which may result in minor injury.

CAUTION without Alert symbol: Designates a hazard or unsafe practice which may result in property or equipment damage

Working With Fuels and Electrical Energy

Prevent Explosions and Fires

Fuels and their vapors will explode or burn, if ignited. Spilled or leaking fuels cause vapors. Even filling customer tanks will cause potentially dangerous vapors in the vicinity of the dispenser or island.

Important Safety Information

No Open Fire



Open flames from matches, lighters, welding torches or other sources can ignite fuels and their vapors.

No Sparks - No Smoking



Sparks from starting vehicles, starting or using power tools, burning cigarettes, cigars or pipes can also ignite fuels and their vapors. Static electricity, including an electrostatic charge on your body, can cause a spark sufficient to ignite fuel vapors. Every time you get out of a vehicle, touch the metal of your vehicle, to discharge any electrostatic charge before you approach the dispenser island.

Working Alone

It is highly recommended that someone who is capable of rendering first aid be present during servicing. Familiarize yourself with Cardiopulmonary Resuscitation (CPR) methods, if you work with or around high voltages. This information is available from the American Red Cross. Always advise the station personnel about where you will be working, and caution them not to activate power while you are working on the equipment. Use the OSHA Lockout/ Tagout procedures. If you are not familiar with this requirement, refer to this information in the service manual and OSHA documentation.

Working With Electricity Safely

Ensure that you use safe and established practices in working with electrical devices. Poorly wired devices may cause a fire, explosion or electrical shock. Ensure that grounding connections are properly made. Take care that sealing devices and compounds are in place. Ensure that you do not pinch wires when replacing covers. Follow OSHA Lockout/ Tagout requirements. Station employees and service contractors need to understand and comply with this program completely to ensure safety while the equipment is down.

Hazardous Materials

Some materials present inside electronic enclosures may present a health hazard if not handled correctly. Ensure that you clean hands after handling equipment. Do not place any equipment in the mouth.

WARNING

The pump/dispenser contains a chemical known to the State of California to cause cancer.

WARNING

The pump/dispenser contains a chemical known to the State of California to cause birth defects or other reproductive harm.

In an Emergency

Inform Emergency Personnel

Compile the following information and inform emergency personnel:

- Location of accident (for example, address, front/back of building, and so on)
- Nature of accident (for example, possible heart attack, run over by car, burns, and so on)
- Age of victim (for example, baby, teenager, middle-age, elderly)
- Whether or not victim has received first aid (for example, stopped bleeding by pressure, and so on)
- Whether or not a victim has vomited (for example, if swallowed or inhaled something, and so on)

WARNING



Gasoline ingested may cause unconsciousness and burns to internal organs.

Do not induce vomiting.
Keep airway open.
Oxygen may be needed at scene.
Seek medical advice immediately.

WARNING



Gasoline inhaled may cause unconsciousness and burns to lips, mouth and lungs.

Keep airway open.
Seek medical advice immediately.

WARNING



Gasoline spilled in eyes may cause burns to eye tissue.

Irrigate eyes with water for approximately 15 minutes.
Seek medical advice immediately.

WARNING



Gasoline spilled on skin may cause burns.



Wash area thoroughly with clear water.
Seek medical advice immediately.

IMPORTANT: Oxygen may be needed at scene if gasoline has been ingested or inhaled. Seek medical advice immediately.

Lockout/Tagout

Lockout/Tagout covers servicing and maintenance of machines and equipment in which the unexpected energization or start-up of the machine(s) or equipment or release of stored energy could cause injury to employees or personnel. Lockout/Tagout applies to all mechanical, hydraulic, chemical or other energy, but does not cover electrical hazards. Subpart S of 29 CFR Part 1910 - Electrical Hazards, 29 CFR Part 1910.333 contains specific Lockout/ Tagout provision for electrical hazards.

Hazards and Actions

 WARNING	
	Spilled fuels, accidents involving pumps/dispensers, or uncontrolled fuel flow create a serious hazard.
	Fire or explosion may result, causing serious injury or death. Follow established emergency procedures.

The following actions are recommended regarding these hazards:

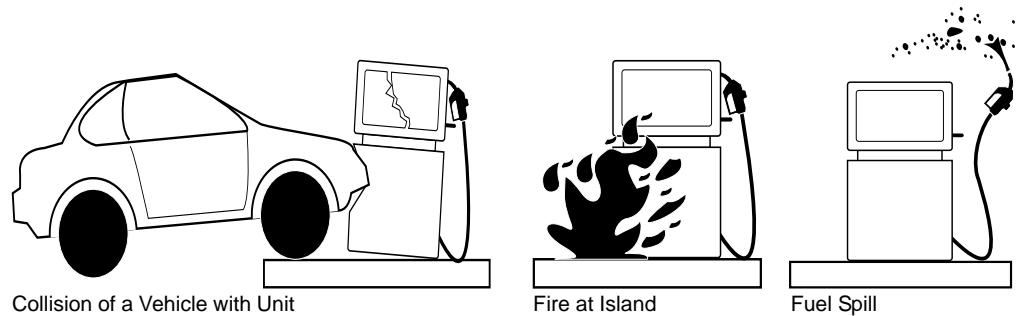

- Do not go near a fuel spill or allow anyone else in the area.
- Use station EMERGENCY CUTOFF immediately. Turn off all system circuit breakers to the island(s).
- Do not use console E-STOP, ALL STOP and PUMP STOP to shut off power. These keys do not remove AC power and do not always stop product flow.
- Take precautions to avoid igniting fuel. Do not allow starting of vehicles in the area. Do not allow open flames, smoking or power tools in the area.
- Do not expose yourself to hazardous conditions such as fire, spilled fuel or exposed wiring.
- Call emergency numbers.

This page is intentionally left blank.

3 – FCC and DOC Customer Information

Both the US Federal Communications Commission (FCC) and the Canadian Department of Communication (DOC) require that specific information be supplied to the users of any equipment that may emit radio frequency energy. Read the following information for details.

FCC Part 15

This equipment has been tested and found to comply with the limits for a Class A digital device, pursuant to Part 15 of FCC rules. These limits are designed to provide reasonable protection against harmful interference when the device is operated in a commercial environment. This equipment generates, uses, and can radiate radio frequency energy and, if not installed in accordance with the instruction manual, may cause harmful interference to radio communications. Operation of this equipment in a residential area is likely to cause harmful interference, in which case, users will be required to correct the interference at their own expense.

FCC Part 68

General Requirements for All Equipment

- This equipment complies with Part 68 of the FCC rules. The Gasboy Internal Modem is contained within a Gasboy FMS. On the outside of the rear access door of the FMS is a label that contains, among other information, the FCC registration number and Ringer Equivalence Number (REN) for this equipment. If requested, this information must be provided to the telephone company.
- The Gasboy Internal Modem should be connected to a USOC RJ-11C jack.
- An FCC-compliant telephone cord and modular plug is provided with the equipment. This equipment is designated to be connected to the telephone network or premises wiring using a compatible modular jack, which is Part 68 compliant.
- The REN is used to determine the quantity of devices that may be connected to the telephone line. Excessive RENs on the telephone line may result in the device not ringing in response to an incoming call. In most, but not all areas, the sum of RENs should not exceed five (5.0). To be certain of the number of devices that may be connected to a line, as determined by the total RENs, contact the local telephone company.
- If the Gasboy Internal Modem causes harm to the telephone network, the telephone company will notify you in advance that temporary discontinuance of service may be required. But if the advance notice is not practical, the telephone company will notify the customer as soon as possible. Also, you will be advised of your right to file a complaint with the FCC if you believe it is necessary.
- The telephone company may make changes in its facilities, equipment, operations or procedures that could affect the operation of the equipment. If such a case, the telephone company will provide advance notice for you to make necessary modifications to maintain uninterrupted service.

- If trouble is experienced with the Gasboy Internal Modem, contact Gasboy at 1-800-444-5529 for repairs or warranty information. If the equipment is causing harm to the telephone network, the telephone company may request that you disconnect the equipment until the problem is resolved.
- The Gasboy Internal Modem does not have any easily repairable or replaceable parts. Contact Gasboy in case you are experiencing trouble.
- The equipment cannot be used on the public coin phone service provided by the telephone company. Connection to the party line service is subject to state tariffs. (Contact your state Public Utility Commission, Public Service Commission or Corporation Commission for information).

DOC Certification

Industry Canada Ringer Equivalence Number Notice

The Canadian Department of Communications label identifies the certified equipment. This certification indicates that the equipment meets certain telecommunications network protective, operational, and safety requirements. The department does not guarantee that the equipment will operate to the user's satisfaction.

Before installing this equipment, you should ensure that it is permissible to be connected to the facilities of the local telecommunications company. The equipment must also be installed using an acceptable method of connection. In some cases, the company's inside wiring associated with a single line individual service may be extended by means of a certified connector assembly (telephone extension cord). The customer should be aware that compliance with the above condition may not prevent degradation of the service in some situations.

Repairs to the certified equipment should be made by an authorized maintenance facility designated by the supplier. Any repairs or alterations made to this equipment, or equipment malfunctions may give the telecommunications company cause to request you to disconnect the equipment.

You should ensure for your protection that the ground connections of the power utility, telephone lines and internal metallic water pipe system are connected together. This precaution may be particularly important in rural areas.

CAUTION

Users should not attempt to make such connections themselves and should contact the electric inspection authority or electrician, as appropriate.

The REN assigned to each terminal device denotes the percentage of the total load to be connected to a telephone loop that is used by the device, to prevent overloading. The termination on a loop may consist of any combination of devices subject only to the requirement that the total of the REN of all devices does not exceed five.

The REN for the Gasboy Internal Modem is 0.8B.

4 – General Installation

Rules for Proper Installation

WARNING

To reduce the risk of electrical shock when servicing, turn off all power to the pump/remote dispenser. In submersible pump applications, turn off all power to the submersible pump and any other remote dispensers that use the submersible pump. AC power can feed back into a shut-off remote dispenser when dispensers share a common submersible pump or starter relay.

AVERTISSEMENT

Pour réduire le risque de choc électrique lors de l'entretien/révision, coupez totalement le courant à la pompe/distributeur éloigné. Dans les applications de pompe immerisible, coupez totalement le courant à la pompe immerisible et tous autres distributeurs éloigné qui utilisent la pompe immerisible. Le courant alternatif peut alimenter de nouveau un distributeur éloigné à l'arrêt quand les distributeurs partagent une pompe immerisible commune ou un relais de démarrage.

To ensure proper installation, follow these rules:

- Read this entire manual before starting installation.
- Internationally and domestically: All wiring is to be installed and used in accordance with all applicable national, state, and local building/fire/electrical codes. Additionally, in the USA, installations must comply with the National Electrical Code (NFPA 70), NFPA 30, and the Automotive and Marine Service Station Code (NFPA 30A) codes and regulations. Canadian installations must comply with the Canadian Electrical Code.
- All wiring must be in a threaded, rigid, metal conduit to provide the necessary shielding. DO NOT use a PVC conduit.
- High-voltage AC and low-voltage DC must not be combined in a common conduit, Junction box, or wire trough unless the cable is used as specified in “RS-422 - SHMs” on [page 22](#).
- Power for the TopKAT system (when used with a mechanical interface), data terminal, and external modem must come from a separate, dedicated, circuit breaker.
- The TopKAT system and peripheral equipment must be properly grounded.
- Use terminal connectors on stranded wire.
- Test pumps in the manual override position prior to the startup of the system.
- DO NOT turn on the system power switch located in the head assembly. Power will be applied to the system by the person performing the system startup. Turning on this switch prematurely may result in damage to the system and may void your warranty.
Note: When the TopKAT system is supplied with a Mechanical Pump Interface (2-hose Mechanical or 4-hose PCU), it is necessary to turn on system power in order to test. Refer to “Testing” on [page 125](#) for more details.
- Check through all boxes and cartons for manuals, cables, connectors, and so on before disposing them off.

Component Location and Installation Specifications

Careful planning for the layout of the site will help eliminate possible problems with the startup of your system and will ensure continued, reliable system operation.

System

Regardless of your installation option, the TopKAT system must be located on the fuel island. The unit has been designed to withstand an environment of -22° F to 122° F (-30° C to 50° C), 95% relative humidity (non-condensing). When mounting the unit, a minimum clearance of 18 inches between the post and any of the pumps or dispensers must be maintained. This clearance meets the NFPA 30A and NFPA 70 requirements and allows room for the wiring and maintenance of the system. Adequate clearance around the head of the unit is important to provide room for the maintenance of the system. A minimum of 14 inches of clearance from the rear of the unit must be provided to allow the rear door to open.

Data Terminal

When a data terminal is used with the system it must be UL-listed and should be located in a clean, office type of environment. Do not install the data terminal over a hazardous location. Data terminals supplied by Gasboy have an operative temperature range of 32° F to 104° F (0° C to 40° C). Locating the terminal in a dirty environment may cause premature failure. Refer to [“Port Communication Wiring”](#) on [page 28](#) for your installation type to connect the data terminal.

External Modem

When an external modem is used with the system it must be UL-listed and should be located in an office type of environment. However, if this is not possible, it should be housed in a protective enclosure. Do not install the modem over a hazardous location. External modems supplied by Gasboy have an operative temperature range of 32° F to 104° F (0° C to 40° C). The type of phone line required for communication via an external modem is dependant on the type of modem used and the method of communication desired. Consult the manual that comes with the modem for specific requirements. Refer to [“Port Communication Wiring”](#) on [page 28](#) for your installation type to connect the external modem.

Internal Modem

When the TopKAT system is equipped with the optional internal modem, the Port 3 communication is routed through the modem in place of being wired at the DC Junction box. Jumper K2 should be removed. Refer to “Terminal Block ID” on page 24 for the location of jumpers K1 and K2. The phone line for the internal modem can be installed in the DC conduit. If you are installing the phone line in a DC conduit, the cable must be two twisted-pair shielded cables as specified in “Communication Requirements” on page 19 and the shield drain wire must be connected to the system AC ground. Check with your local phone company for proper installation of the phone line.

If you order your TopKAT system with an optional internal modem, the modem is mounted within the TopKAT system at the factory and power for the modem is supplied by the TopKAT system. The 2400 baud modem is designed for 300, 1200, or 2400 baud, full duplex, asynchronous communication. The 33600 baud modem is designed for 1200, 2400, or 9600 baud, full duplex, asynchronous communication. This modem meets or exceeds the direct connection registration requirements of the FCC rules. The modem will connect directly through a phone line supplied by the phone company. The customer is required to order this phone line and have it installed.

To order this equipment from the phone company, specify:

- 1 The registration number of 6BHUSA-24793-DT-E.
- 2 The data transmission rate of 300 baud, 1200 baud, 2400 baud, or 9600 baud.
- 3 The Bell equivalent of 103J/212A.

Power Conditioner

When used, a UL-listed power conditioner helps provide clean power to the TopKAT system. Poor power conditions are a key cause to system malfunction or failure. The power conditioner provides transient and common mode protection for the TopKAT system, although it cannot totally compensate for extremely poor power conditions. The power conditioner must be located in an area protected from direct contact with the weather (typically near the system circuit breakers) and should be no further than 50 feet from the TopKAT system for optimum protection. It must not be used over a hazardous location.

When used with a TopKAT system that is installed on a 9800 or ASTRA, the Micro Feed line from the pump/dispenser is routed through the power conditioner and then to the breaker. With a mechanical installation, the TopKAT system is directly connected to the power conditioner and then to the breaker. The power conditioner is designed for an operating temperature range of -20° C to 48° C.

Conduit Layout/Installation Specifications

- Internationally and domestically: All wiring must be installed and used in accordance with all applicable national, state, and local building/fire/electrical codes. Additionally, in the USA, installations must comply with the National Electrical Code (NFPA 70), NFPA 30, and the Automotive and Marine Service Station Code (NFPA 30A) codes and regulations. Canadian installations must comply with the Canadian Electrical Code.
- All peripheral equipment connected to the RS-232 ports must be listed, have an Electronics Industrial Association (EIA) standard RS-232 communications protocol and not be installed over a hazardous location.
- Power for the data terminal and external modem must come from a separate circuit breaker rated at no less than 10A.
- All conduits must be made of metal to provide the necessary shielding.
- Use the Conduit Size Chart to determine the proper conduit size.
- RS-232 communication must not exceed 100 feet. RS-232 communication wires must be in a separate metal conduit away from AC wires.
- For communication distances exceeding 100 feet, you must use a Gasboy RS-422 Short Haul Modem.
- It is recommended that high voltage AC power wires be installed in a separate conduit, away from the low voltage DC signal wires. However, if AC and DC wires share the conduit, communication wiring must use the cable specified in “[RS-422 - SHMs](#)” on [page 22](#).
- DC RS-422 communication wires can be combined in the same conduit.
- When using the master/satellite configuration, the maximum field wiring cable length between the first and last unit must not exceed 1500 feet (455 m). It is recommended that high voltage AC wires be installed in a separate conduit, away from the low voltage DC signal wires. However, if AC and DC wires share the conduit, communication wiring must use the cable specified in “[Communication Requirements](#)” on [page 19](#).

Conduit Requirements

All wiring (AC and DC) connecting different components of the Gasboy FMS must be installed in threaded, rigid, metal conduit except as noted in “[Communication Requirements](#)” on [page 19](#) and “[RS-422 - SHMs](#)” on [page 22](#). PVC IS NOT ACCEPTABLE. Components of the system include pumps, dispensers, submersible pumps, submersible starter relays, circuit breaker panels, optional wall-mount PCUs and the TopKAT system. Communications equipment signal wires must also be run in the metal conduit, except for RS-422 wiring, as noted in “[Communication Requirements](#)” on [page 19](#).

Communication equipment signal wires must also be run in metal conduits. High-voltage (AC) and low-voltage (DC) must not be combined in a common conduit, Junction box, or wire trough unless the cable is used as specified in “[Communication Requirements](#)” on [page 19](#).

All conduits must be connected to the TopKAT pedestal through the holes and knockouts provided by the factory. Do not make any other holes in this unit. If you must make holes at locations other than those provided, contact Gasboy for approval.

All wiring and conduit runs must conform to all building/fire codes, all Federal, State, and Local codes, the National Electrical Code (NFPA 70), NFPA 30, and the Automotive and Marine Service Stations Code (NFPA 30A). Canadian users must also comply with the Canadian Electrical Code.

Use the tables below as a guideline to determine the proper conduit sizes for the Gasboy TopKAT FMS. When planning the orientation of wiring runs, follow the applicable Gasboy wiring diagram and consider the layout of components at the site. Long runs or a large number of bends may require you to increase the conduit size over what is listed here.

To determine the conduit size required, use the “[THHN/THWN Wire Areas](#)” table to find the area for each wire gauge. Add up all wire areas. Use the “[Areas of Trade Size Conduit](#)” table to select the smallest number in the 25% fill area (based on NEC 501-1) that comes closest without exceeding the total wire area.

THHN/THWN Wire Areas

Gauge	Diameter		Area (square units)	
	Inches	Millimeters	Inches	Millimeters
18	.090	2.29	.007	4.1
16	.104	2.64	.009	5.5
14	.118	2.95	.011	6.8
12	.135	3.43	.014	9.2
10	.169	4.29	.022	14.5
8	.216	5.49	.037	23.7
6	.259	6.60	.053	34.2
4	.331	8.41	.086	55.5
3	.359	9.14	.102	65.6
2	.394	10.01	.122	78.7
1063A	.417	10.59	.137	88.4

Areas of Trade Size Conduit

Trade Size	Internal Diameter		Area (square units)		Fill Area (square units) 25% fill	
	Inches	Millimeters	Inches	Millimeters	Inches	Millimeters
1/2	.629	16	.303	196	.076	49
3/4	.826	21	.532	343	.133	86
1	1.063	27	.862	556	.215	139
1-1/4	1.378	35	1.50	968	.375	242
1-1/2	1.614	41	2.04	1314	.509	329
2	2.087	53	3.36	2165	.839	541

Power Requirements

AC Power to the TopKAT System

When mounted to a 9800 or ASTRA, AC power for the TopKAT system is supplied from the same power source used to power the 9800 or ASTRA Micro Feed. A wiring cable for AC power from the 9800 or ASTRA to the TopKAT is supplied with the TopKAT. Refer to [“ASTRA to TopKAT Cabling”](#) on [page 27](#) for more information.

When mounted on a pedestal, AC power for the TopKAT system must come from a separate, dedicated circuit breaker. No other equipment, including the system's pumps or dispensers, may be powered from this breaker.

When the TopKAT system is pedestal-mounted with internal PCUs, AC power for the TopKAT system must be supplied from the same power source used to power the PCUs. A wiring cable for AC power from the TopKAT system to the PCUs is supplied. When the TopKAT system is pedestal-mounted but is being used with wall-mounted PCUs, the AC power for the TopKAT system and PCUs must come from a separate, dedicated circuit breaker. No other equipment, including the system's pumps and dispensers may be powered from this breaker.

TopKAT Peripheral Equipment

When used with a 9800 or ASTRA, AC power for the data terminal or external modem must come from a separate, dedicated circuit breaker. No other equipment, including the system's pump or remote dispenser control may be powered from this breaker. However, for 9800 and ASTRA applications, it is acceptable to power the data terminal or external modem from the breaker that supplies power to the electronic register (Micro Feed on 9800 or ASTRA). This breaker is the same one that supplies power to the TopKAT system. Whenever possible, one breaker should be used to supply the Micro Feed and the data terminal or external modem. However, it is acceptable to supply power to both from multiple breakers within the same breaker panel and the same phase of power. When necessary, power for the data terminal or modem may be supplied from a separate, dedicated breaker located in a different breaker panel.

When used with a pedestal TopKAT system, power for a data terminal or external modem can come from the same breaker as the TopKAT system.

The system requires 115 VAC + 10% 47-63 Hz, or optional 230 VAC + 10% 47-63 Hz of power. The system draws a maximum of 95 Watts.

Grounding

Proper system grounding is an extremely important part of system installation. As with the AC power, the grounds for all system components should return to the same breaker panel. This helps you to assure a common ground throughout the system, which is necessary for protection of the RS-485 data loop circuitry. Grounds for all system devices should be wired to the breaker panel ground bus bar, which in turn should be grounded to a ground rod. A conduit ground does not provide sufficient ground. It is recommended that the neutral and ground bus bars be bonded together when it is not prohibited by local codes.

Suction Pumps

The TopKAT system, with Mechanical Interface or Mechanical PCU options, is capable of directly driving pump motors up to 3/4 HP at 115 VAC or 1-1/2 HP at 230 VAC. A starter relay must be used with pump motors that exceed this limitation. A separate circuit breaker should be supplied for each pump to meet the current requirements and to allow isolated control with the circuit breaker panel in case of problems.

Dispensers

The TopKAT system with the Mechanical Interface option is capable of directly driving submersible pumps up to 3/4 HP at 115 VAC or 1-1/2 HP at 230 VAC. A dispenser with a submersible pump exceeding this limitation requires the use of a submersible starter relay. A separate circuit breaker should be supplied for each dispenser in cases where it will directly drive the submersible pump. Dispensers may be grouped together on a single breaker when the submersible pump has its own breaker. It is recommended that no more than two dispensers be powered from one breaker to maintain isolated control with the circuit breaker panel in case of problems.

Wire Size

A wiring cable for AC power from the 9800 or ASTRA to the TopKAT system is supplied with the TopKAT system. If you are wiring a pedestal TopKAT system or wall-mount Mechanical PCUs, the AC power wire size must be 14 AWG or larger for runs of up to 300 feet from the breaker panel to the system. Sites with distances over 300 feet must use 12 AWG wire or larger.

The AC wire size for power of the system data terminal or external modem must be 14 AWG or larger. This gauge of wire will be sufficient for runs of up to 300 feet (91m) from the breaker panel to the system. Components with distances over 300 feet (91m) must use 12 AWG wire or larger. All wires should be stranded.

The specifications for the communication wire/cable size can be found in RS-485 “Communication Requirements” on [page 19](#) and/or “RS-422 - SHMs” on [page 22](#) in this chapter.

Mechanical Interface Option

The AC wire size for a suction pump is dependent on the HP rating of the pump motor, the voltage at which the pump will be operated (115/230), and the distance from the circuit breaker panel to the pump. The chart below may be used as a guide to select the proper size wire according to the specific installation requirements. The wire size for the Reset Complete from the pump should be 14 AWG. All wires should be stranded.

The AC wire size for the control lines of a dispenser should be 12 AWG. These control lines supply power for the reset mechanism, solenoid valve, and submersible starter relay (when the submersible pump is not directly powered by the dispenser). The wire size for the submersible pump power depends on the HP rating of the pump motor, the voltage at which it will be operated (115/230), and the distance from the circuit breaker to the pump. Use the following table as a guide to select the proper wire size according to specific installation requirements. The wire size for the Reset Complete from the dispenser should be 14 AWG. All wires should be stranded.

The DC wire size for the pulser must be 18 AWG (when they are used). Shielded cables, as described in “[Pulser Wiring Notes](#)” on [page 50](#) allows pulser lines to run with AC wires.

The DC wire size for RS-422 lines should be 18 AWG and meet the specifications outlined in “[Communication Requirements](#)” on [page 19](#).

Refer to “[Communication Requirements](#)” on [page 19](#) to determine the wire size and type for communication wiring of your specific application.

115 Volt Wire Gauge Sizes per Feet/Meters of Run (Note)

	25'	50'	100'	150'	200'	250'	300'
Motor H.P.	7.6M	15.2M	30.5M	45.7M	61M	76.2M	91.4M
1/2	14	12	10	8	8	8	8
3/4	14	12	10	8	8	6	4

Note: For runs over 300 feet, use the relay at the motor location.

230 Volt Wire Gauge Sizes per Feet/Meters of Run (Note)

	25'	50'	100'	150'	200'	250'	300'
Motor H.P.	7.6M	15.2M	30.5M	45.7M	61M	76.2M	91.4M
1/2	14	12	12	12	10	10	10
3/4	14	12	12	10	10	10	8
1-1/2	12	12	10	10	8	8	8

Note: For runs over 300 feet, use relays at the motor location.

Communication Requirements

The TopKAT system utilizes RS-485, RS-232, and RS-422 modes of communication for communicating to the ASTRA, 9800, Mechanical PCUs and peripheral equipment. The TopKAT has three ports:

- Port 1 is an RS-485 port that is dedicated to communicate with the ASTRA or satellite TopKAT system.
- Ports 2 and 3 are configurable for either an RS-232 or RS-422 for communication with a data terminal, modem, or PC.

Phone line (modem) communication may also be used when remote communication to the site is desired. If a TopKAT internal modem is used, Port 3 is not available for external communication wiring. The specific requirements for each of these modes of communication are listed below.

RS-485 - ASTRA and Mechanical PCUs

RS-485 wiring is used for communication between the TopKAT system, ASTRA, and Mechanical PCUs. This communication takes place over the RS-485 wiring that is supplied with the TopKAT when the TopKAT system is mounted on an ASTRA or the Mechanical PCU is mounted in the TopKAT pedestal.

RS-485 - Master/Satellite Option

The master/satellite option uses four wires to operate a full-duplex RS-485 communication loop. Ports 2 and 3 of the master can be set for either RS-232 or RS-422 communications to a data terminal or computer or used to communicate with an optional built-in modem.

- All wiring is to be installed and used in accordance with all building/fire codes, Federal, State and Local codes, National Electrical Code (NFPA 70), NFPA 30, and Automotive and Marine Service Station Code (NFPA 30A) codes and regulations. Wiring must also conform to the wiring diagram supplied with the pump/remote dispenser. Canadian users must comply with the Canadian Electrical Code.
- **Power:** The AC power for the short haul modem should come from the same breaker that supplies the peripheral device or the system (Micro Feed).
- **Cable:** A twisted-pair shielded cable is highly recommended for RS-485 wiring. Although it is recommended that wires be run in a conduit away from AC wires, they can be combined in the same conduit with AC wires, provided that a UL-listed cable with the following specifications is used:
 - Conductor: 18 AWG stranded wire; one twisted-pair
 - Shield: Foil-wrapped 100% coverage and/or tinned copper braid 90% coverage
 - Drain Wire: Stranded, tinned copper, 20 AWG or larger/or braided shield
 - Voltage Rating: Maximum operating voltage of 600 V
 - Environmental: Gas and oil-resistant; suitable for wet or dry locations.

Gasboy can supply Belden® 1120A (part number C09672) that is a UL-listed, 2-conductor cable that meets the requirements listed above.
Belden 1120A is UL-listed but not CSA-listed.

Cables with a voltage rating of less than 600 V must be installed in a conduit away from all AC wires.

- **Conduit:** When you use the recommended shielded twisted-pair cable, RS-485 wires can be run with AC wires in the metal conduit. The shield drain wire must be connected to the system AC ground. Only AC wires for the system and pumps can be installed in the AC conduit. Do not run the cable outdoors without the use of metal conduit. Do not run this cable overhead when outdoors.

The cable can be run indoors without the use of a metal conduit. The shield drain wire must be connected to the system AC ground (at one end only).

If you use cables other than the ones that are recommended above, the RS-485 field wires must be installed in a metal conduit away from AC wires.

- **Distance:** The maximum overall field wiring cable length between all units must not exceed 1500 feet (455 m).

RS-485 - Standalone TopKAT System or Wall-Mount PCU

When the TopKAT system must communicate to a 9800 or wall-mount PCU through Port 1 (RS-485) of the TopKAT system and the TopKAT is not directly mounted on the 9800, the appropriate interconnect cable must be used. It must always be used in this configuration. A distance of up to 1500 feet (455 m) is allowed. Refer to [“Port Communication Wiring”](#) on [page 28](#) for the wiring diagrams.

Installation Requirements

- **Internationally and domestically:** All wiring is to be installed and used in accordance with all applicable national, state and local building/fire/electrical codes. Additionally, in the USA, installations must comply with the National Electrical Code (NFPA 70), NFPA 30, and the Automotive and Marine Service Station Code (NFPA 30A) codes and regulations. Canadian installations must comply with the Canadian Electrical Code.
- **Cable:** A twisted-pair shielded cable is highly recommended for RS-485 wiring. Although it is recommended that wires be run in a conduit away from AC wires, they can be combined in the same conduit with AC wires, provided that a UL-listed cable with the following specifications is used:
 - Conductor: 18 AWG stranded wire; one twisted-pair
 - Shield: Foil-wrapped 100% coverage and/or tinned copper braid 90% coverage
 - Drain Wire: Stranded, tinned copper, 20 AWG or larger/or braided shield
 - Voltage Rating: Maximum operating voltage of 600 V
 - Environmental: Gas and oil-resistant; suitable for wet or dry locations.

Gasboy can supply Belden 1120A (part number C09672) which is a UL-listed, 2-conductor cable that meets the requirements listed above.

Note: Belden 1120A is UL-listed but not CSA-listed.

Cables with a voltage rating of less than 600 V must be installed in a conduit away from all AC wires.

- **Conduit:** When you use the recommended shielded twisted-pair cable described previously, RS-485 wires can be run with AC wires in a metal conduit. The shield drain wire must be connected to the system AC ground. Only AC wires for the system and pumps can be installed in the AC conduit. Do not run the cable outdoors without the use of a metal conduit. Do not run this cable overhead when outdoors.

The cable can be run indoors without the use of a metal conduit. The shield drain wire must be connected to the system AC ground (at one end only).

If you are using a cable other than what was recommended previously, the RS-485 field wires must be installed in a metal conduit away from AC wires.

- **Distance:** The maximum field wiring cable length must not exceed 1500 feet (455 m).

RS-232

RS-232 wiring can be used for communication between the TopKAT system and EIA RS-232 compatible peripheral devices (CRT/printer, modem, and so on). The remote end of the wiring can be terminated with either an RS-232D connector or a Gasboy termination box. You must follow these installation requirements when installing the RS-232 communication lines:

- All peripheral equipment connected to the RS-232 ports must be UL-listed, have an EIA standard RS-232 communication protocol and not be installed over a hazardous location.
- **Distance:** The following distances must be adhered to when installing the RS-232 communication lines:
 - 1 - 100 feet (1 - 31 meters): RS-232 can be directly connected to a peripheral device.
 - 101 - 1500 feet (32 - 455 meters): RS-422 and Gasboy Short Haul Modem (SHM) are required. Refer to “RS-422 - SHMs” on page 22 for details.
- **Conduit:** All direct connect RS-232 cables over 15 feet (5 m) must be in a metal conduit away from any AC wires. For conduit requirements of SHMs, Refer to the installation sheet that applies to the device being used.
- **Cables:** RS-232 cables can either be purchased from Gasboy or made by the installer. The type of cable needed will vary according to the device it connects. When making cables, the wire used must be stranded and not a solid core.

Figure 4-1: RS-232 1:1 Cable (Part Number C04549: 8 feet M/M)

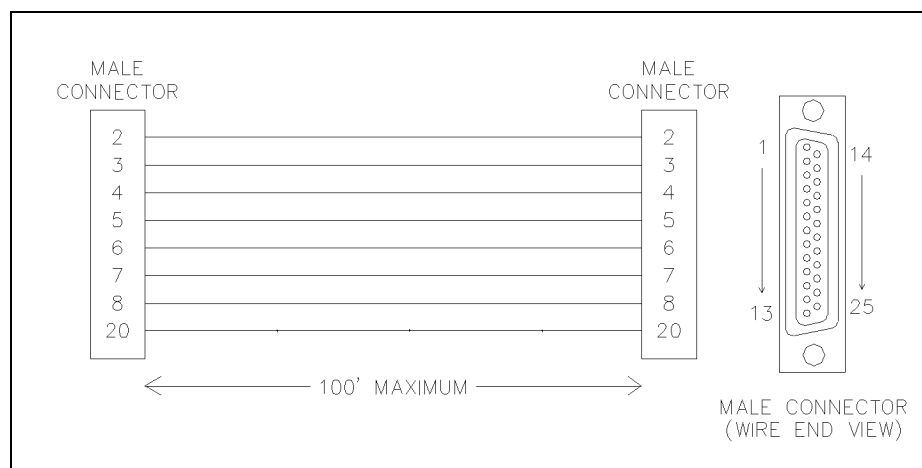
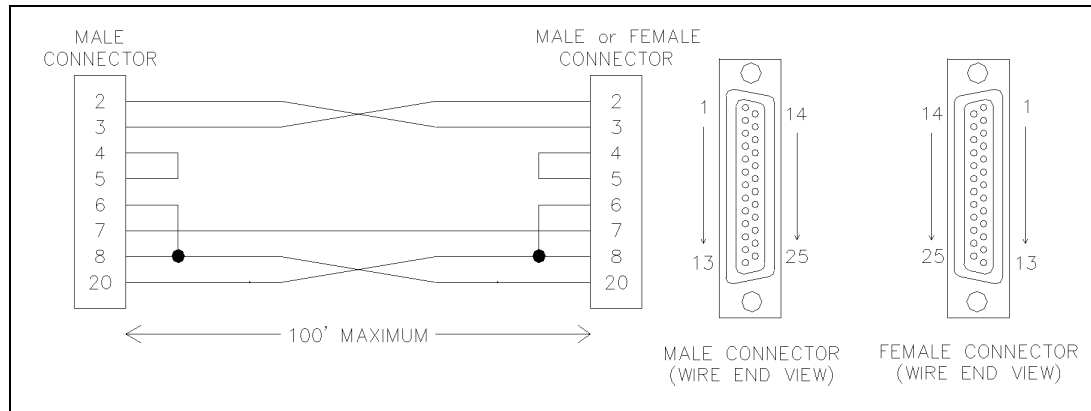

Figure 4-2: DTE Cross Cable (Part Number C05039: 8 feet M/M, Part Number C05928: 8 feet M/F)



RS-232 - Termination Box

A termination box can be purchased from Gasboy. Gasboy provides the installer with an easy-to-wire terminal block connected to the proper pins on an RS-232D female connector. The terminal block will accept up to 18 AWG wire.

RS-422 - SHMs

A Gasboy SHM and the appropriate interconnect cable must be used when the RS-422 communication mode is being used to communicate to the ports of the TopKAT system. It must be used for distances between 100 and 1500 feet (31 and 455 meters). It can be used for distances under 100 feet in place of RS-232 wiring. One SHM is required at the remote end of the communication wiring. Refer to [“Port Communication Wiring”](#) on [page 28](#) for wiring diagrams.

Installation Requirements

- **Internationally and domestically:** All wiring is to be installed and used in accordance with all applicable national, state and local building/fire/electrical codes. Additionally, in the USA, installations must comply with the National Electrical Code (NFPA 70), NFPA 30, and the Automotive and Marine Service Station Code (NFPA 30A) codes and regulations. Canadian installations must comply with the Canadian Electrical Code.
- **Power:** The AC power for the SHM must come from the same breaker that supplies the peripheral device or the system (micro feed).
- **Cable:** A twisted-pair shielded cable is highly recommended for RS-422 wiring. Although it is recommended that wires be run in a conduit away from AC wires, they can be combined in the same conduit with AC wires, provided a UL-listed cable with the following specifications is used:
 - Conductor: 18 AWG stranded wire; two twisted-pairs
 - Shield: Foil-wrapped 100% coverage and/or tinned copper braid 90% coverage
 - Drain Wire: Stranded, tinned copper, 20 AWG or larger/or braided shield
 - Voltage Rating: Maximum operating voltage of 600 V
 - Environmental: Gas and oil-resistant; suitable for wet or dry locations

Gasboy can supply Belden 1063A (Part Number C09655) which is a UL-listed, 4-conductor cable that meets the requirements listed above.

Note: Belden 1063A is UL-listed but not CSA-listed.

Cable with a voltage rating of less than 600 V must be installed in a separate conduit away from all AC wires.

These modems must be connected with private lines and will not work if connected into a telephone network.

- **Conduit:** When you use the recommended shielded twisted-pair cable described previously, RS-422 wires can be run with AC wires in a metal conduit. The shield drain wire must be connected to the system AC ground. Only AC wires for the system and pumps can be installed in the AC conduit. Do not run the cable outdoors without the use of metal conduit. Do not run this cable overhead when outdoors.
- The cable can be run indoors without the use of a metal conduit. The shield drain wire must be connected to the system AC ground (at one end only).
- If you use a cable other than what was recommended previously, the RS-422 field wires must be installed in a metal conduit away from any AC wires.
- **Distance:** The maximum field wiring cable length must not exceed 1500 feet (455 m).

Terminal Block ID

All communication wiring to the TopKAT system is terminated to green wiring connectors on the communication board or the electronic housing assembly.

To gain access to the inside of the TopKAT system, proceed as follows:

- 1 Unlock the rear door and open it completely.
- 2 Unscrew the two captive screws, while holding the hood in place.
- 3 Slide the hood towards the rear of the unit (about 1 inch) and lift it straight up.

The left side of the electronic housing assembly is shown in [Figure 4-3](#).

Figure 4-3: Electronic Housing Assembly - Left Side

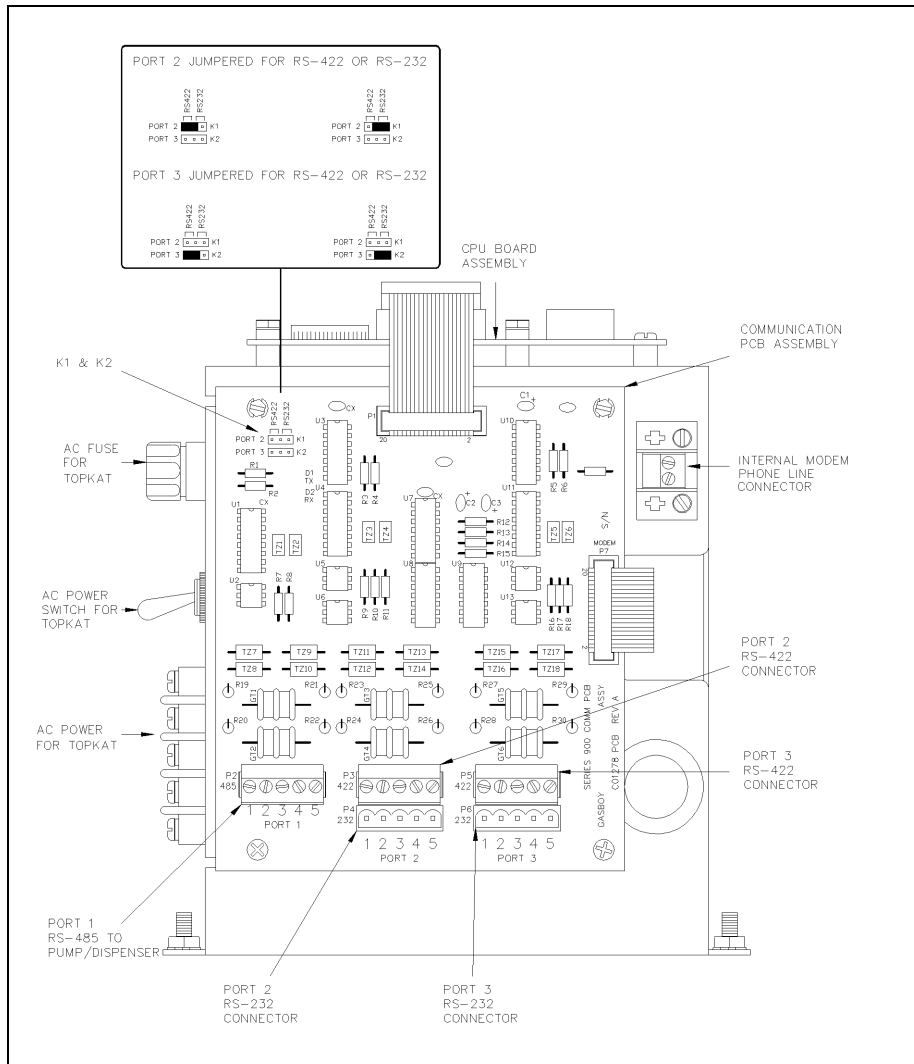

5 – Series 9820 ASTRA Installation

Description

The Gasboy TopKAT system mounted on top of the ASTRA pedestal controls the dispenser activation. The TopKAT system communicates with the ASTRA through the first of its three asynchronous ports. Port 1 is a dedicated RS-485 communication loop that allows the TopKAT system to control all functions of the ASTRA. Ports 2 and 3 can be set for either RS-232 or RS-422 communications to a data terminal or computer. Refer to “[Communication Requirements](#)” on [page 19](#) for wiring considerations.

Figure 5-1: ASTRA Dimensions

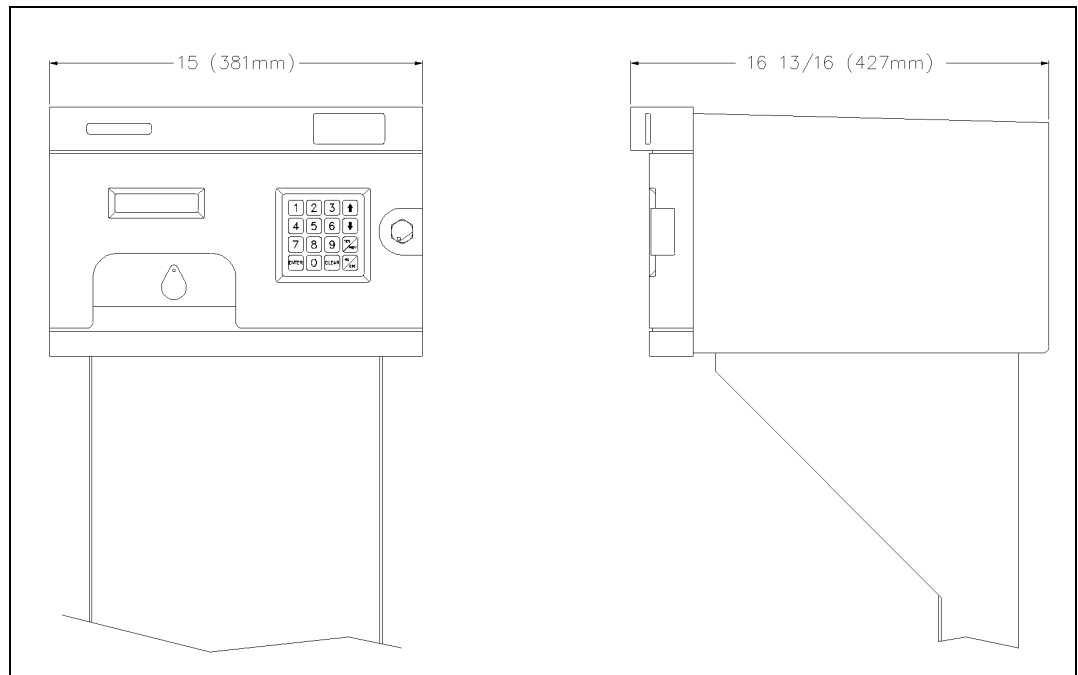
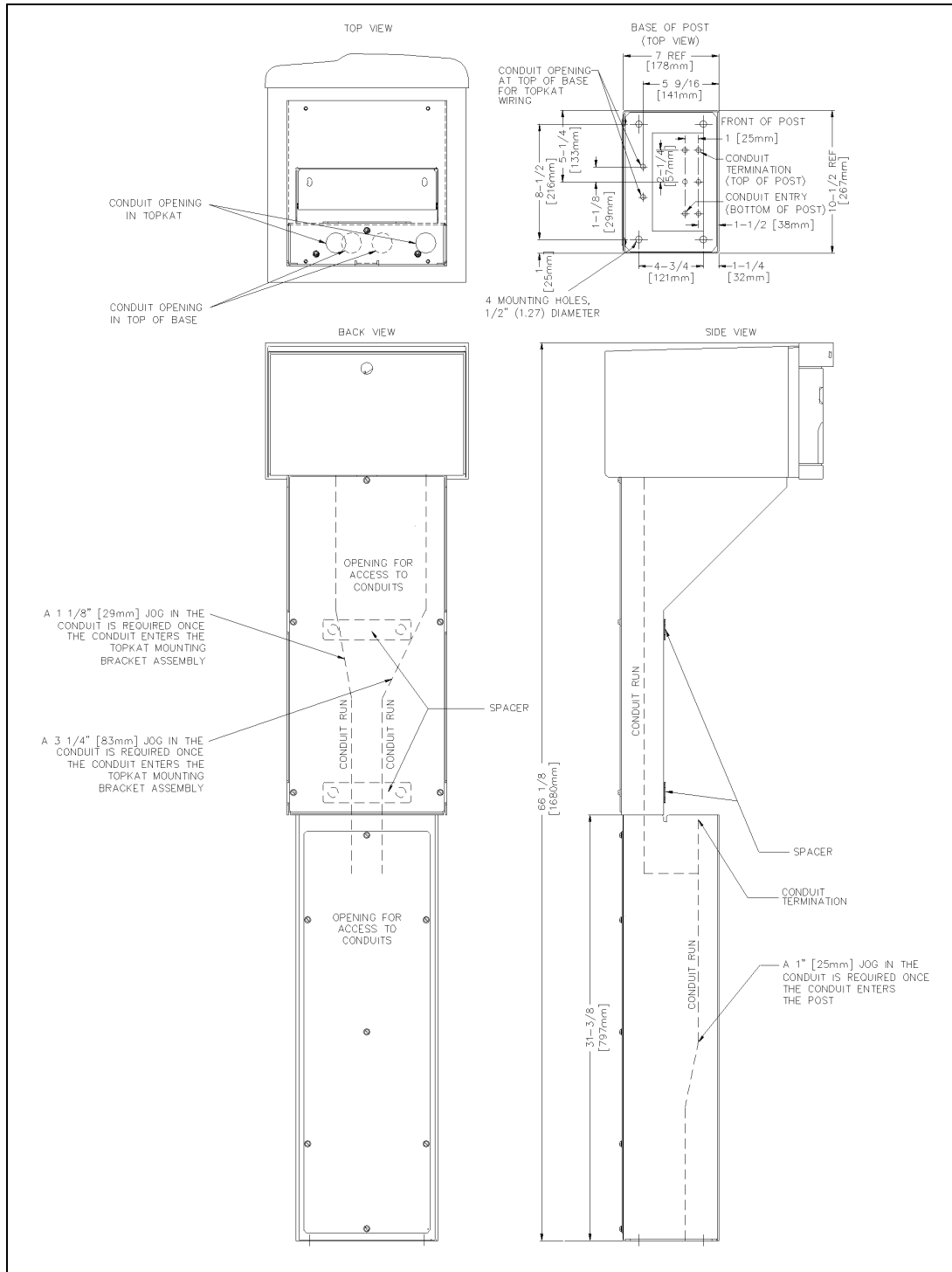

Figure 5-2: 011889 Base Layout (Optional Post with TopKAT) - Models 9822 and 9823



ASTRA to TopKAT Cabling

The interconnection of the ASTRA to the TopKAT system requires two cables:

- RS-485 communication cable
- AC power cable

Both the cables are supplied by Gasboy.

Figure 5-3: RS-485 Communication Cable

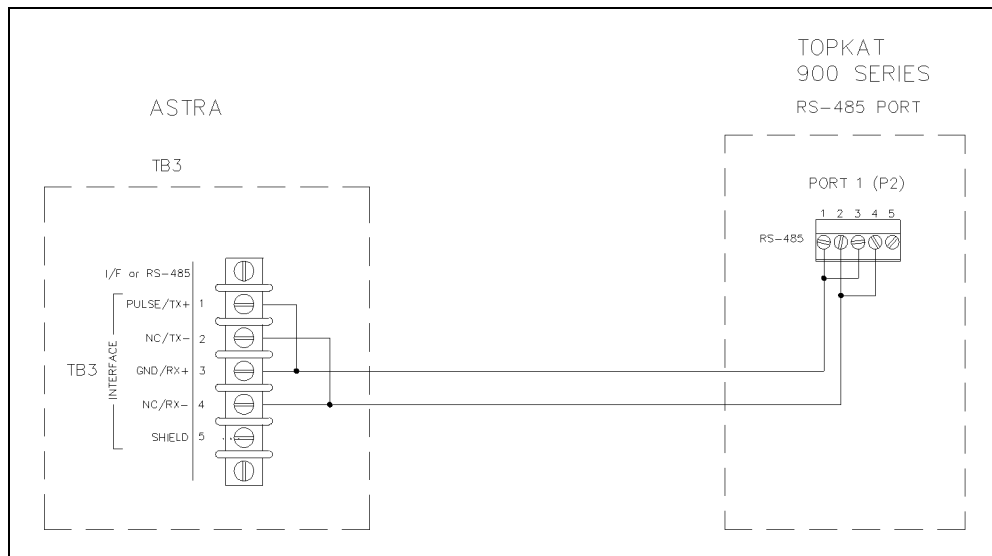
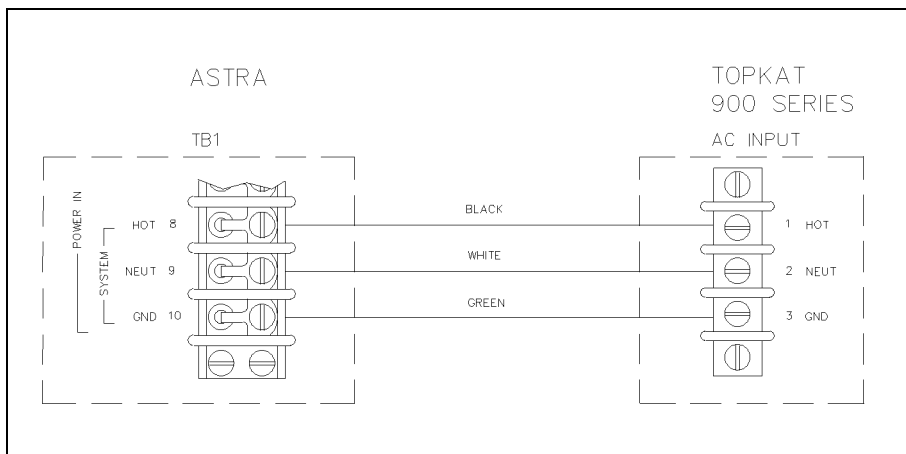

Figure 5-4: ASTRA to TopKAT AC Power Cable



For ASTRA switch settings, access, and location, refer to [“Appendix B: Atlas CPU Board Jumper Settings”](#) on [page B-1](#) and MDE-4652 Atlas™ 9800 Electronics Field Installation Instructions.

Port Communication Wiring

The following illustrations show the pin-to-pin layout of the possible wiring schemes for the TopKAT ports. Each port may be wired for any of the wiring schemes, provided the installation requirements are met as outlined in [“Communication Requirements”](#) on [page 19](#).

Figure 5-5: RS-232 - D Connector

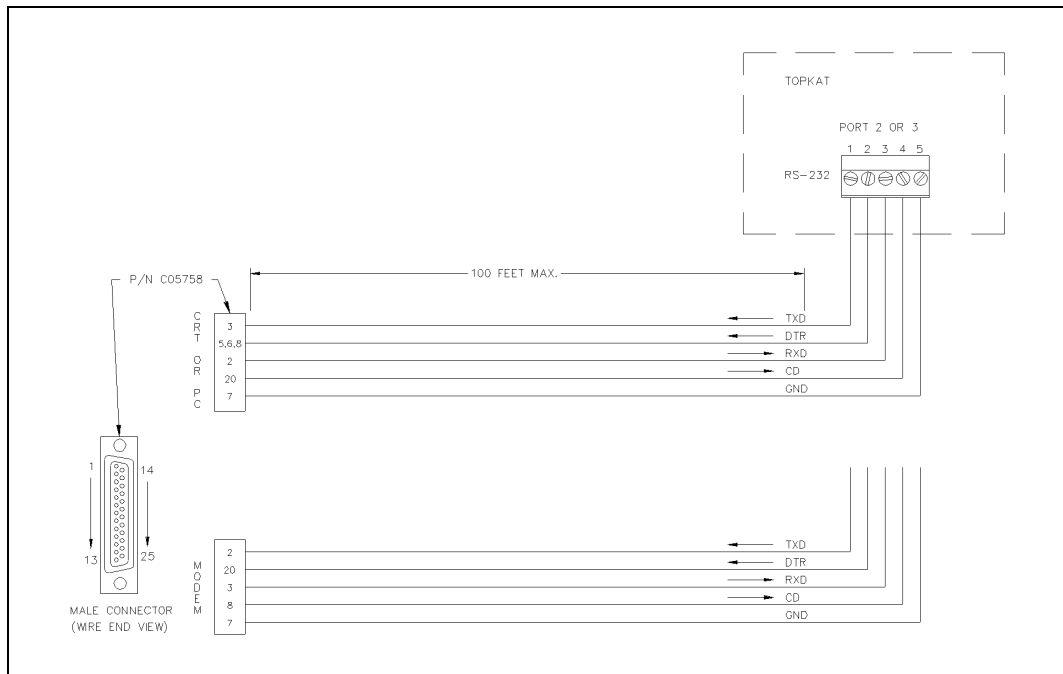

Note: In the TopKAT system, the green connector must be connected to P4 on the communication board for Port 2, and P6 for Port 3. The K1 and K2 jumper for the port being used should be set to RS-232. Refer to [“Terminal Block ID”](#) on [page 24](#) for the location of K1 and K2 jumpers.

Figure 5-6: RS-232 - Gasboy Termination Box

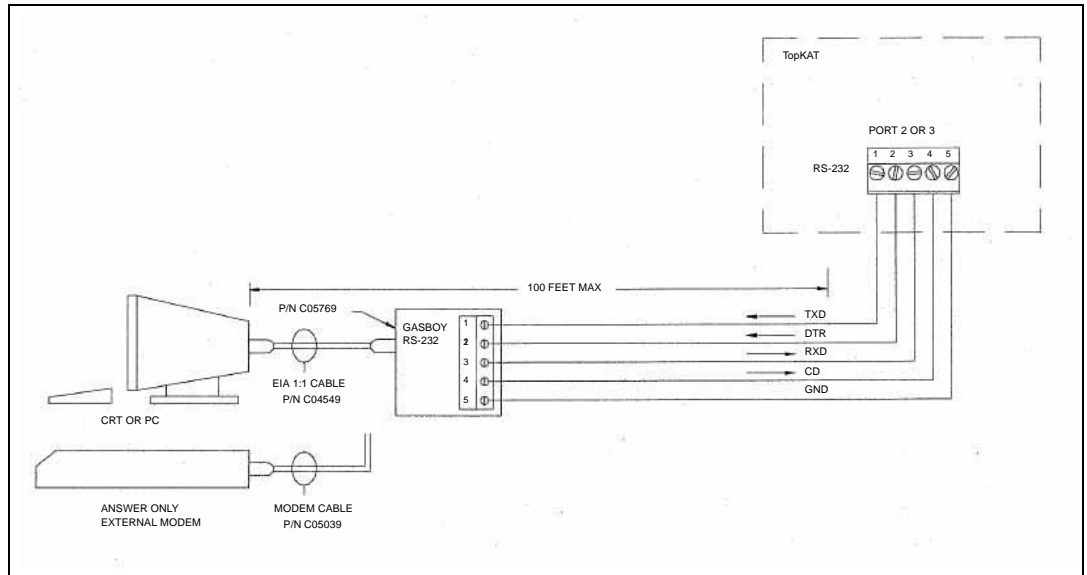

Note: In the TopKAT system, the green connector must be connected to P4 on the communication board for Port 2, and P6 for Port 3. The K1 and K2 jumper for the port being used should be set to RS-232. Refer to “Terminal Block ID” on page 24 for the location of K1 and K2 jumpers.

Figure 5-7: RS-422 - Gasboy Short Haul Modem

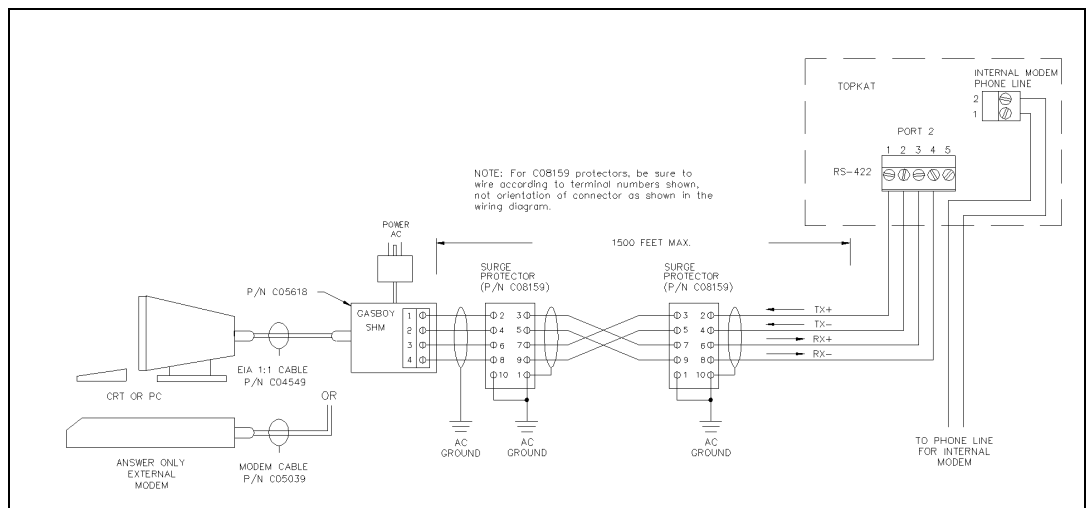

Notes: 1) In the TopKAT system, the green connector must be connected to P3 on the communication board for Port 2 and P5 for Port 3.

2) If a TopKAT internal modem is used, Port 3 is not available for external communication wiring.

3) The K1 and K2 jumper for the port being used should be set to RS-422. Refer to “Terminal Block ID” on page 24 for the location of K1 and K2 jumpers.

Figure 5-8: Internal Modem

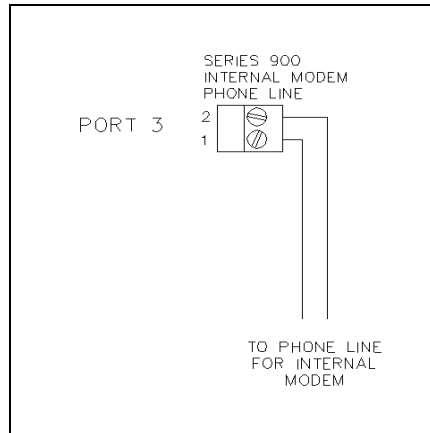

Notes: 1) If a TopKAT internal modem is used, Port 3 is not available for external communication wiring.

2) The K2 jumper for Port 3 should be removed. Refer to [“Terminal Block ID”](#) on page 24 for the location of the K2 Jumper.

TopKAT Master/Satellite Communications Wiring

Figure 5-9: Two TopKATs, Three ASTRA Pumps, with Short Haul Modem Wiring

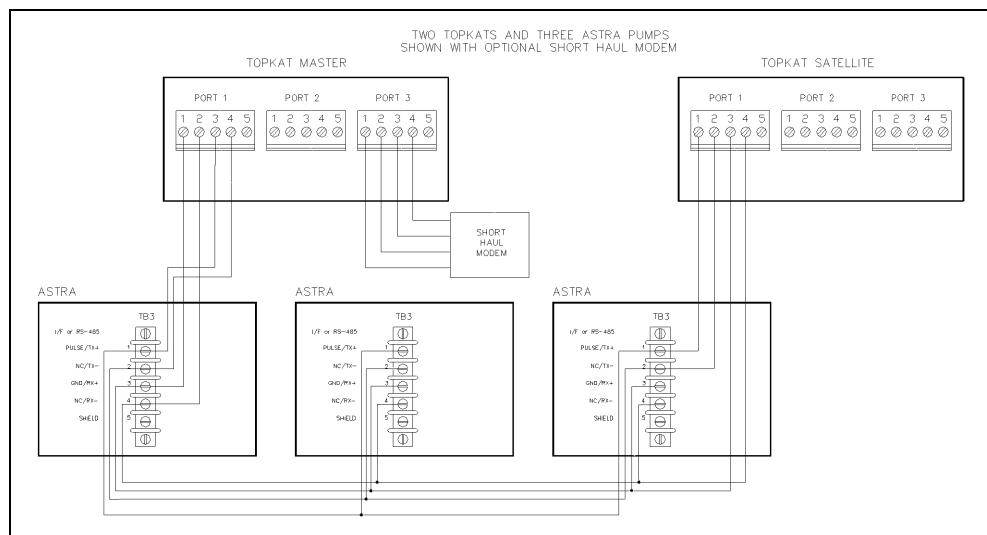

Wiring for a CRT Terminal and Okidata Printer

Figure 5-10 shows the connections between the TopKAT port and the CRT terminal and Okidata® printer.

Figure 5-10: TopKAT Port to CRT to Okidata Printer Connections

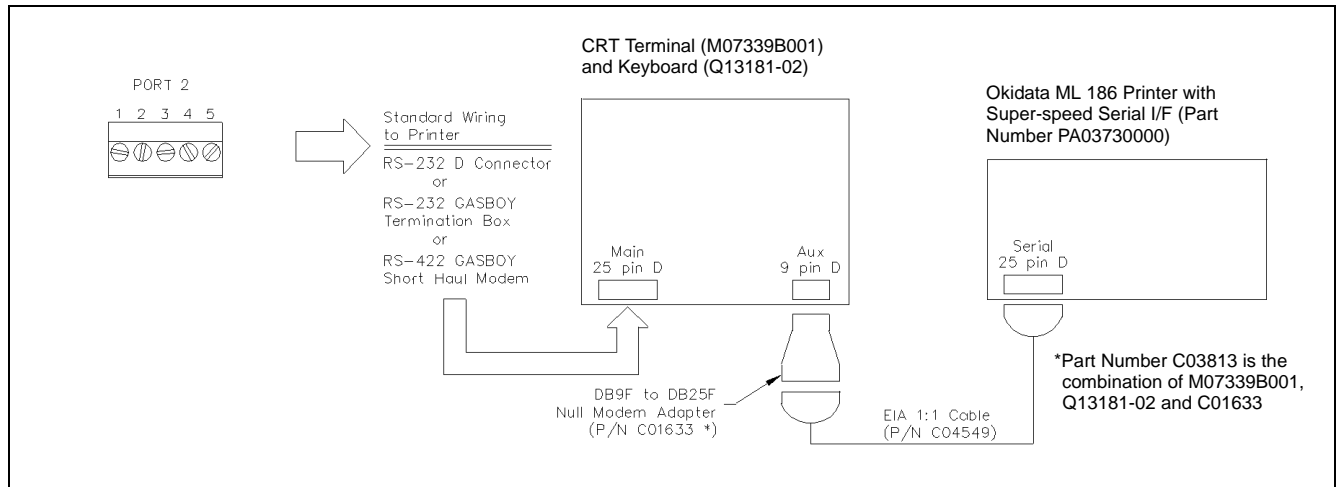

Wiring for Modems

External Modems

The type of phone line required for communication via an external modem is dependent on the type of modem used and the method of communication desired. Consult the manual that comes with the modem for specific requirements.

Internal Modem

When the TopKAT internal modem is installed, Port 3 communication is routed through the modem in place of being wired at the DC Junction box. Jumper K2 should be removed. Refer to “Terminal Block ID” on page 24 for the location of the K1 and K2 jumpers. The phone line for the internal modem can be installed in the DC conduit. If you install the modem in the DC conduit, a two twisted-pair shielded cable must be used as specified in “Communication Requirements” on page 19 and the shield drain wire must be connected to the system AC ground. Check with your local phone company for proper installation of the phone line.

This page is intentionally left blank.

6 – TopKAT Master/Satellite

Description

The TopKAT master/satellite option allows up to eight TopKAT units to be linked together through a full-duplex RS-485 data loop, with one acting as the master controlling unit. The master is the only unit that will need to have a data communication link as it will collect all transactions and maintain the complete database for the entire site. The data communication ports of the satellite units are disabled. The individual TopKAT units may use the standard RS-485 loop (9800 pumps) to communicate to their pumps or the mechanical interface. The interface must be the same for each pump within an individual TopKAT system. However, both types of pump interfaces may be combined within a master/satellite configuration.

Note: Full-duplex communication requires four wires and is not presently supported in the 9850, as it does not have the necessary communication wires.

There are four possible configurations for the master/satellite:

- All electronic, where the TopKAT system can control up to eight electronic 9800/ASTRAs and up to seven satellite readers
- All mechanical, where the master TopKAT system controls up to two mechanical hoses and up to 14 other hoses (two hoses each for up to seven TopKATs)
- Combination, where the master TopKAT system controls two electronic 9800/ASTRAs and up to 14 mechanical hoses (two hoses each for up to seven TopKATs)
- Mechanical pumps, where the master TopKAT system can control up to eight mechanical pumps (four hoses per Mechanical PCU, up to two Mechanical PCUs) and up to seven satellite readers.

Figure 6-1: Wiring Diagram: TopKAT Master/Satellite Communications Wiring - 9820

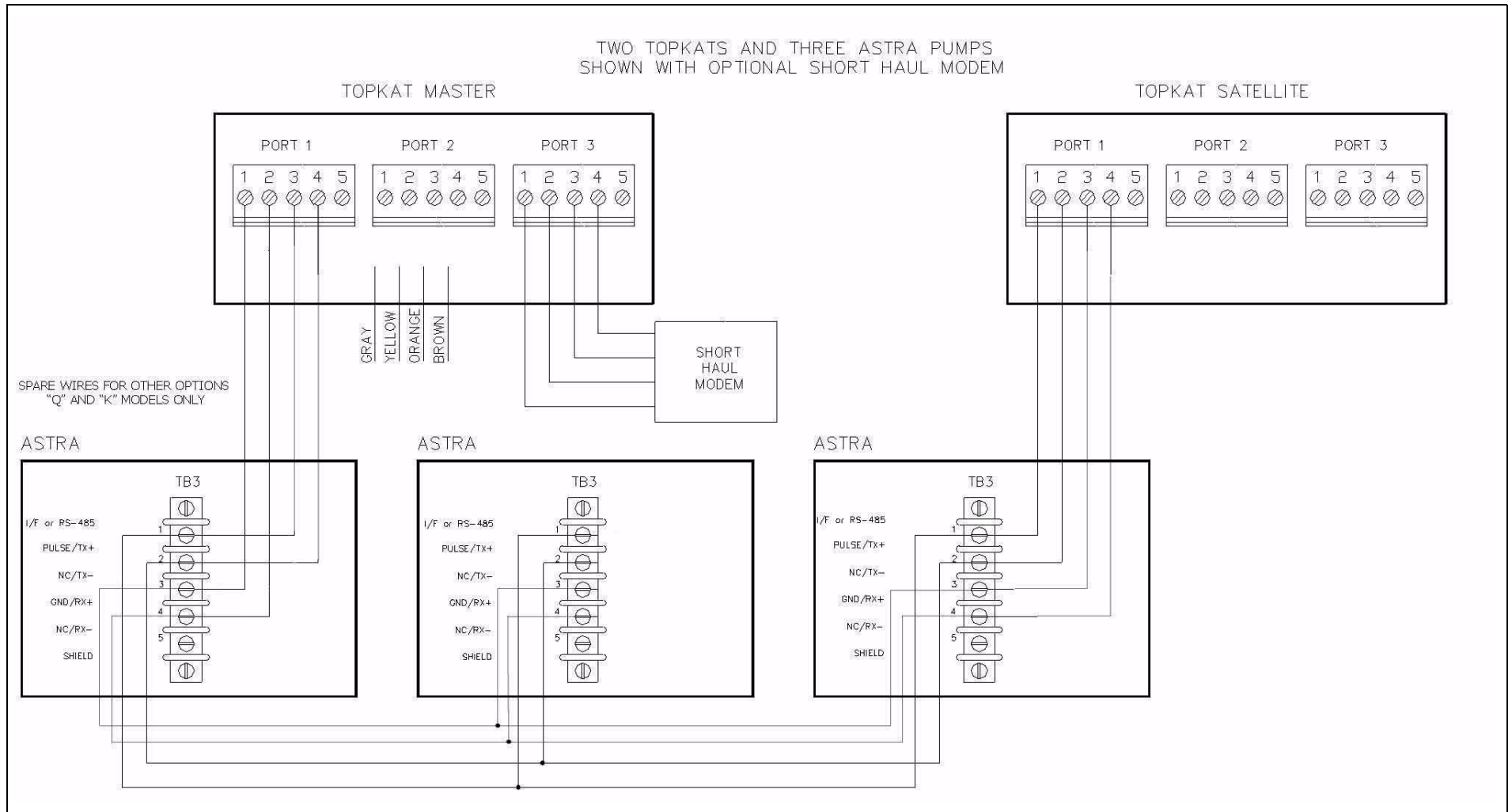

Figure 6-2: Wiring Diagram: TopKAT Master/Satellite Communications Wiring - 9800

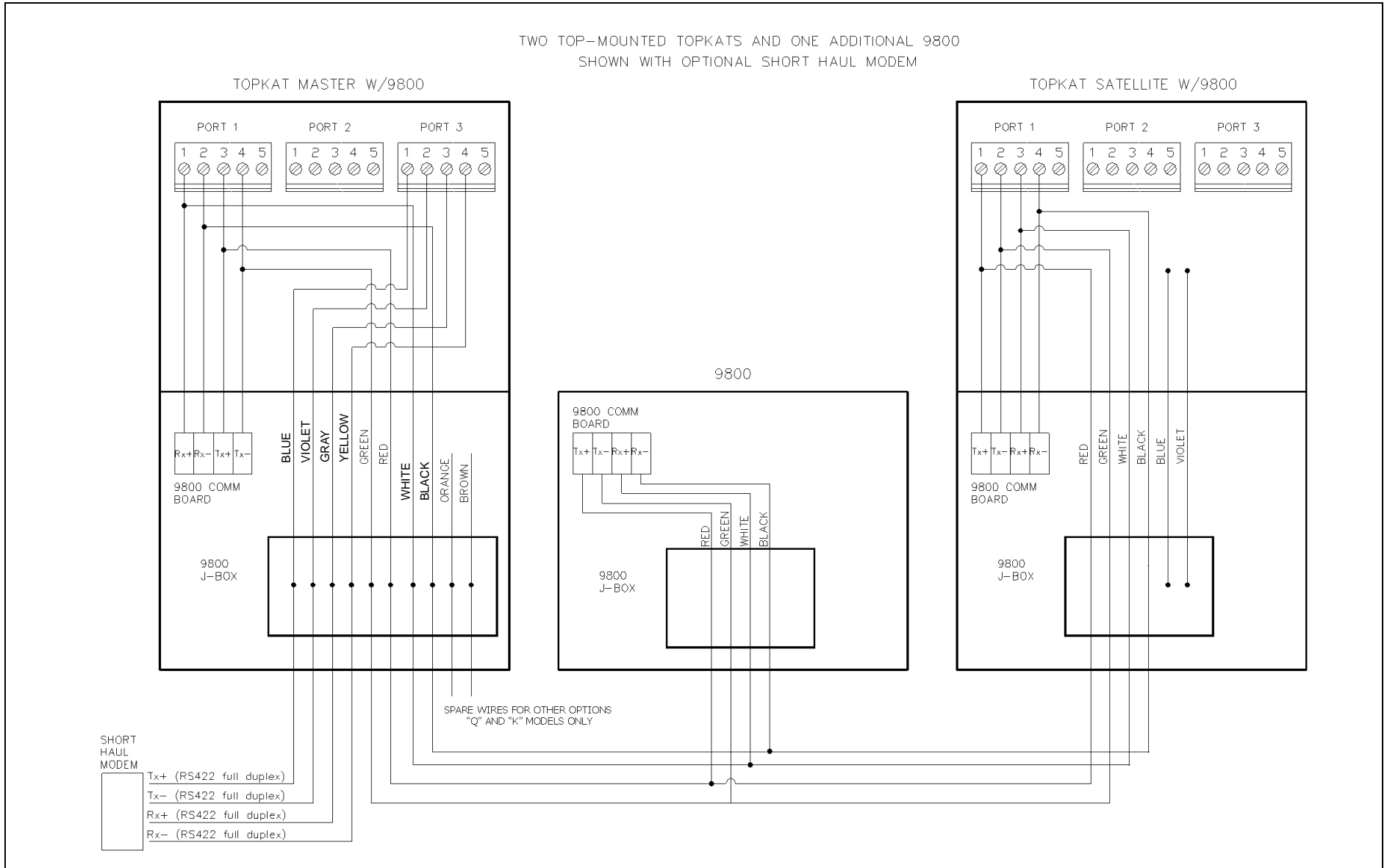

Figure 6-3: Wiring Diagram: RS-422 - Gasboy Short Haul Modem - Master/Satellite Modem

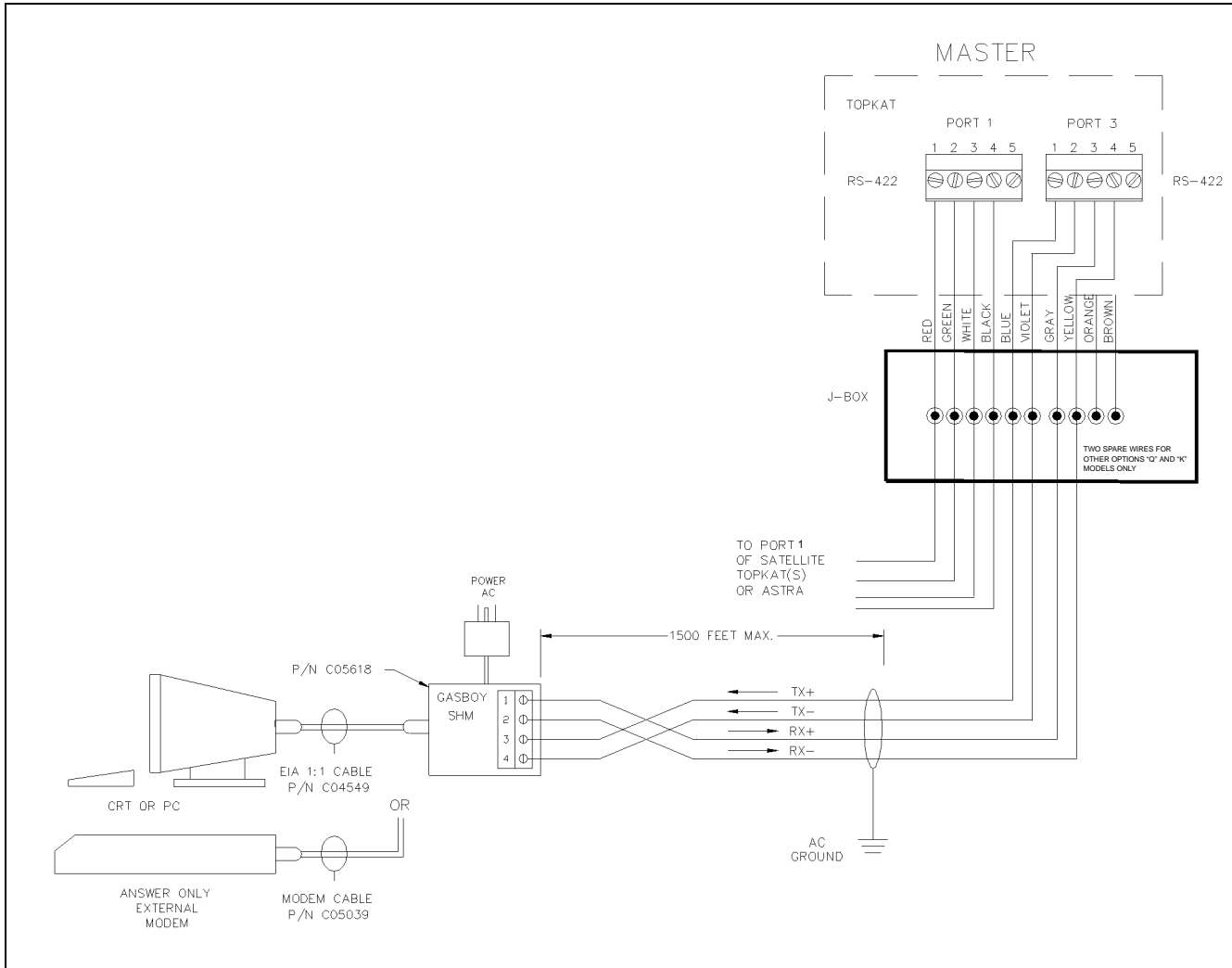
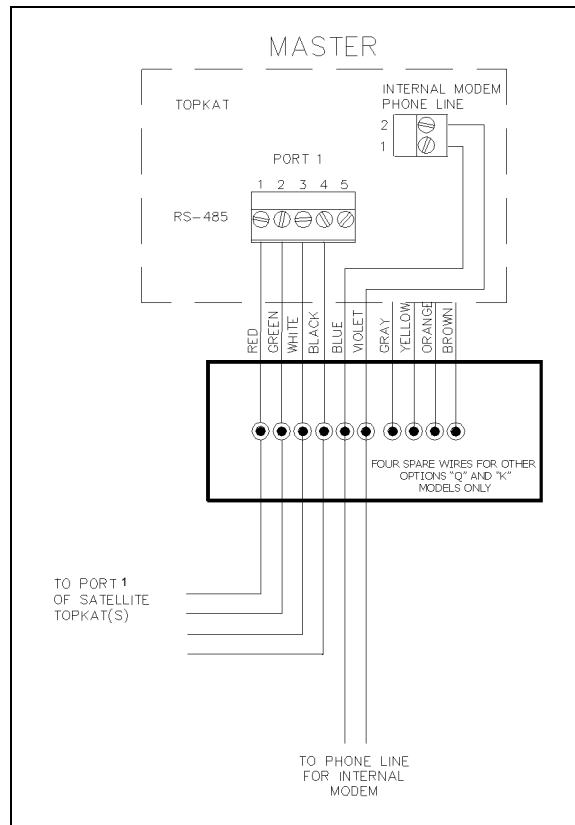
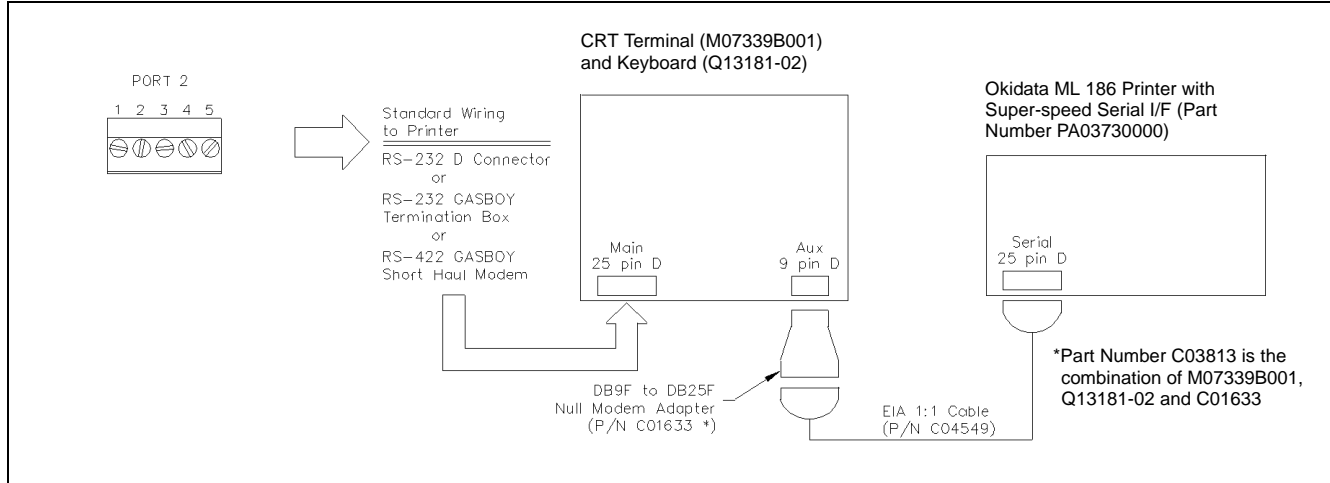

Figure 6-4: Wiring Diagram: Internal Modem with Master/Satellite Option



- Notes: 1) In the TopKAT system, Port 3 is not available for external communication wiring when an internal modem is used. For Port 2, refer to the Master/Satellite Wiring drawings (Figure 6-1 on page 34, Figure 6-2 on page 35, or Figure 6-3 on page 36).
- 2) The K2 jumper for Port 3 should be removed when you use an internal modem. Refer to "Terminal Block ID" on page 24 for the location of K1 and K2 jumpers.

Figure 6-5: Wiring Diagram: CRT Terminal and Okidata Printer



Wiring for Modems

External Modems

The type of phone line required for communication via an external modem is dependant on the type of modem used and the method of communication desired. Refer to the manual that is provided with the modem for specific requirements.

Internal Modems

When the TopKAT internal modem is installed, Port 3 communication is routed through the modem in place of being wired at the DC Junction box. Jumper K2 should be removed. Refer to [“Terminal Block ID”](#) on [page 24](#) for the location of K1 and K2 jumpers. The phone line for the internal modem can be installed in the DC conduit. If you install the modem in the DC conduit, a two twisted-pair shielded cable must be used as specified in [“Communication Requirements”](#) on [page 19](#) and the shield drain wire must be connected to the system AC ground. Check with your local phone company for proper installation of the phone line.

7 – Mechanical Interface Option

Description

The Mechanical Interface option for the TopKAT system allows the unit to control fueling and gather information from up to two mechanical hose outlets (two singles or one twin). The TopKAT system with mechanical interface is mounted on top of a 50 inch high pedestal. All mechanical interface components are mounted within the head of the TopKAT system and all wiring connections are made within the TopKAT system. Electronics or control devices are not present in the pedestal. The TopKAT system with mechanical interface can also be used in a master/satellite configuration.

The mechanical interface includes two solid-state relays and one manual override switch for each hose outlet, which control power to the fuel dispensing equipment (for the override switches to place the pump in MANUAL position, power must be supplied to the TopKAT system). The TopKAT system can handle quantity pulsing rates of 1, 10, 100, 500, and 1000 per gallon measurement and 1, 10, 100 and 250 per liter measurement.

Dimensions

Figure 7-1: TopKAT Dimensions (with Pedestal)

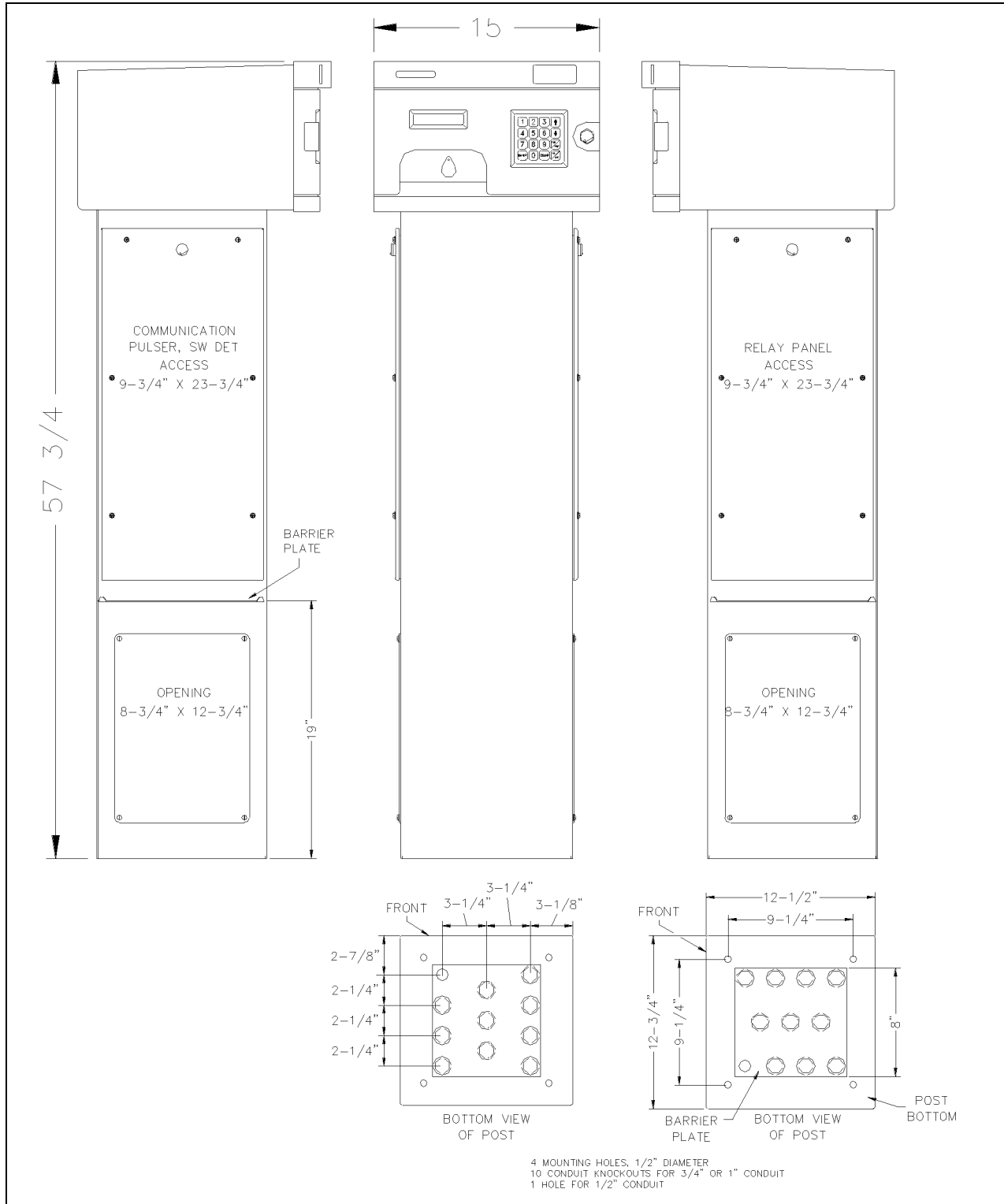

Conduit Layout

Refer to “General Installation” on page 11 for conduit, power requirements, and wire size considerations.

Figure 7-2: TopKAT Conduit Layout

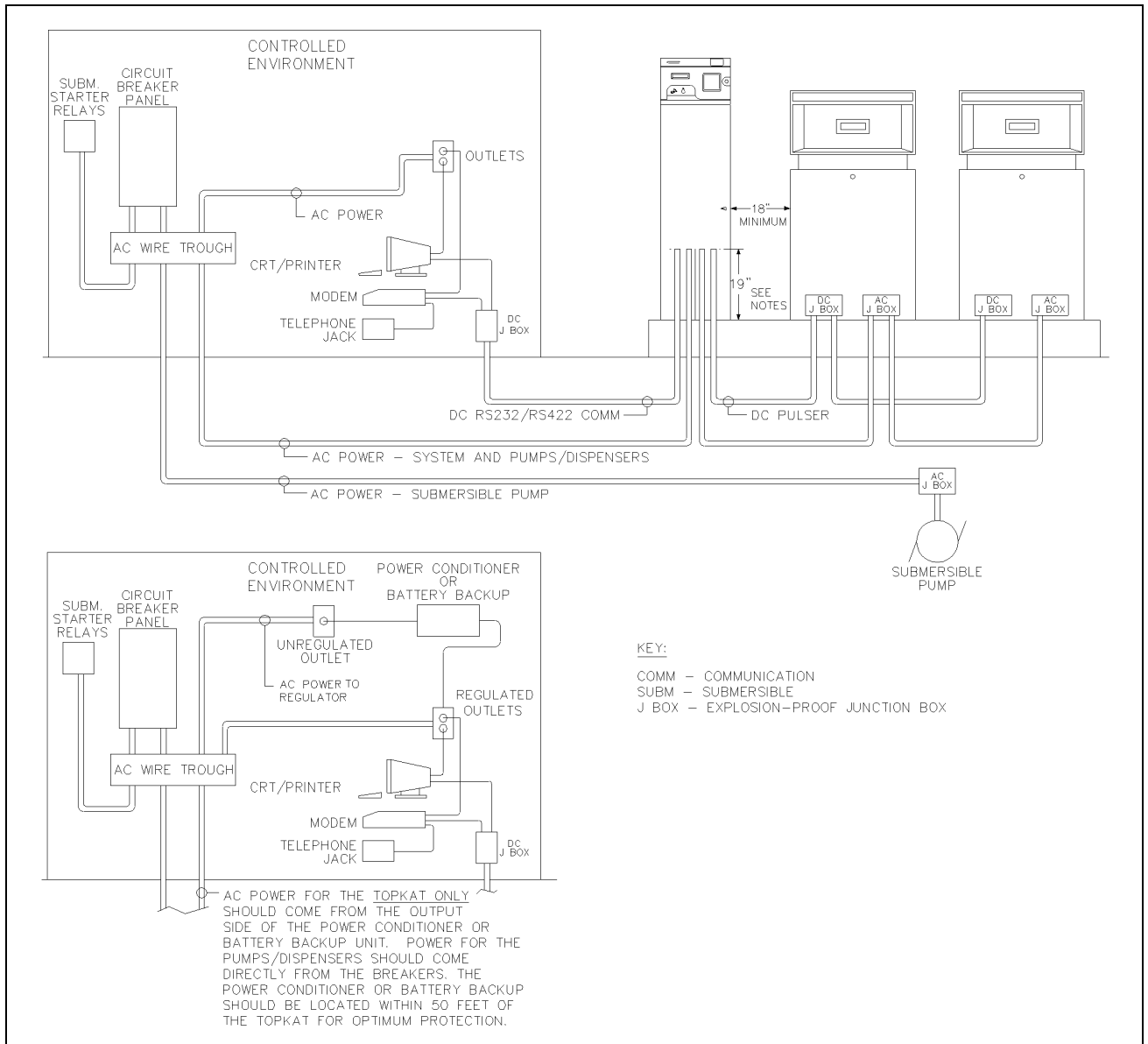

Terminal Block ID

Figure 7-3 shows the mechanical interface components. Refer to “Terminal Block ID” on page 24 for the TopKAT Comm Assembly.

To gain access to the inside of the TopKAT system, proceed as follows:

- 1 Unlock the rear door and open it completely.
- 2 Unscrew the two captive screws holding the hood in place.
- 3 Slide the hood towards the rear of the unit (about 1”) and lift it straight up.

The view in Figure 7-3 is from the rear of the electronic housing assembly.

Figure 7-3: Mechanical Interface Components

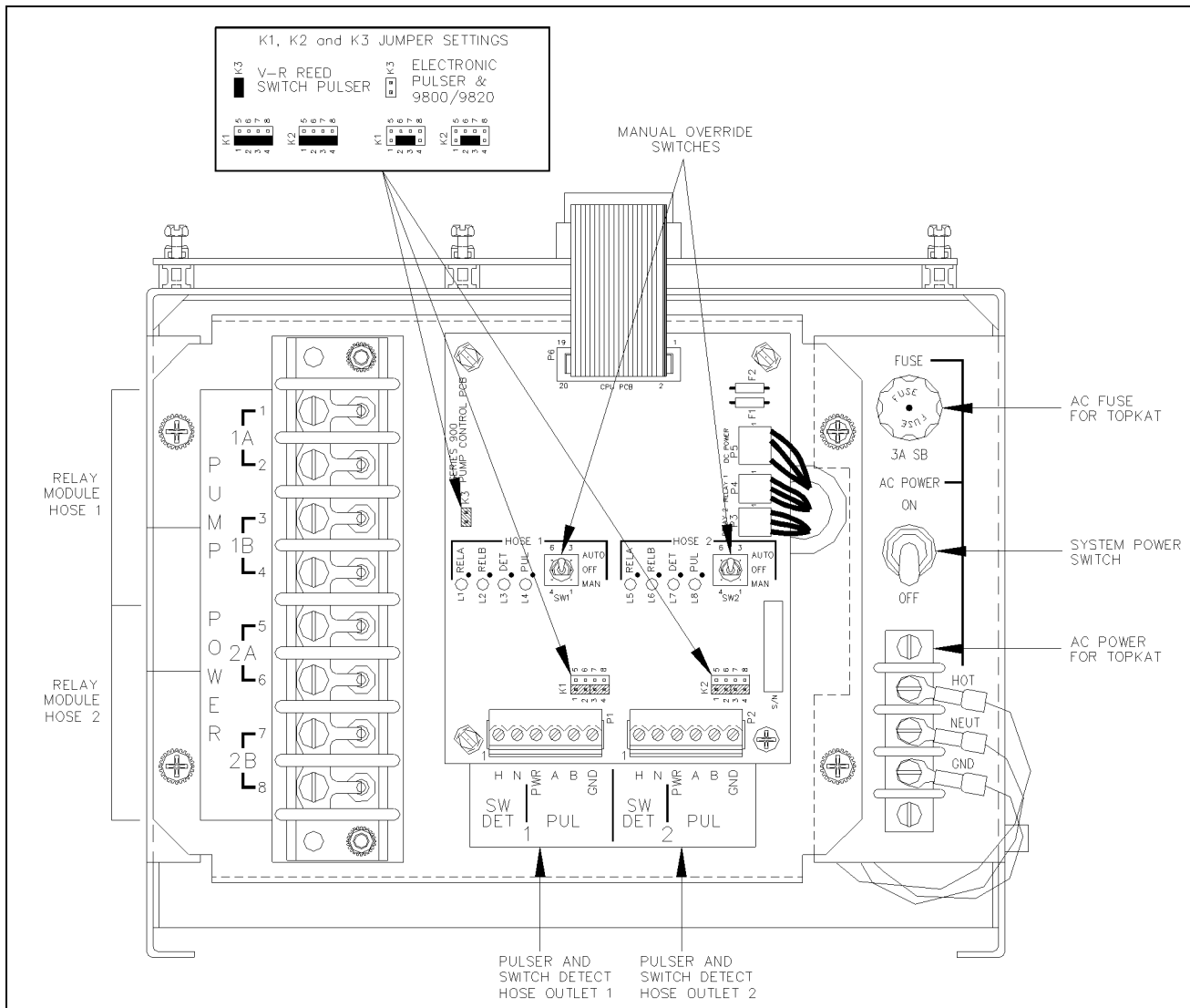

System Pump and Dispenser Wiring

Wiring Precautions

WARNING

To reduce the risk of electrical shock when servicing, turn off all power to the pump/dispenser. In submersible pump applications, turn off all power to the submersible pump and any other dispensers which use that submersible pump. AC power can feed back into a shutoff dispenser when dispensers share a common submersible pump or starter relay.

AVERTISSEMENT

Pour réduire le risque de choc électrique lors de l'entretien/révision, coupez totalement le courant à la pompe/distributeur. Dans les applications de pompe immerisible, coupez totalement le courant à la pompe immerisible et tous autres distributeurs qui utilisent la pompe immerisible. Le courant alternatif peut alimenter de nouveau un distributeur à l'arrêt quand les distributeurs partagent une pompe immerisible commune ou un relais de démarrage.

The quality of the electrical installation is a major factor in maintaining proper safety levels and providing trouble-free operation of your Gasboy pump/dispenser. To ensure a quality installation, follow these rules:

- All wiring must be installed and used in accordance with local building/fire codes, all Federal, State, and Local codes, the National Electrical Code (NFPA 70), NFPA 30, and the Automotive and Marine Service Station Code (NFPA 30A) codes and regulations. Canadian users must also comply with the Canadian Electrical Code.
- Use approved conduit and insulated gasoline and oil resistant copper wiring of the proper size.
- Wire connections must be tightly spliced and secured with a wire nut; close off the open end of the wire nut with electrical tape.
- Install an emergency power cutoff. In addition to circuit breaker requirements of NFPA 70, NFPA 30, NFPA 30A and the Canadian Electrical Code (Canadian users only), a single control that simultaneously removes AC power from all site dispensing equipment is recommended. This control must be readily accessible, clearly labeled, and in accordance with local codes.

In order to provide the highest level of safety to you, your employees, and customers, all employees must be trained as to the location of the power supply and the procedure for turning off power to the entire system.

Control Lines for Mechanical Pumps/Dispensers

Descriptions of the control lines are provided to familiarize the installer with the control inputs and outputs that are used to control a mechanical pump/dispenser. Reading these descriptions will give the installer a better working knowledge of the system and aid in planning the site wiring.

Grounding

To ensure proper operation of the equipment and provide the necessary safety factors, this unit must be grounded. A ground wire (preferably green) must be connected between the ground wire of the system and the main electrical service panel. One (1) earth ground connection is required per unit. A ground rod must be installed at the main electrical panel in accordance with the National Electrical Code. This ground rod must be a solid, corrosion-resistant conductor. It should be properly tied into the ground bus strip of the panel. The neutral and ground bus strips must be bonded together (unless prohibited by local codes).

Reset Motor Feed

This is a 115 VAC input which is supplied through the pump handle switch to activate the reset motor. This line should be switched through the TopKAT system and should only be on when the pump/dispenser is authorized or in Manual mode. Without power supplied to this line, the pump/dispenser will not reset when the pump handle is turned on. Two feed lines are provided for twins. This feed is also connected to the input of one of the internal switches of the electric reset. When the reset finishes its cycle, the 115 VAC input to the switch will be passed through as an output, causing the solenoid valve (optional in some models) to open, and the Reset Complete line to indicate 115 VAC.

Pump Motor Feed

This is a 115 VAC input which is supplied to the input side of one of the internal switches of the electric reset. This line should be switched through the TopKAT system and should only be on when the pump/dispenser is authorized or in Manual mode. When the reset finishes its cycle, the 115 VAC input to the switch is passed through as an output causing the pump motor to receive power and begin fueling. Without power to this line, the unit would reset, but be unable to fuel. Two feed lines are provided in twins which contain two motors. The gauge of this wire (and its neutral wire) must be determined according to the size of the motor, the voltage at which the motor will be powered (115 VAC or 230 VAC), and the distance from the breaker panel to the pump. It is possible to combine the pump motor feeds for twins and supply them from one breaker. However, the gauge of the wire needs to be adjusted to handle the load of two motors.

Note: 230 VAC is developed across a motor when the other leg of the motor is connected to a Phase 2 Feed.

Neutral Feed

This is the AC current return line to the breaker panel for all attached devices (pump motor, reset motor, solenoid valves). The gauge of this wire must be equal to that of the pump motor feed (suction pumps) or submersible feed (dispensers).

Submersible Feed, Submersible Drive

This is a 115 VAC input which is supplied to the input side of one of the internal switches of the electric reset. This line must be switched through the TopKAT system and only be on when the pump/dispenser is authorized or in Manual mode. When the reset finishes its cycle, the 115 VAC input to the switch is passed through as an output (submersible drive) to drive a starter relay or to directly drive a submersible motor up to 3/4 HP at 115 VAC or 1-1/2 HP at 230 VAC. Any submersible motor exceeding this limitation must use a starter relay.

Note: 230 VAC is developed across a motor when the other leg of the motor is connected to a Phase 2 Feed.

Reset Complete (Switch Detect)

This is a 115 VAC output which is used to indicate the reset is complete and the pump/dispenser is ready to dispense the product. Two lines are provided for twins. This line must only be used when monitoring of the pump/dispenser is desired (for example, when used with a fuel management system). This line must be capped when not in use.

Light Feed

This is a 115 VAC input required to power optional fluorescent lights that may be available in a pump/dispenser. In a site configuration using multiple dispensers (or pumps), the power for the lights of up to eight units can be supplied by one breaker. The light feed is not controlled by the TopKAT system.

Light Neutral

This is a return line for AC current from the lights to the breaker panel.

Phase 2 Feed

This is a hot feed which is the opposite phase of the pump motor feed. This line and the pump motor feed are used for 230 VAC motor applications.

Pulser - Mechanical Pump

This supplies a DC output which is provided to indicate the quantity dispensed.

Control Lines for Gasboy 9800 or 9820 Electronic Pumps/Dispensers

Note: This section pertains to 9800 electronic pumps/dispensers running as mechanical units (standalone operation). This scenario would only be used when controlling two pumps: one mechanical and one electronic running as mechanical, from a single TopKAT system.

Descriptions of the control lines are provided to familiarize the installer with the control inputs and outputs that are used to control the Series 9800 and 9820 dispensing units. Reading these descriptions will give the installer a better working knowledge of the system and aid in planning the site wiring.

The Series 9800 may be provided for use with 230 VAC power for international applications. The operating voltage for control lines to these units is shown in parentheses as (230 VAC International).

Ground

To ensure proper operation of the equipment and provide the necessary safety factors, a good ground line must be provided. A ground wire (preferably green) must be connected between the ground wire of the system and the main electrical service panel. One (1) earth ground connection is required per unit. The ground rod is to be a solid, corrosion-resistant conductor and must be installed at the main electrical panel in accordance with the National Electrical Code. It should be properly tied into the ground bus strip of the panel. The neutral and ground bus strips must be bonded together (unless prohibited by local codes).

Micro Feed

The Micro Feed is a 115 VAC (230 VAC International) input required to power the microprocessor of the register's electronics. This power must always remain on and must be on a separate breaker from the control lines (Control/Pump Motor Feed or Control/Subm Feed - Side 1, Side 2). This must also be on a separate breaker from the fluorescent lights to reduce electrical noise and allow for separate control of the lights. In a site configuration using multiple dispensing units, the power for the microprocessors of up to 8 units can be supplied by one breaker.

Micro Neutral

The Micro Neutral is a return line for AC current from the microprocessor of the dispensing unit to the breaker panel.

Control/Pump Motor Feed

The Control/Pump Motor Feed is a 115 VAC (230 VAC International) input which is required to power and authorize the control line. This line is used to provide authorization for the dispensing unit (when enabled through the DIP switches). A resistor assembly must be installed between the Control Feed line and Feed Neutral to prevent false triggering of the authorization input. The resistor assembly is 8.2 kilo-ohm, 10 Watt (part number C05818) for 115/230 VAC domestic and 30 kilo-ohm, 10 Watt (part number C06683) for 230 VAC International wiring. Two Control/Pump Motor Feed lines are provided for twins.

The Control/Pump Motor Feed line is used to power the slow flow and fast flow valves (when installed). The power used to control the pump is also provided by this line. It is possible to combine the control lines for twins and supply them from one breaker. However, the gauge of the wire needs to be adjusted to handle the load of two motors. The Reset Complete signal used for external monitoring of the pump also originates from the Control/Pump Motor Feed line.

External Valve

The External Valve line is used to directly power an anti-siphon valve mounted on top of an aboveground tank. The valve must operate at the same voltage as the pump motor and the current draw must not exceed 1 A, or the valve must be switched through an external relay controlled by the External Valve line. Do not connect two or more External Valve lines together. If more than one pump is drawing from the tank, separate anti-siphon valves must be installed, or each External Valve line must operate an external relay which then operates the valve.

Neutral Feed

The Neutral Feed is the AC current return line to the breaker panel for all attached devices (pump motor, solenoid valves).

Control/Submersible Feed (Control/Subm Feed)

The Control/Subm Feed is a 115 VAC (230 VAC International) input which is required to power and authorize the control line. This line is used to provide authorization for the dispensing unit (when enabled through the DIP switches). A resistor assembly must be installed between the Control Feed line and Feed Neutral to prevent false triggering of the authorization input. The resistor assembly is 8.2 kilo-ohm, 10 Watt (part number C05818) for 115/230 VAC domestic and 30 kilo-ohm, 10 Watt (part number C06683) for 230 VAC International wiring. This line also supplies the power which is switched to the slow flow and fast flow valves along with the Reset Complete signal. Two lines are provided for twins.

Units with Standard Submersible Drive (Subm Drive)

Power for the Subm Drive line originates from this input. The submersible starter relay line, in standard dispensers, is not capable of directly powering a submersible pump. A starter relay must be used. The control lines for twin dispensers can be combined together and powered by one breaker if individual control of each side is not desired. In a site configuration using multiple dispensers, the power for the control lines of up to eight hose outlets (eight singles or four twins) can be supplied from one breaker.

Units with Optional Direct Submersible Drive

Power for the Subm Drive line originates from this input. 9800 Series dispensing units equipped with the optional relays for direct submersible pump drive can be connected directly to submersible pumps up to 3/4 HP at 115 VAC or 1-1/2 HP at 230 VAC. The gauge of this wire should be determined according to the size of the motor, the voltage at which the motor will be powered, and the distance from the breaker panel to the pump.

Submersible Starter Drive (Subm Starter Drive)

The Subm Starter Drive is a 115 VAC (230 VAC International) output used to control a submersible starter relay. Two lines are provided for twins. This line is capable of supplying 300 mA of AC current to control the coil of the submersible motor contactor (starter relay). This is sufficient for directly connecting to the popular models. However, refer to the contactor (relay) manufacturer's data sheet for the sealed VA rating. Divide the sealed VA by the coil voltage to determine the current. This line must not be connected directly to the submersible pump, shorted to any conduit or chassis metal, or wired incorrectly, or the CPU PC board will be instantly damaged. This line must be capped when not in use.

Submersible Drive (Subm Drive)

This line is always present for dispensers, but is active only when Subm Drive relays are supplied. The Subm Drive is a 115/230 VAC (230 VAC International) output used to control the submersible starter relay or submersible pump. When connected directly to the submersible pump, the motor size cannot exceed 3/4 HP at 115 VAC or 1-1/2 HP at 230 VAC. Two lines are provided for twins. In cases where both lines are controlling the same starter relay or pump, they can be combined.

Reset Complete (Switch Detect)/Slow Flow

The Reset Complete/Slow Flow is a 115 VAC (230 VAC International) output which is used to indicate that the reset process is complete and the unit is ready to dispense the product. It is required when used with a TopKAT fuel management system. It may also be used to control a remote (satellite) slow flow valve. Two lines are provided for twins.

Phase 2 Feed

The phase 2 feed is a hot feed which is the opposite phase of the pump motor feed. This line and the pump motor feed are used for 230 VAC motor applications. The Phase 2 Feed must be switched through a separate relay to prevent false triggering of the authorization signal.

Light Feed

The Light Feed is a 115 VAC input required to power the fluorescent lights. In a site configuration using multiple dispensers (or pumps), the power for the lights of up to 8 units can be supplied by one breaker. This must be on a separate breaker from the Micro/Heater Feed to reduce electrical noise and allow for separate control of the lights.

Light Neutral

The Light Neutral is a return line for AC current from the lights to the breaker panel. When a separate breaker is not used to control the lights, the light neutral is attached to the Micro Neutral.

Pulser - 9800/9820

CAUTION

The TopKAT Pump Control Printed Circuit Board (PCB) must be set for electronic pulser (100:1 or higher) as shown in "Terminal Block ID" on [page 42](#). Failure to set the Pump Control PCB jumpers properly will damage the TopKAT.

When a 9800 Series dispensing unit is wired to the TopKAT using the mechanical interface, the dispensing unit must include the optional pulser interface PCB (C06425, M05158A001, M05158A002, and M06587A001) to provide a pulse output. This pulser output provides a DC output to indicate the quantity dispensed. This is an open collector output. This output can sink up to 100 milliamps DC at voltages up to 24 VDC. The output pulse rate can be configured by a DIP switch on the 9800 CPU PCB for rates of 1, 10, 100, 250, or 500 pulses per gallon or 1, 10, or 100 pulses per liter. For the 9850 pump, the pulse rates are 1, 10, or 100 pulses per gallon or 1 or 10 pulses per liter. For 9840K (liters), the pulse rate is 10 pulses per liter. An additional output is provided for a twin. A DC ground line from the TopKAT must be connected to the DC ground line provided from the electronic register.

Wiring Diagrams

Figure 7-4: Wiring Diagram: Veeder-Root® Reed Switch Pulsar, 1871 Series 10:1

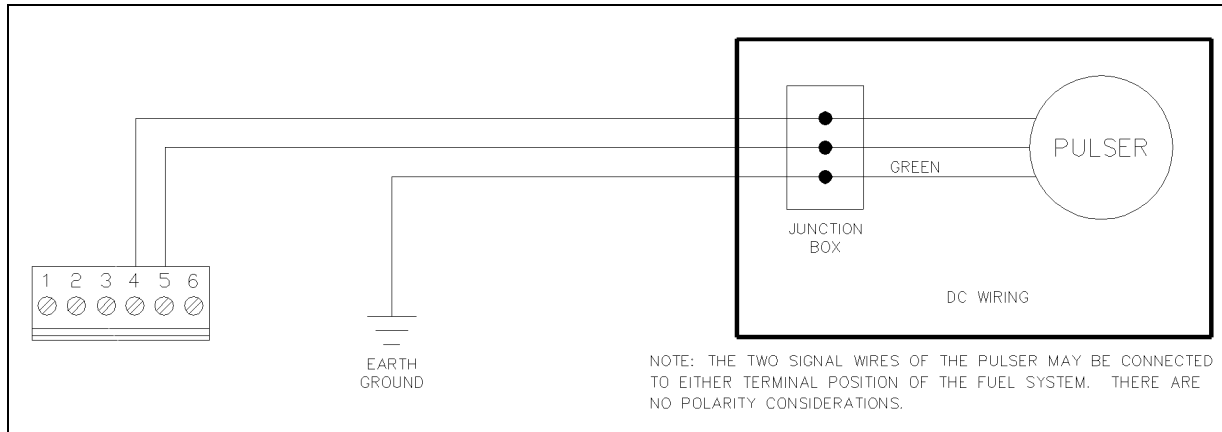
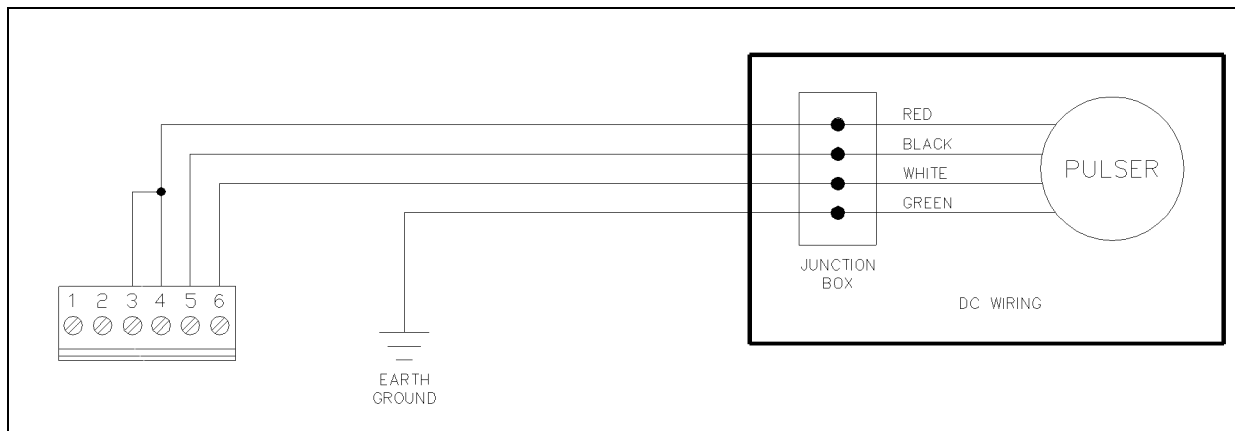

Figure 7-5: Wiring Diagram: Veeder-Root Electronic Pulsar, 7671 Series 100:1



Pulsar Wiring Notes

Notes: 1) All the pulsars shown above are connected to Hose 1.

2) Jumpers on the Pump Control PCB must be properly jumpered according to the pulsar type. This must be done by the person performing the start-up. Power to the system must not be turned on prior to this setup.

3) Refer to [“Conduit Layout”](#) on [page 41](#) for detailed system installation specifications.

- 4) When installed in a separate DC conduit, 18 AWG wires are required for installation. Although it is recommended that DC pulser wires be run in a separate conduit away from AC wires, they can be combined in the same conduit with AC wires if UL-listed cable with the following specifications is used:
- Conductor: 18 AWG stranded wire. Number of conductors to be determined by the pulser
 - Shield: Foil-wrapped 100% coverage and/or tinned copper braid 90% coverage
 - Drain Wire: Stranded, tinned copper, 20 AWG or larger/or braided shield
 - Voltage Rating: Maximum operating voltage of 600 VDC
 - Environmental: Gas and oil-resistant; suitable for wet or dry locations.

Gasboy can supply Belden 1063A (part number C09655) which is a UL-listed, 4-conductor cable that meets the requirements listed above.

Note: Belden 1063A is UL-listed but not CSA-listed.

Figure 7-6: Wiring Diagram: Single Suction Pump, 115 VAC/230 VAC, Veeder-Root Reset

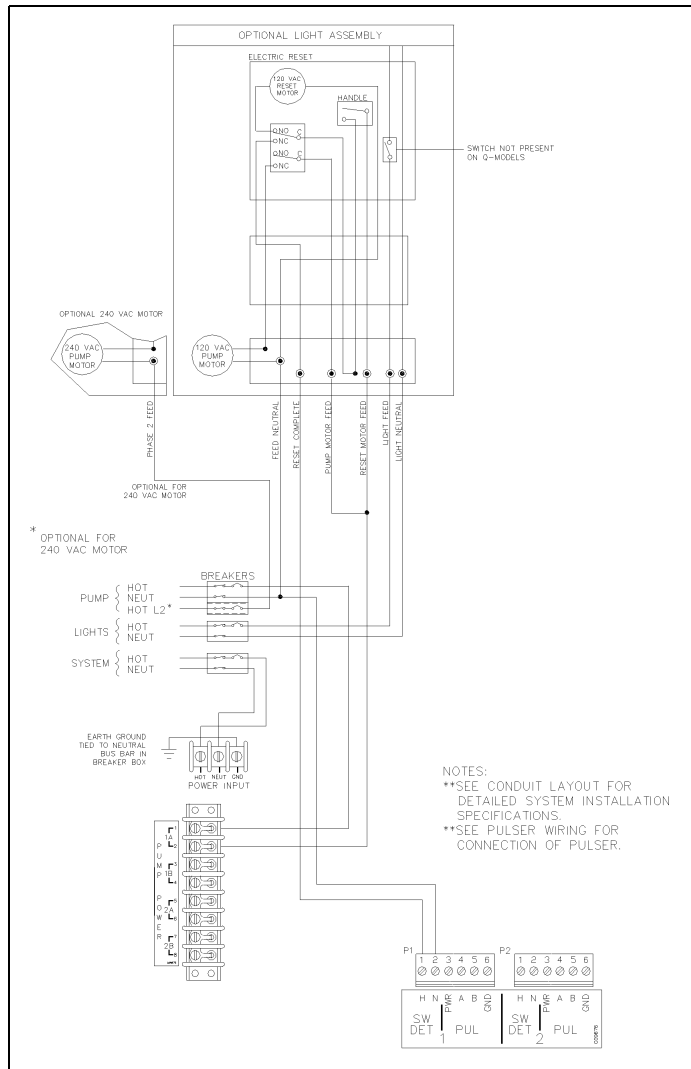

Figure 7-7: Twin Suction Pump, 115 VAC/230 VAC, Veeder-Root Reset

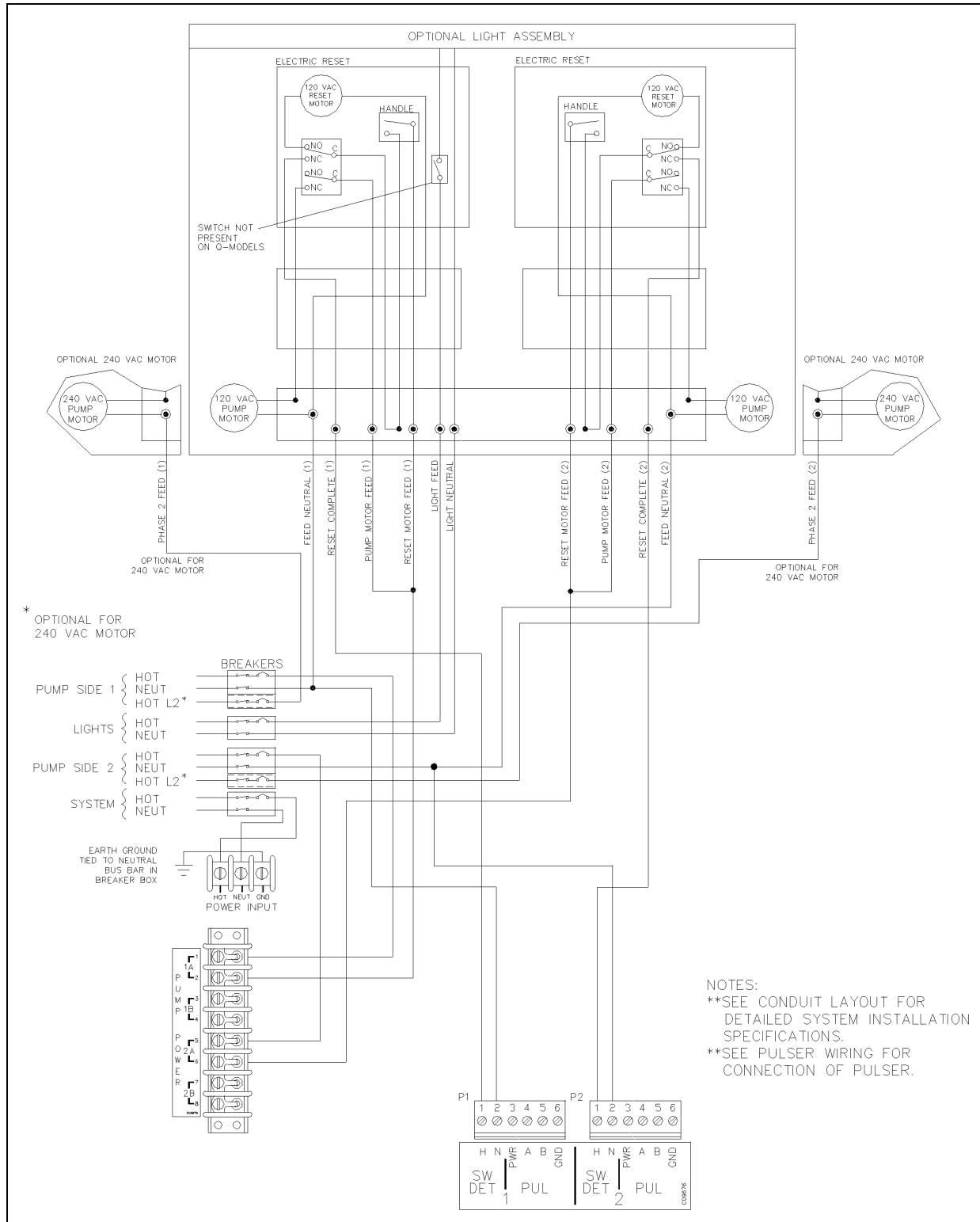

Figure 7-8: Wiring Diagram: Twin Suction Pump, Single Motor, 115 VAC/230 VAC, Veeder-Root Reset

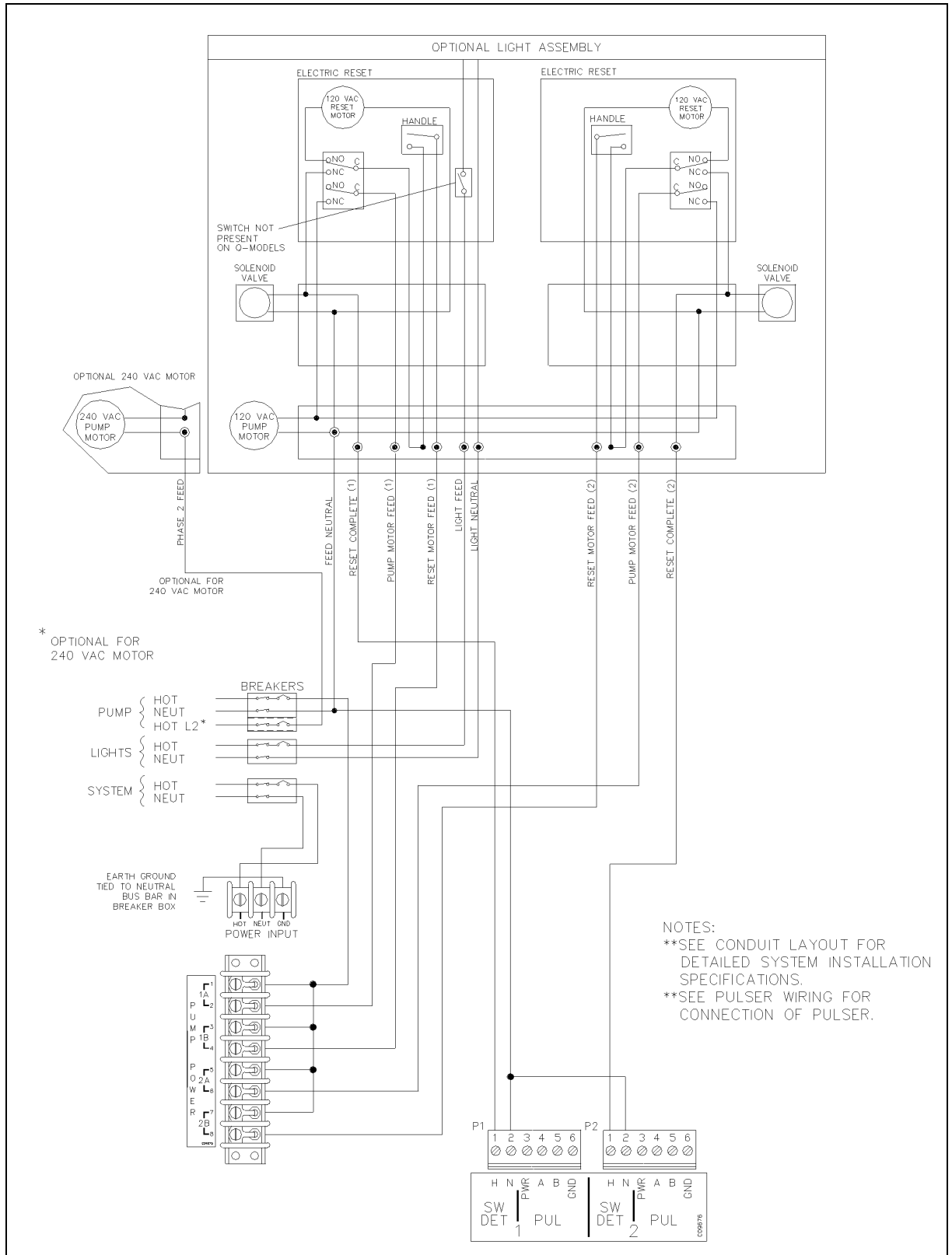

Figure 7-9: Wiring Diagram: Single Dispenser, Veeder-Root Reset

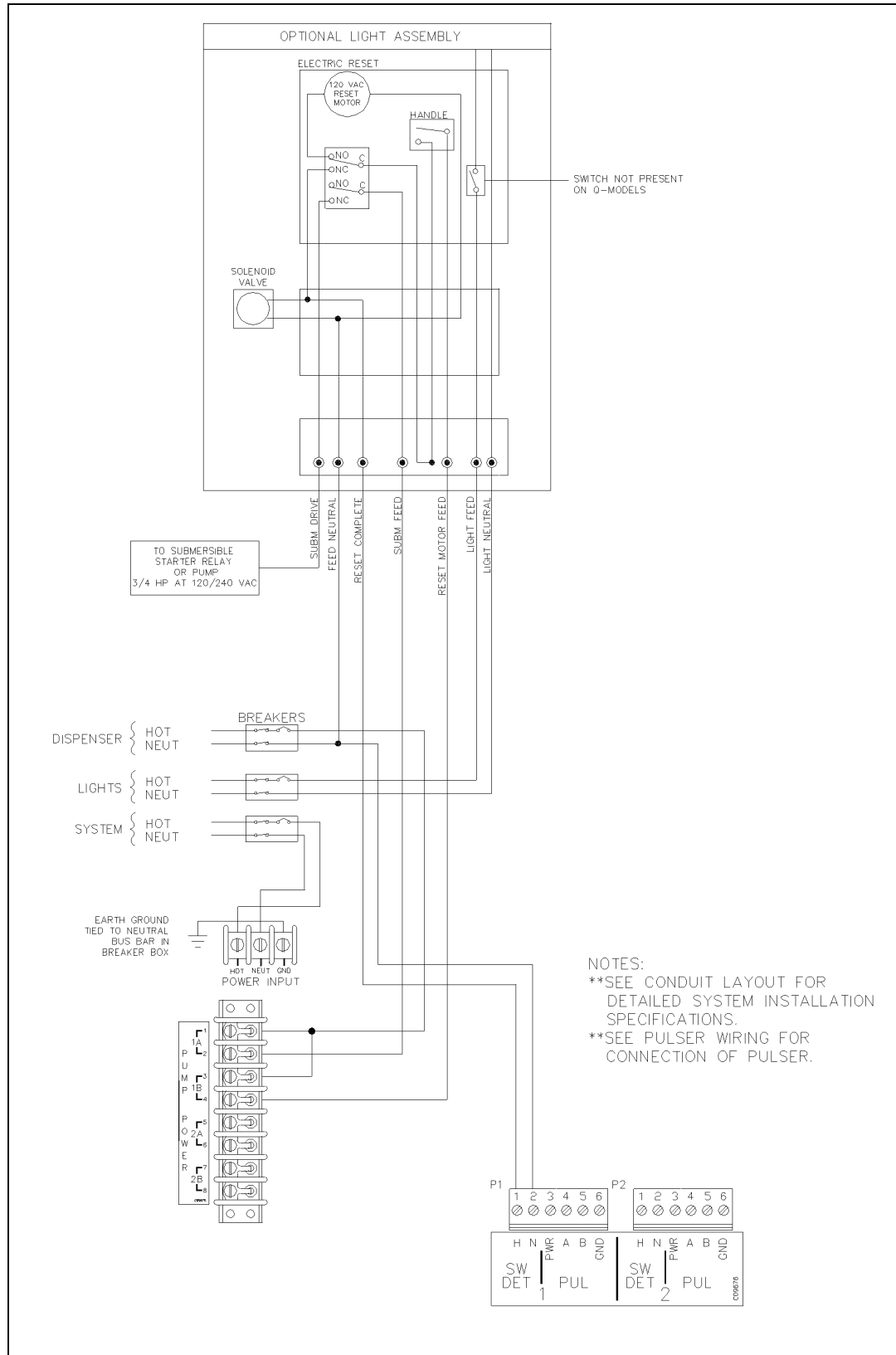

Figure 7-10: Wiring Diagram: Twin Dispenser, Veeder-Root Reset

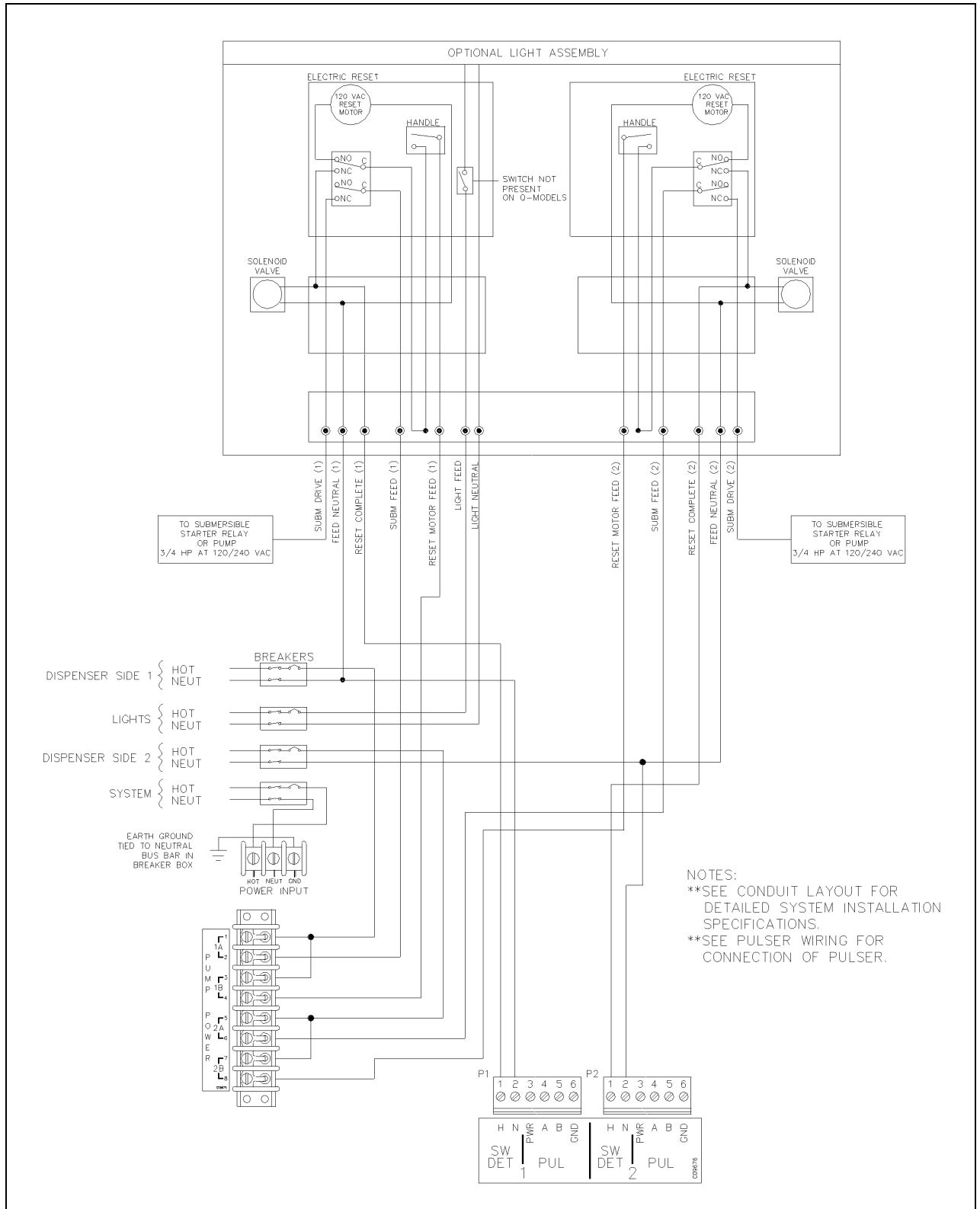
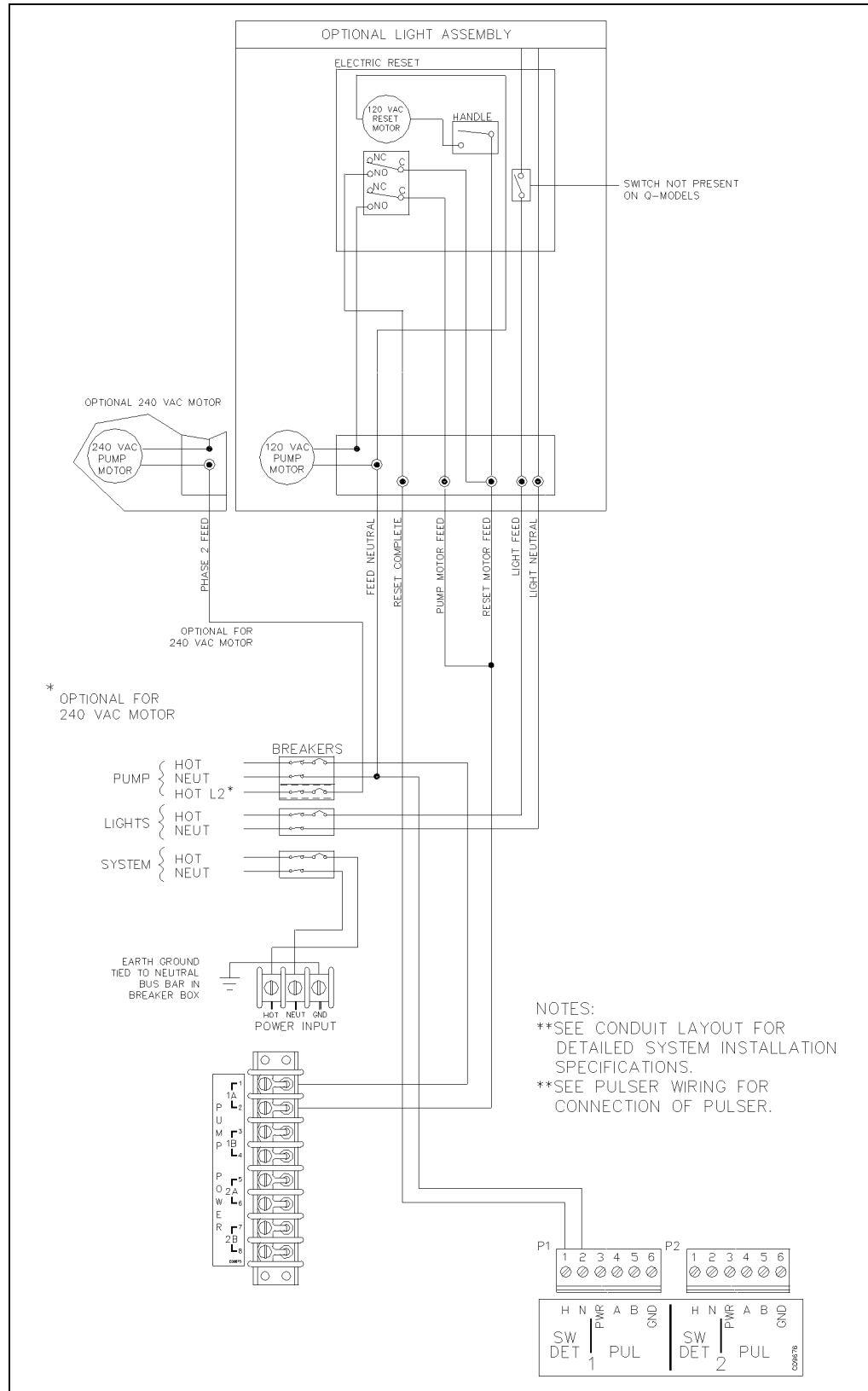

Figure 7-11: Wiring Diagram: Single Suction Pump, 115 VAC/230 VAC, Gasboy Reset



Note: For units with two motors, the pump may have to be operated at 240 VAC to limit the AC current required.

Figure 7-12: Wiring Diagram: Twin Suction Pump, 115 VAC/230 VAC, Gasboy Reset

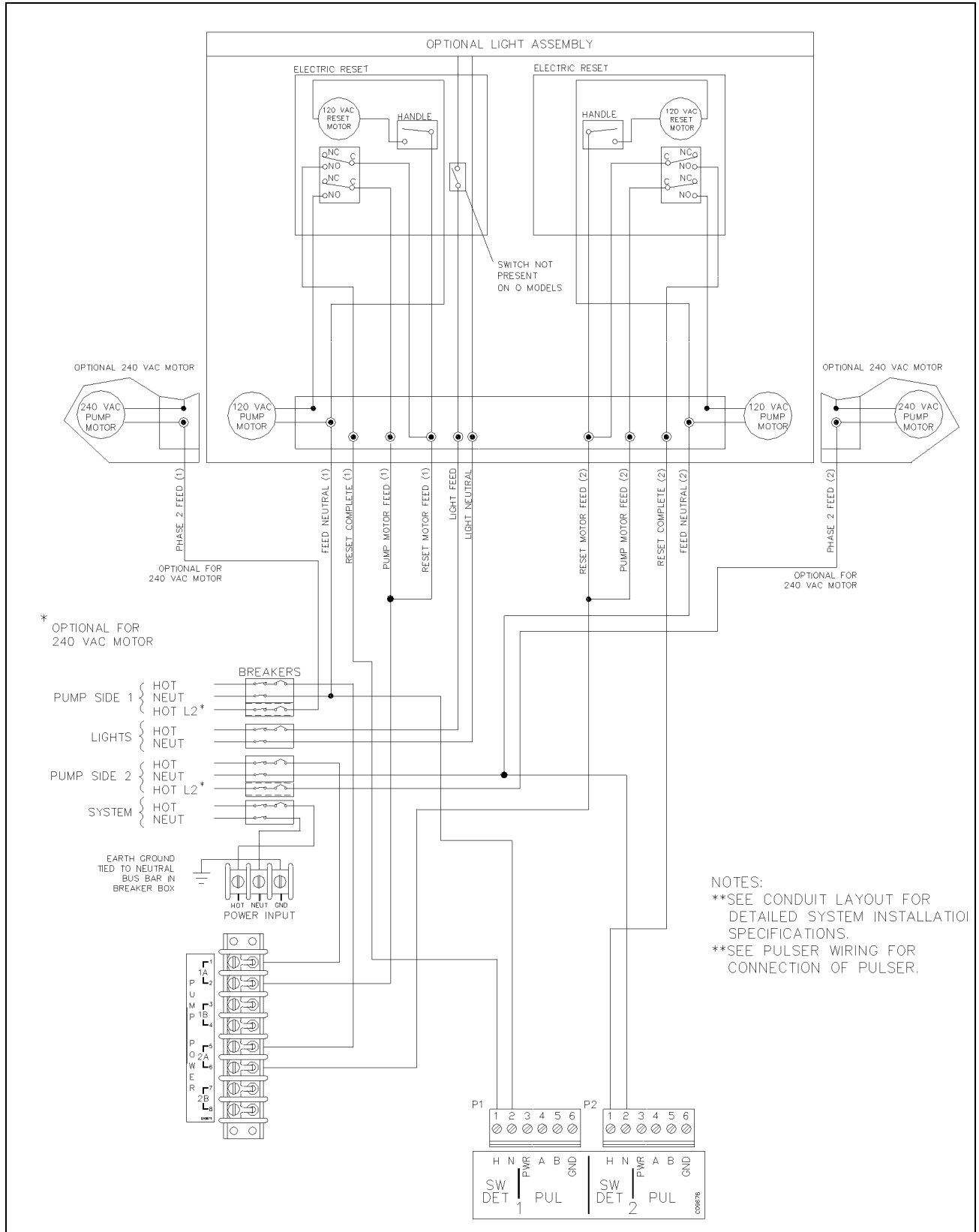

Figure 7-13: Wiring Diagram: Twin Suction Pump, Single Motor, 115 VAC/230 VAC, Gasboy Reset

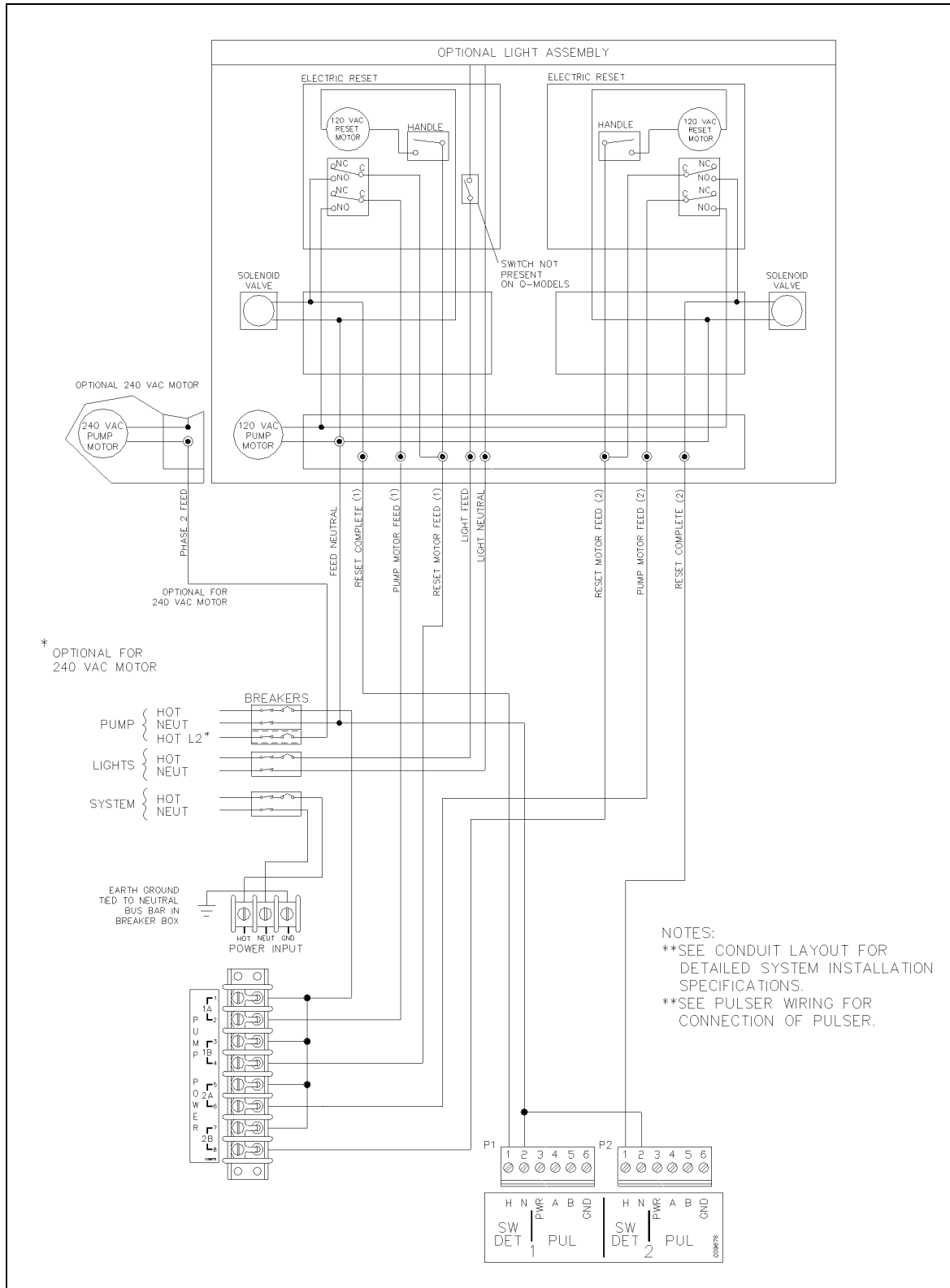

Figure 7-14: Wiring Diagram: Single Dispenser, Gasboy Reset

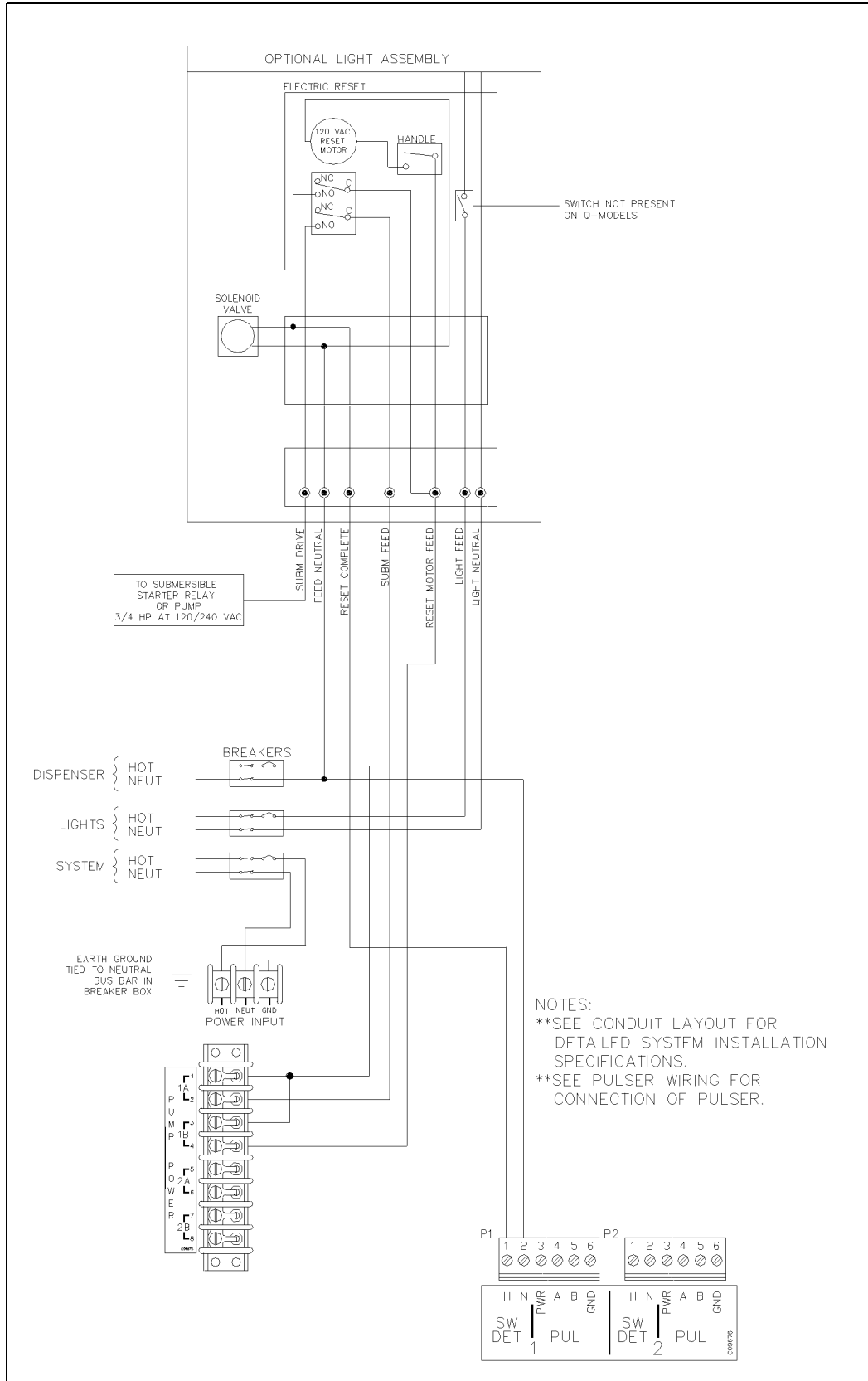

Figure 7-15: Wiring Diagram: Twin Dispenser, Gasboy Reset

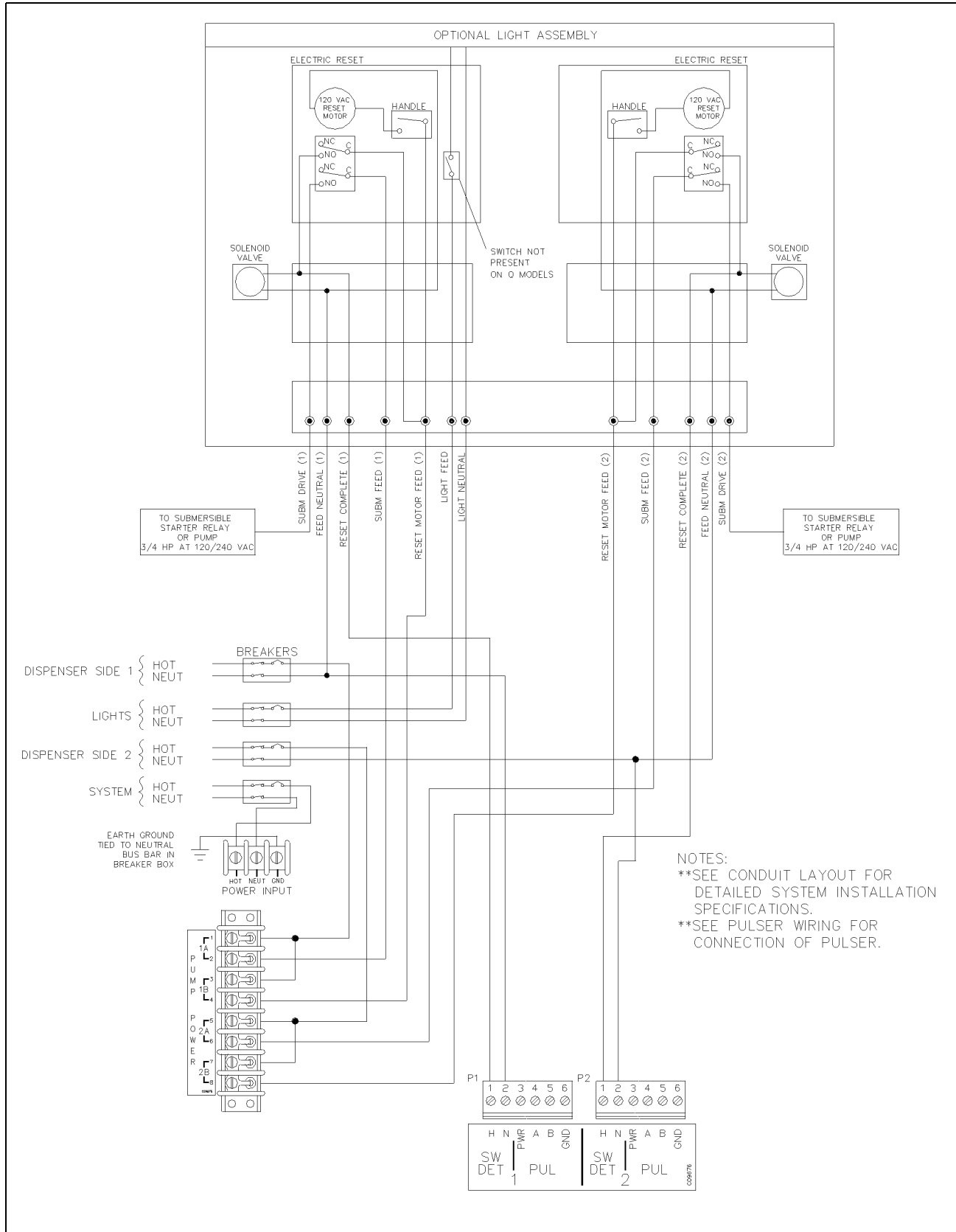

Figure 7-16: Wiring Diagram: 9852, 9853 Pumps

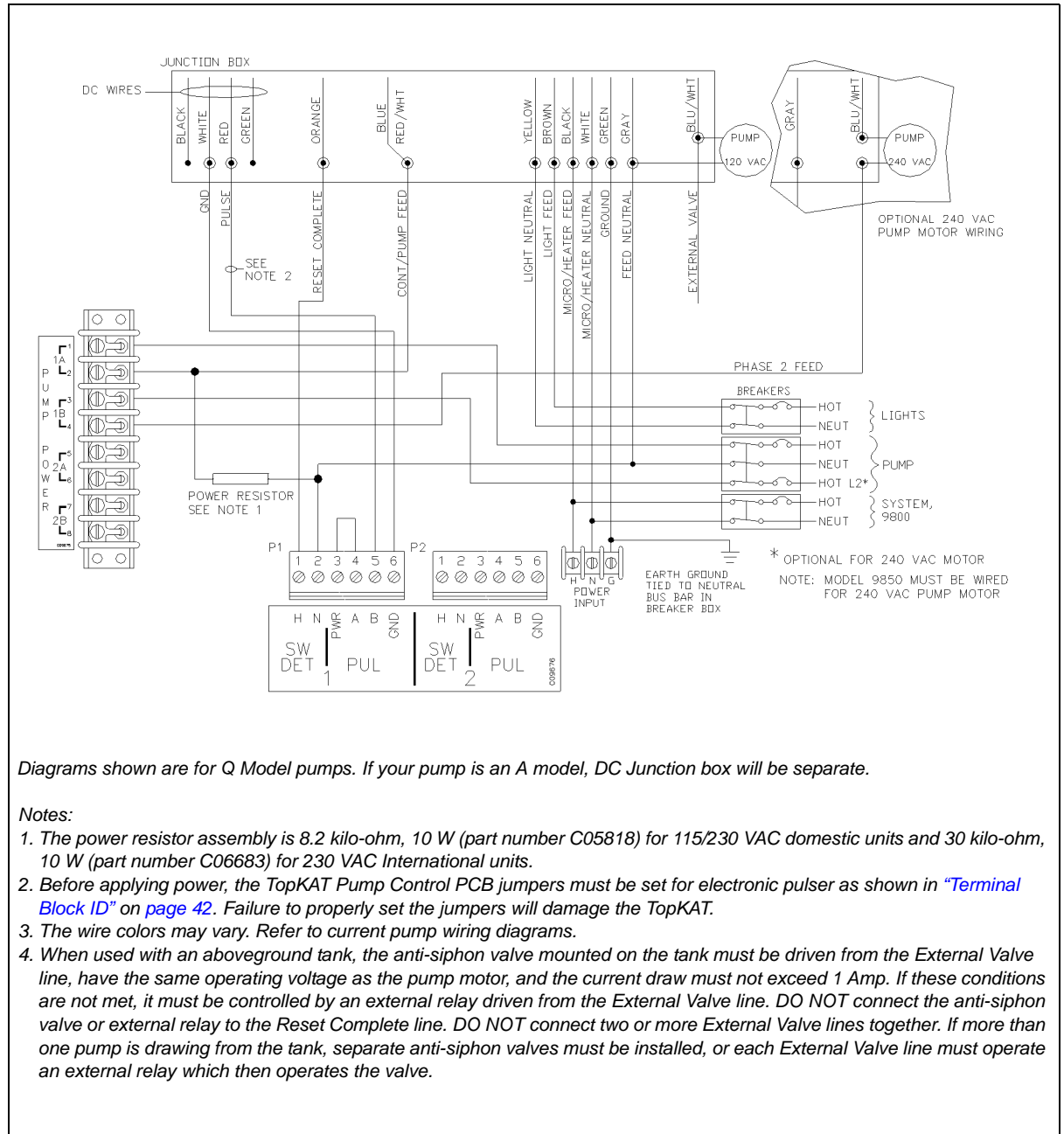

Figure 7-17: Wiring Diagram: 9852TW2, 9853TW2, 9853TW1M Pumps

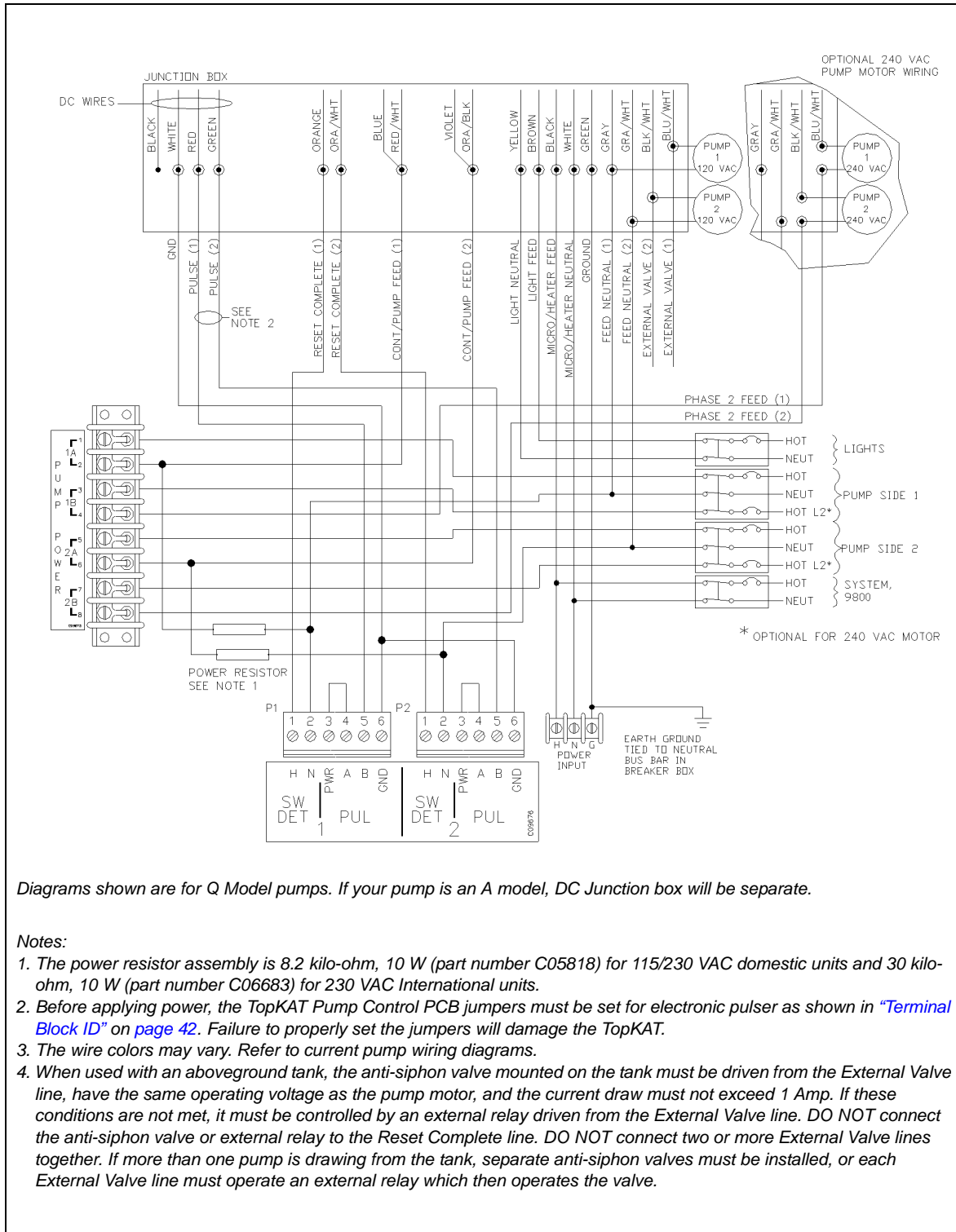
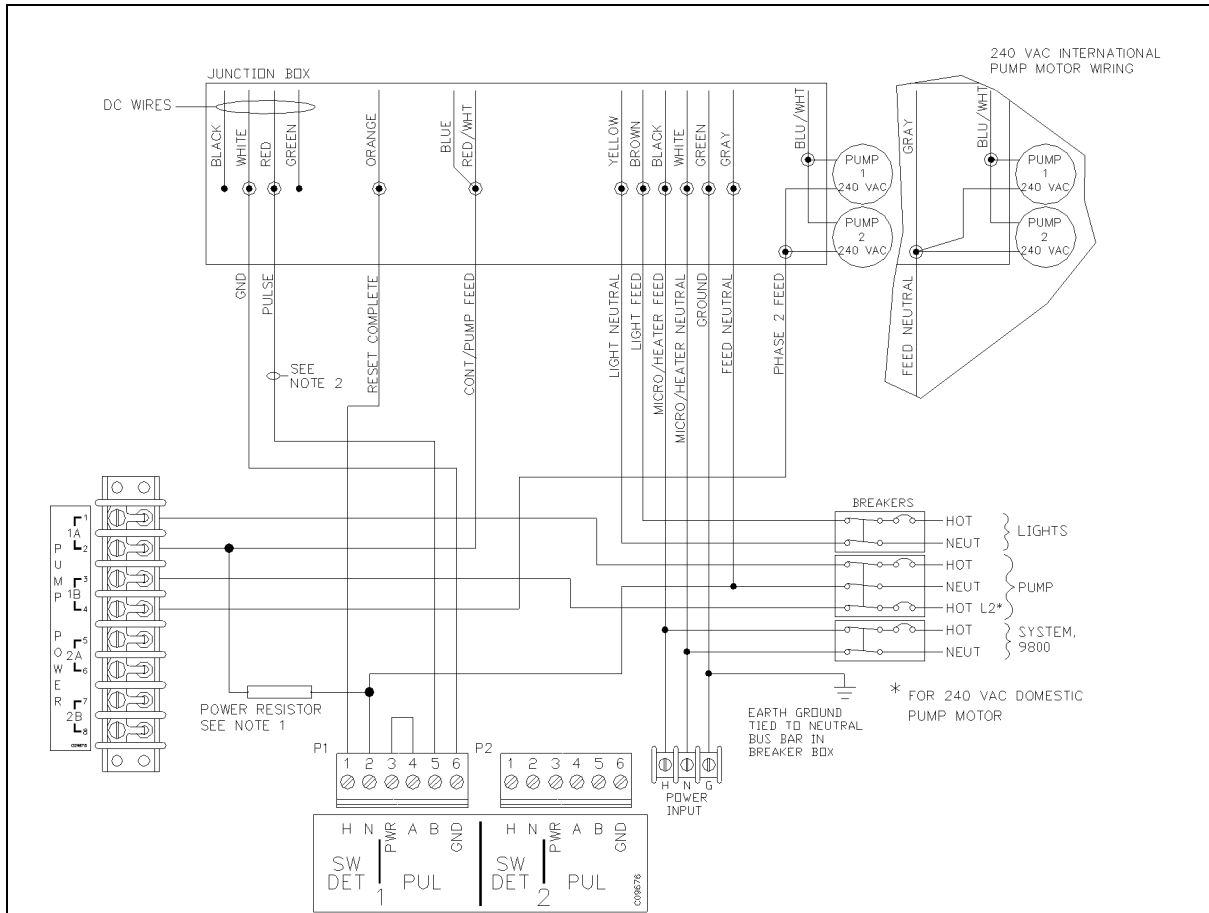

Figure 7-18: Wiring Diagram: 9853HC, 9840 Pumps



Diagrams shown are for Q Model pumps. If your pump is an A model, DC Junction box will be separate.

Notes:

1. The power resistor assembly is 8.2 kilo-ohm, 10 W (part number C05818) for 115/230 VAC domestic units and 30 kilo-ohm, 10 W (part number C06683) for 230 VAC International units.
2. Before applying power, the TopKAT Pump Control PCB jumpers must be set for electronic pulser as shown in "Terminal Block ID" on page 42. Failure to properly set the jumpers will damage the TopKAT.
3. The wire colors may vary. Refer to current pump wiring diagrams.

Figure 7-19: Wiring Diagram: 9852TW1 Pump

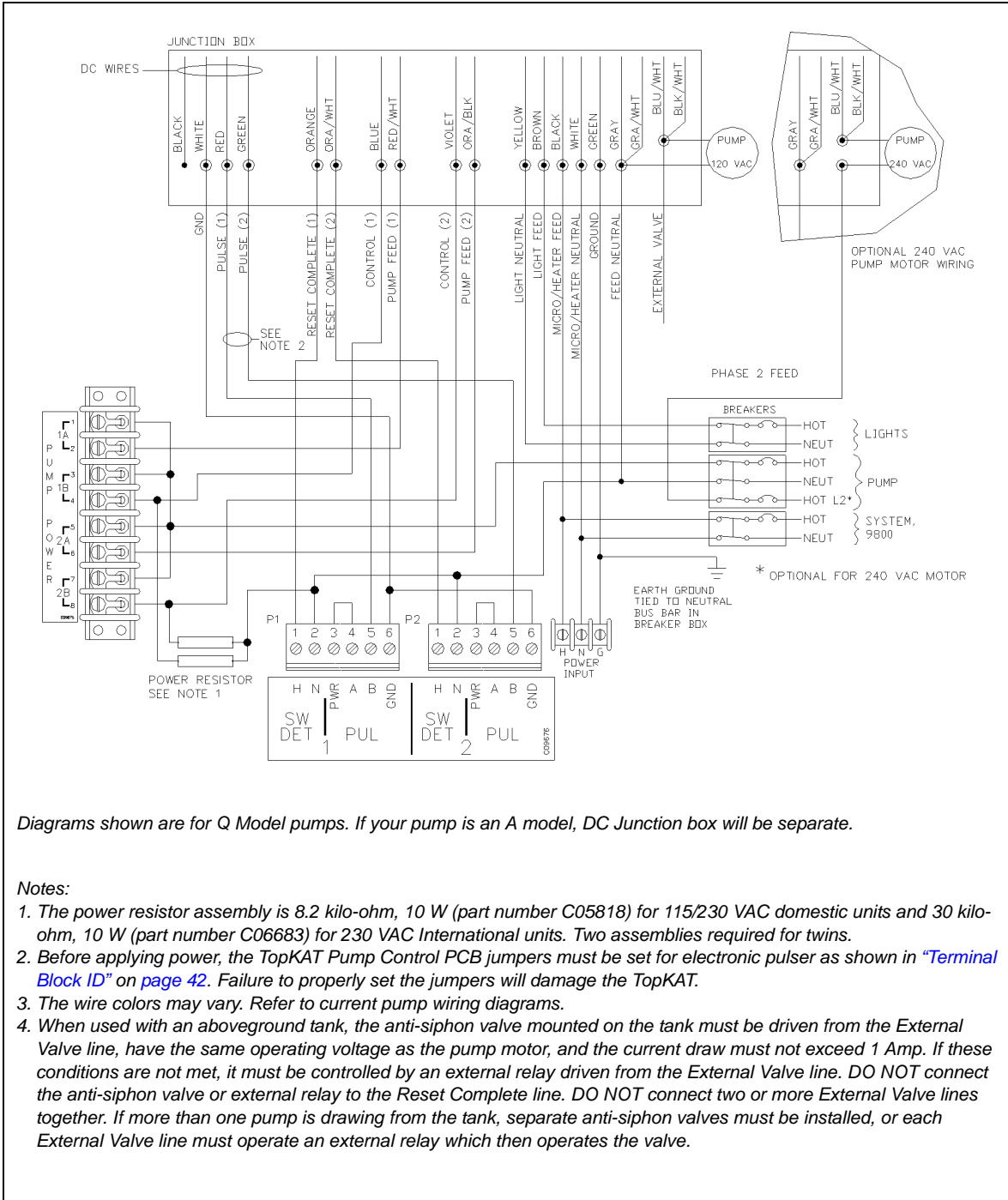

Diagrams shown are for Q Model pumps. If your pump is an A model, DC Junction box will be separate.

Notes:

1. The power resistor assembly is 8.2 kilo-ohm, 10 W (part number C05818) for 115/230 VAC domestic units and 30 kilo-ohm, 10 W (part number C06683) for 230 VAC International units. Two assemblies required for twins.
2. Before applying power, the TopKAT Pump Control PCB jumpers must be set for electronic pulser as shown in "Terminal Block ID" on page 42. Failure to properly set the jumpers will damage the TopKAT.
3. The wire colors may vary. Refer to current pump wiring diagrams.
4. When used with an aboveground tank, the anti-siphon valve mounted on the tank must be driven from the External Valve line, have the same operating voltage as the pump motor, and the current draw must not exceed 1 Amp. If these conditions are not met, it must be controlled by an external relay driven from the External Valve line. DO NOT connect the anti-siphon valve or external relay to the Reset Complete line. DO NOT connect two or more External Valve lines together. If more than one pump is drawing from the tank, separate anti-siphon valves must be installed, or each External Valve line must operate an external relay which then operates the valve.

Figure 7-20: Wiring Diagram: 9852X, 9853X, 9840X, 9850AX, 9850AXS Dispensers

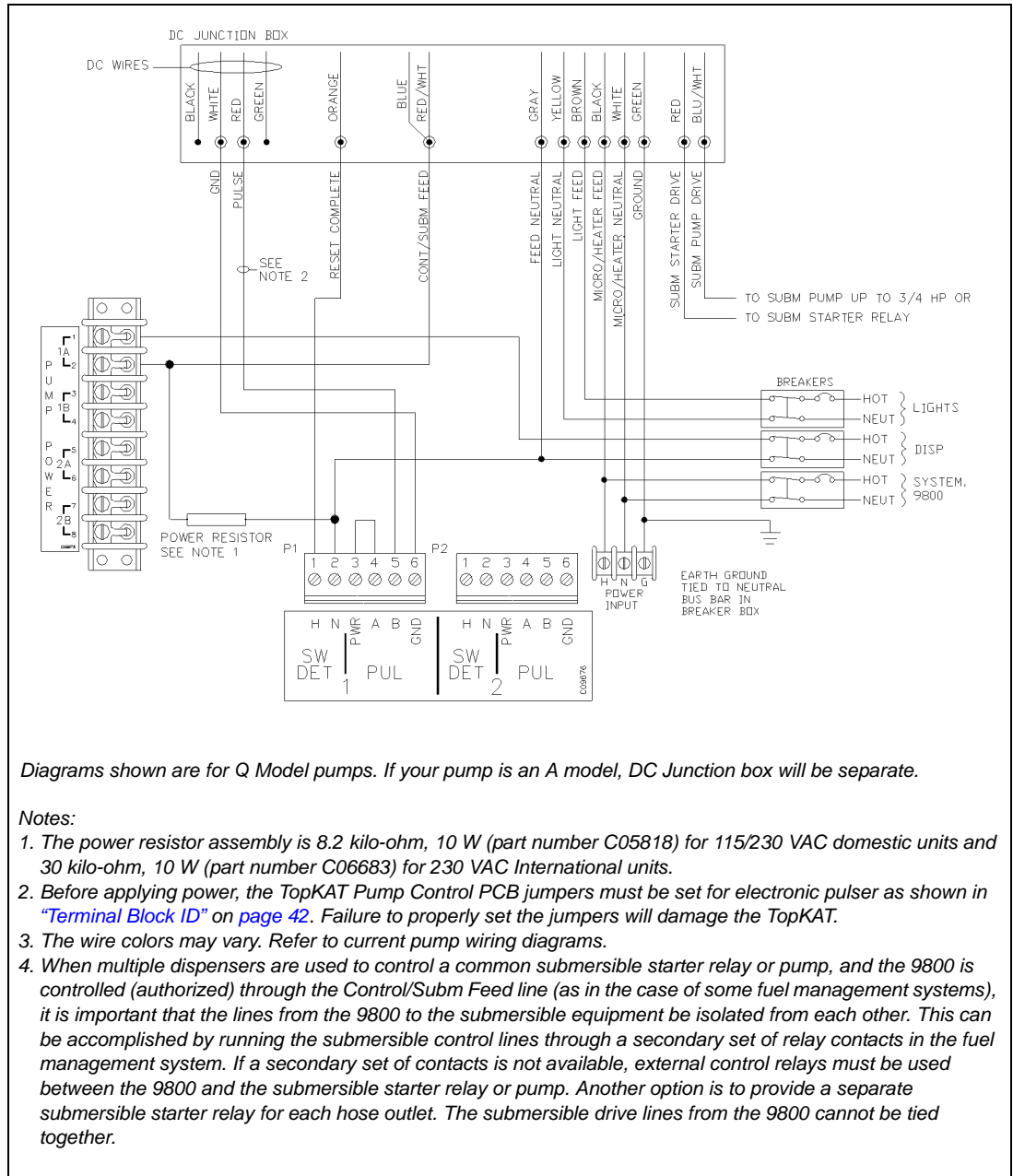
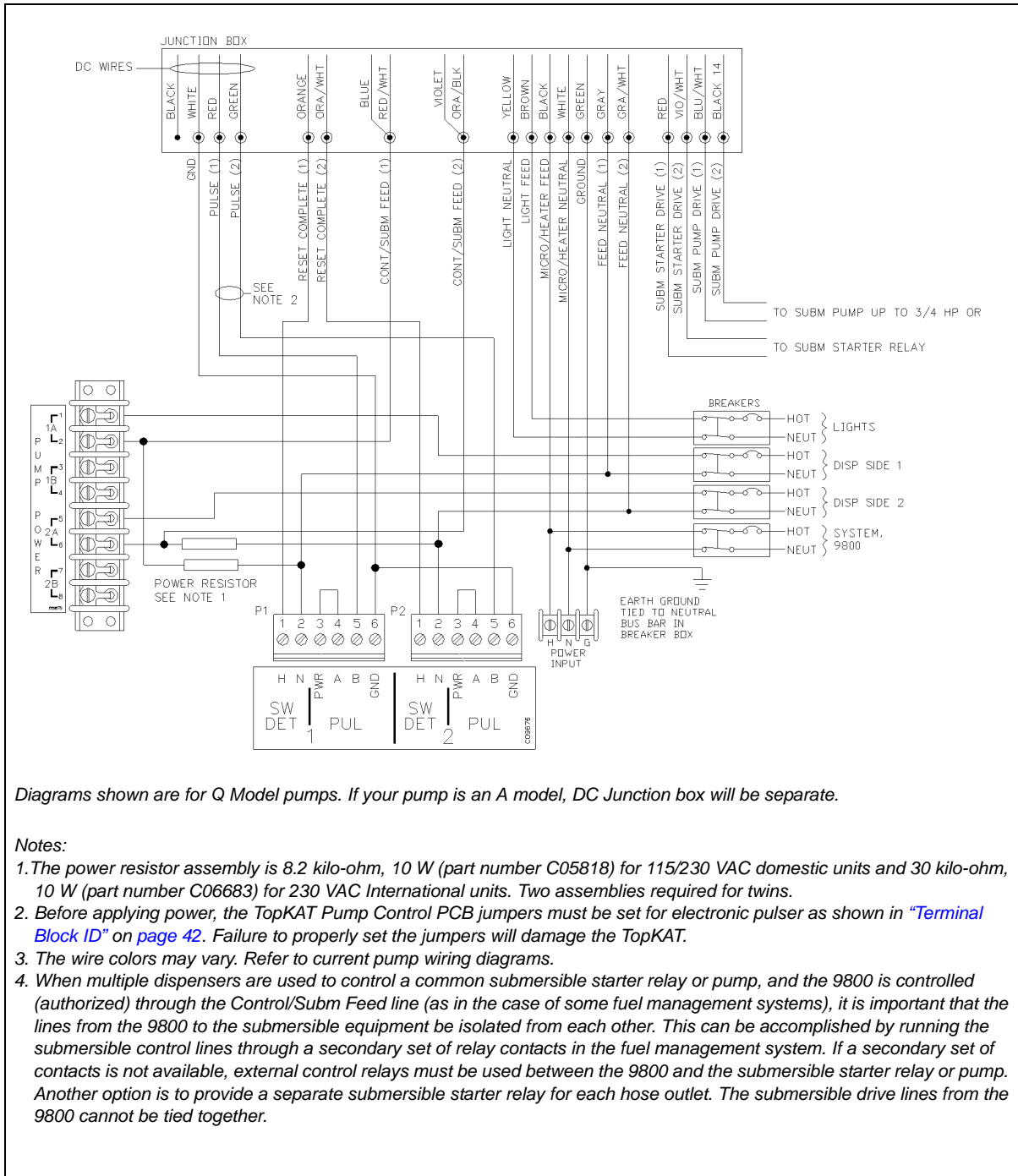

Figure 7-21: Wiring Diagram: 9852XTW1, 9852XTW2, 9853XTW1, 9853XTW2 Dispensers



Diagrams shown are for Q Model pumps. If your pump is an A model, DC Junction box will be separate.

Notes:

1. The power resistor assembly is 8.2 kilo-ohm, 10 W (part number C05818) for 115/230 VAC domestic units and 30 kilo-ohm, 10 W (part number C06683) for 230 VAC International units. Two assemblies required for twins.
2. Before applying power, the TopKAT Pump Control PCB jumpers must be set for electronic pulser as shown in "Terminal Block ID" on page 42. Failure to properly set the jumpers will damage the TopKAT.
3. The wire colors may vary. Refer to current pump wiring diagrams.
4. When multiple dispensers are used to control a common submersible starter relay or pump, and the 9800 is controlled (authorized) through the Control/Subm Feed line (as in the case of some fuel management systems), it is important that the lines from the 9800 to the submersible equipment be isolated from each other. This can be accomplished by running the submersible control lines through a secondary set of relay contacts in the fuel management system. If a secondary set of contacts is not available, external control relays must be used between the 9800 and the submersible starter relay or pump. Another option is to provide a separate submersible starter relay for each hose outlet. The submersible drive lines from the 9800 cannot be tied together.

Figure 7-22: Wiring Diagram: 9820 115/230 VAC Domestic Dispensers

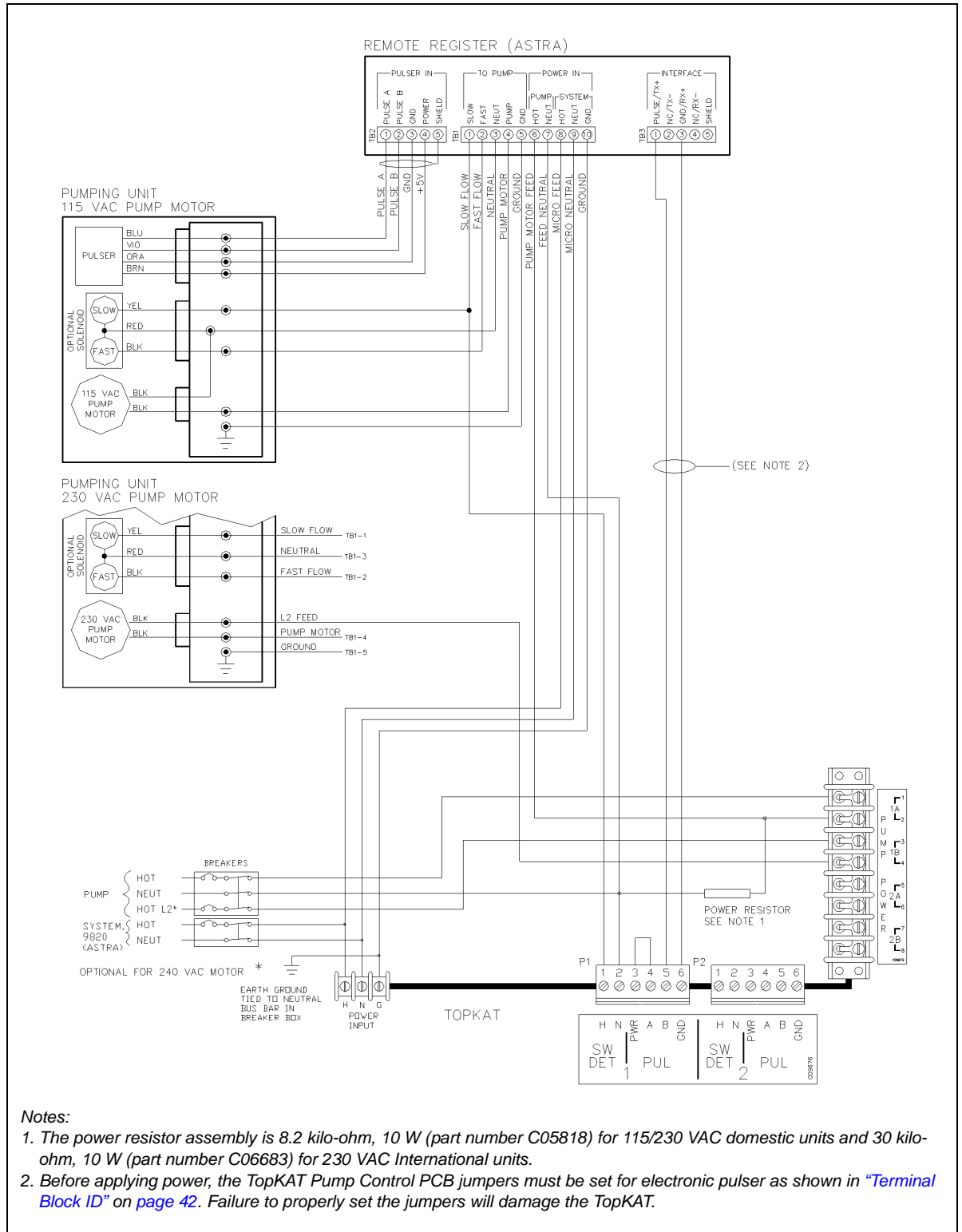

- Notes:
1. The power resistor assembly is 8.2 kilo-ohm, 10 W (part number C05818) for 115/230 VAC domestic units and 30 kilo-ohm, 10 W (part number C06683) for 230 VAC International units.
 2. Before applying power, the TopKAT Pump Control PCB jumpers must be set for electronic pulser as shown in "Terminal Block ID" on page 42. Failure to properly set the jumpers will damage the TopKAT.

Figure 7-23: Wiring Diagram: 9820 230 VAC International Dispensers

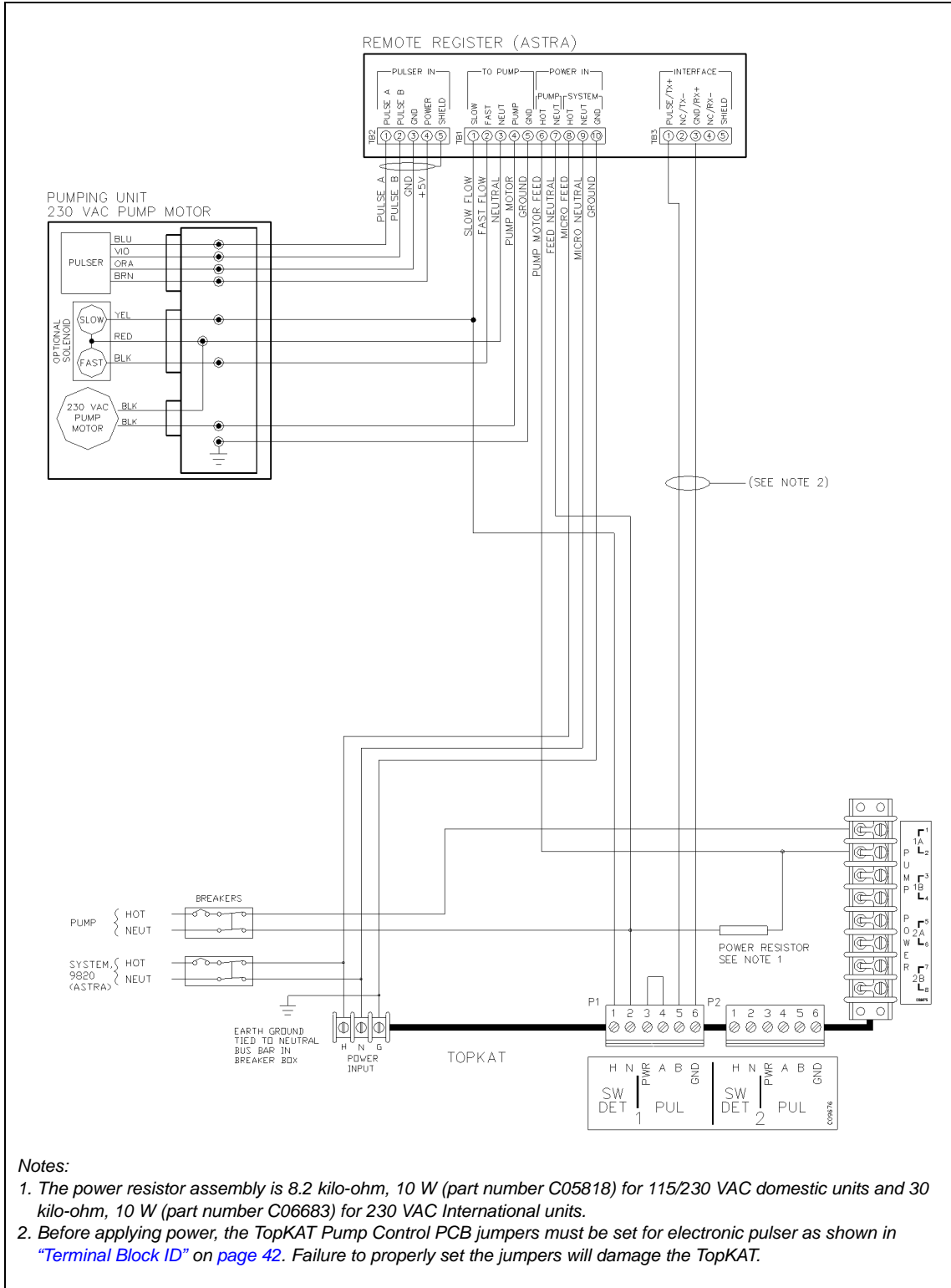

The next four figures show the pin-to-pin layout of the possible wiring schemes for the TopKAT ports. Each port may be wired for any of the wiring schemes provided the installation requirements are met as outlined in [“Communication Requirements”](#) on [page 19](#).

Figure 7-24: Wiring Diagram: RS-232 - D Connector

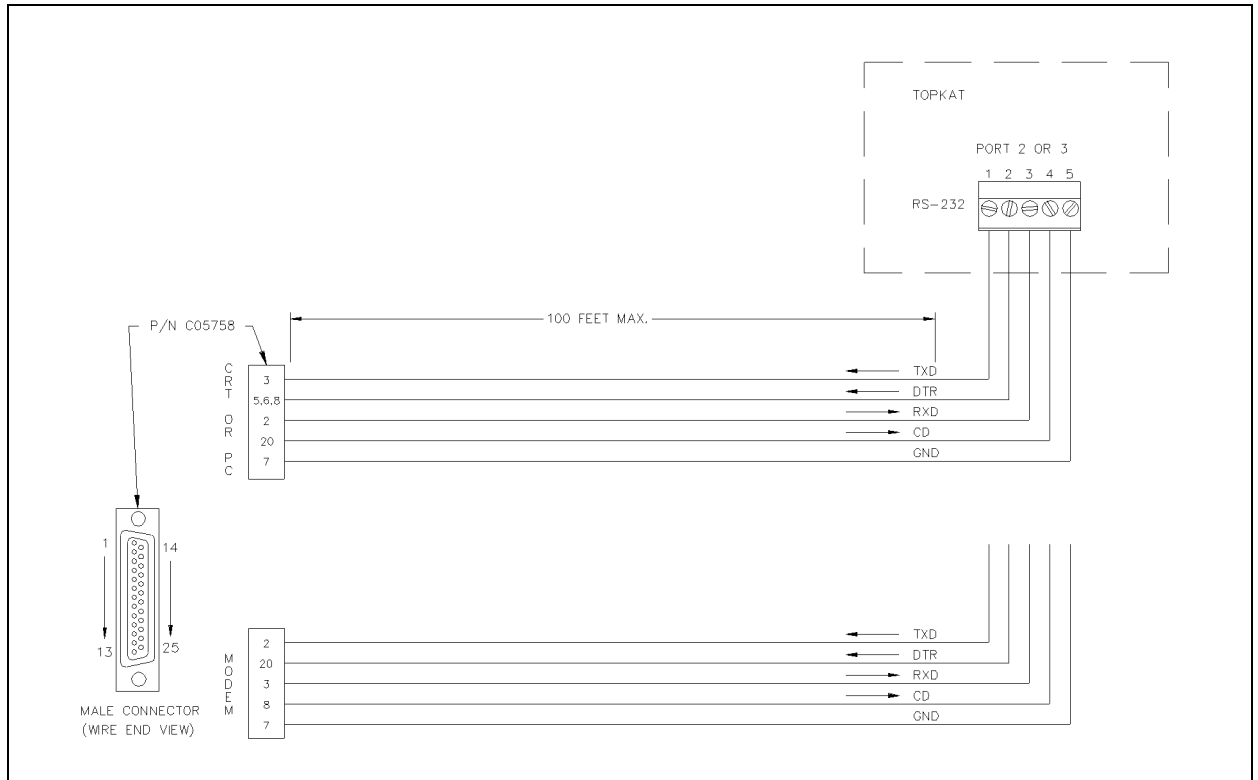

Note: In the TopKAT, the green connector must be connected to P4 on the communication board for Port 2, and P6 for Port 3. The K1 and K2 jumper for the port being used should be set to RS-232. Refer to [“Terminal Block ID”](#) on [page 42](#) for the location of K1 and K2 jumpers.

Figure 7-25: Wiring Diagram: RS-232 - Gasboy Termination Box

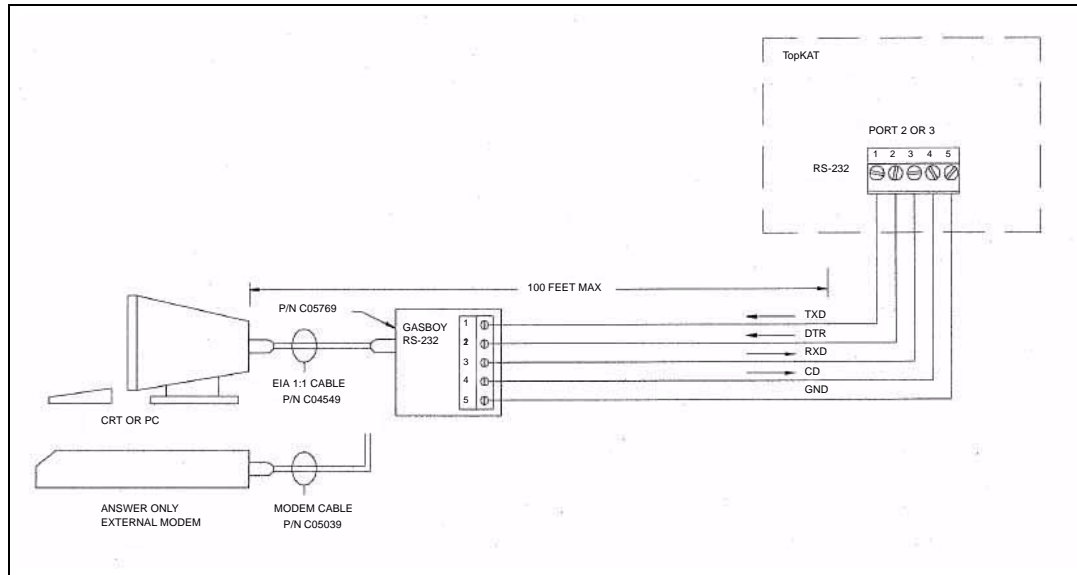

Note: In the TopKAT, the green connector must be connected to P4 on the communication board for Port 2, and P6 for Port 3. The K1 and K2 jumper for the port being used should be set to RS-232. Refer to “Terminal Block ID” on page 42 for the location of K1 and K2 jumpers.

Figure 7-26: Wiring Diagram: RS-422 - Gasboy Short Haul Modem

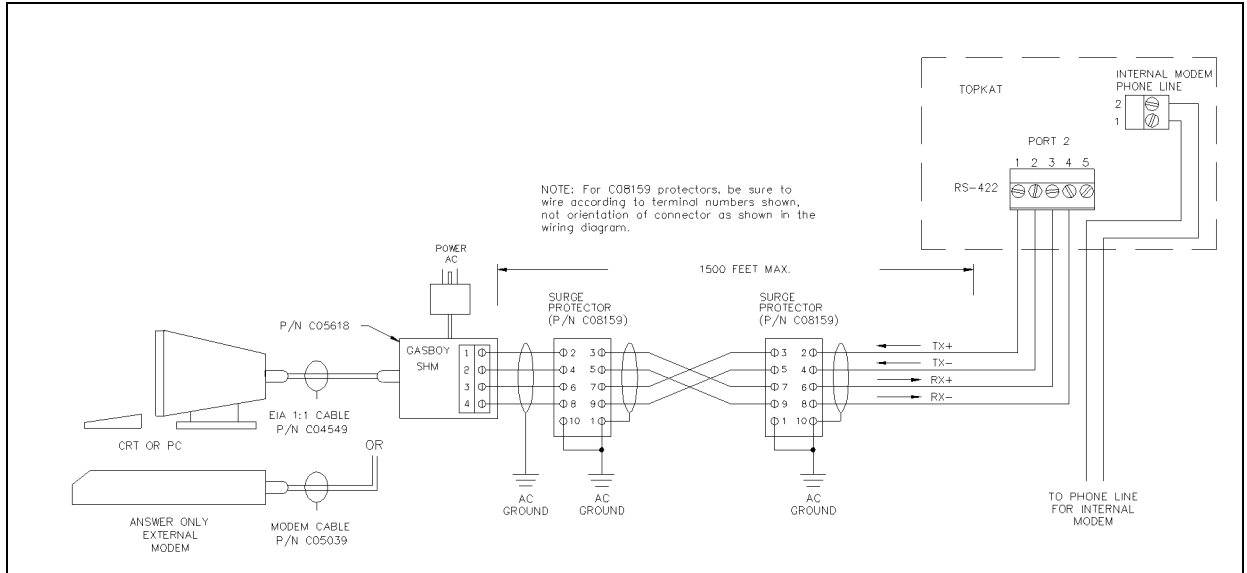

- Notes: 1) In the TopKAT, the green connector must be connected to P3 on the communication board for Port 2, and P5 for Port 3.
- 2) In cases where a TopKAT internal modem is used, Port 3 is not available for external communication wiring.
- 3) The K1 and K2 jumper for the port being used should be set to RS-422. Refer to "Terminal Block ID" on page 42 for the location of K1 and K2 jumpers.

Figure 7-27: Wiring Diagram: Internal Modem

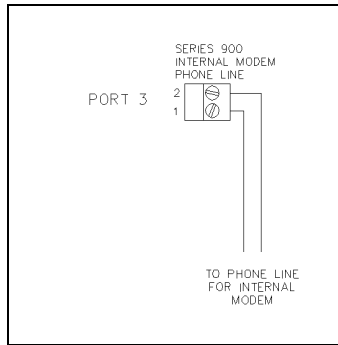

Notes: 1) In cases where a TopKAT internal modem is used, Port 3 is not available for external communication wiring.

2) The K2 jumper for Port 3 should be removed. Refer to “Terminal Block ID” on page 42 for the location of the K2 jumper.

Figure 7-28: Wiring Diagram: TopKAT Master/Satellite Communications Wiring

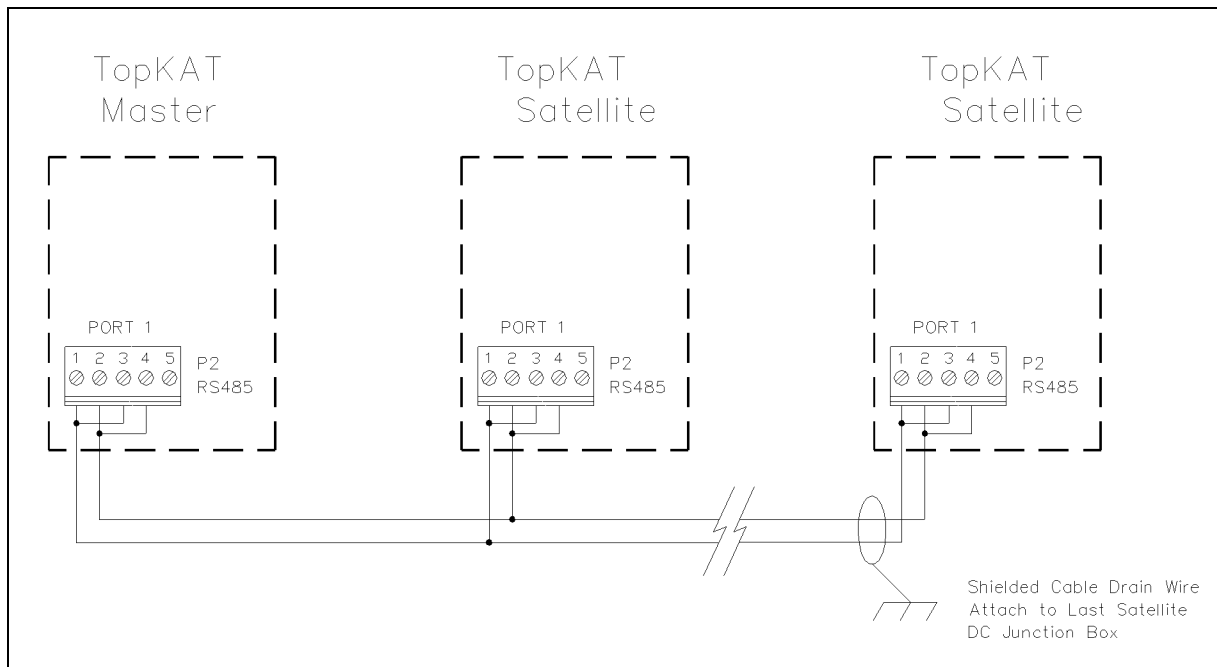
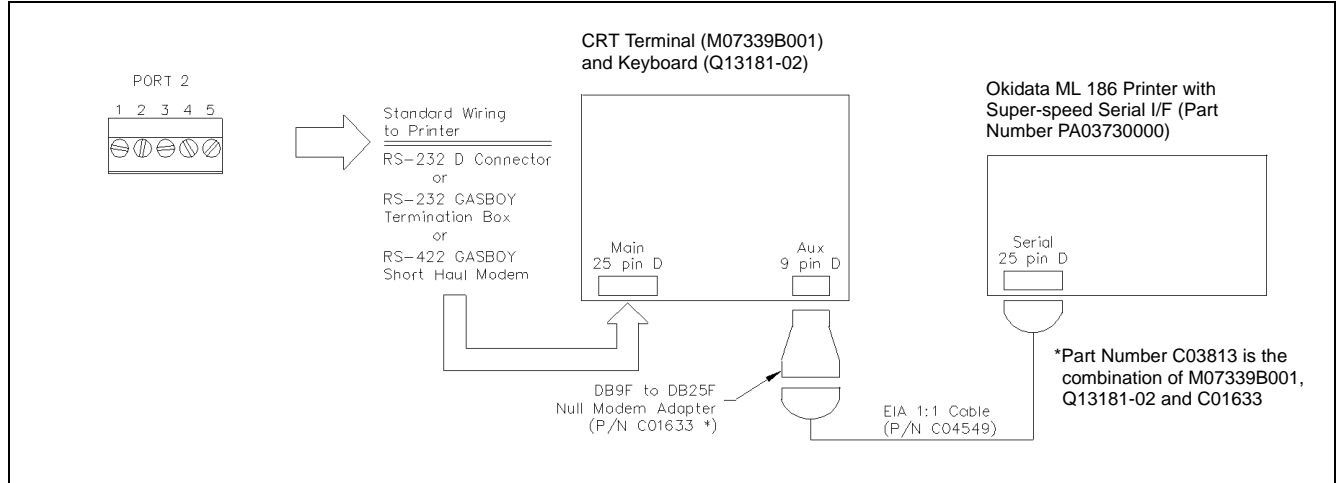

Figure 7-29: Wiring Diagram: CRT Terminal and Okidata Printer



Wiring for Modems

External Modems

The type of phone line required for communication via an external modem depends upon the type of modem used and the method of communication desired. Refer to the manual that is provided with the modem, for specific requirements.

Internal Modem

When the TopKAT internal modem is installed, Port 3 communication is routed through the modem in place of being wired at the DC Junction box. Jumper K2 should be removed. Refer to [“Terminal Block ID”](#) on [page 42](#) for location of jumpers K1 and K2. The phone line for the internal modem can be installed in the DC conduit. If you are installing it in the DC conduit, the cable must be two twisted-pair shielded cable as specified in [“Communication Requirements”](#) on [page 19](#) and the shield drain wire must be connected to the system AC ground. Check with your local phone company for proper installation of the phone line.

This page is intentionally left blank.

8 – Mechanical PCU Option

Description

The Mechanical PCU option for the TopKAT system allows the unit to control fueling and gather information from up to eight mechanical hose outlets (Four per PCU, with a maximum of two PCUs). The TopKAT system with Mechanical PCU configuration is mounted on top of a pedestal. PCUs can be mounted within the pedestal or wall-mounted.

- PCUs mounted within the pedestal require a large square pedestal. When using pedestal-mounted PCUs, all pump/dispenser wiring connections are made within the TopKAT system pedestal.
- Wall-mounted PCUs use a triangular pedestal. When using wall-mounted PCUs, all pump/dispenser wiring connections are made within the wall-mounted PCUs.

The TopKAT system with the Mechanical PCU option can also be used in a master/satellite configuration.

The mechanical PCU includes two solid-state relays and one manual override switch for each hose outlet, which control power to the fuel dispensing equipment (for the override switches to place the pump in MANUAL position, individual PCU power must be present). The TopKAT system can handle quantity pulsing rates of 1, 10, 100, 500, and 1000 per gallon measurement and 1, 10, 100 and 250 per liter measurement.

PCU Dimensions and Layouts

See the following figures for dimension and layout information:

- [Figure 8-1 on page 76](#)
- [Figure 8-2 on page 77](#)
- [Figure 8-3 on page 78](#)
- [Figure 8-4 on page 79](#)

Figure 8-1: Pedestal Dimensions - Pedestal-mounted PCU

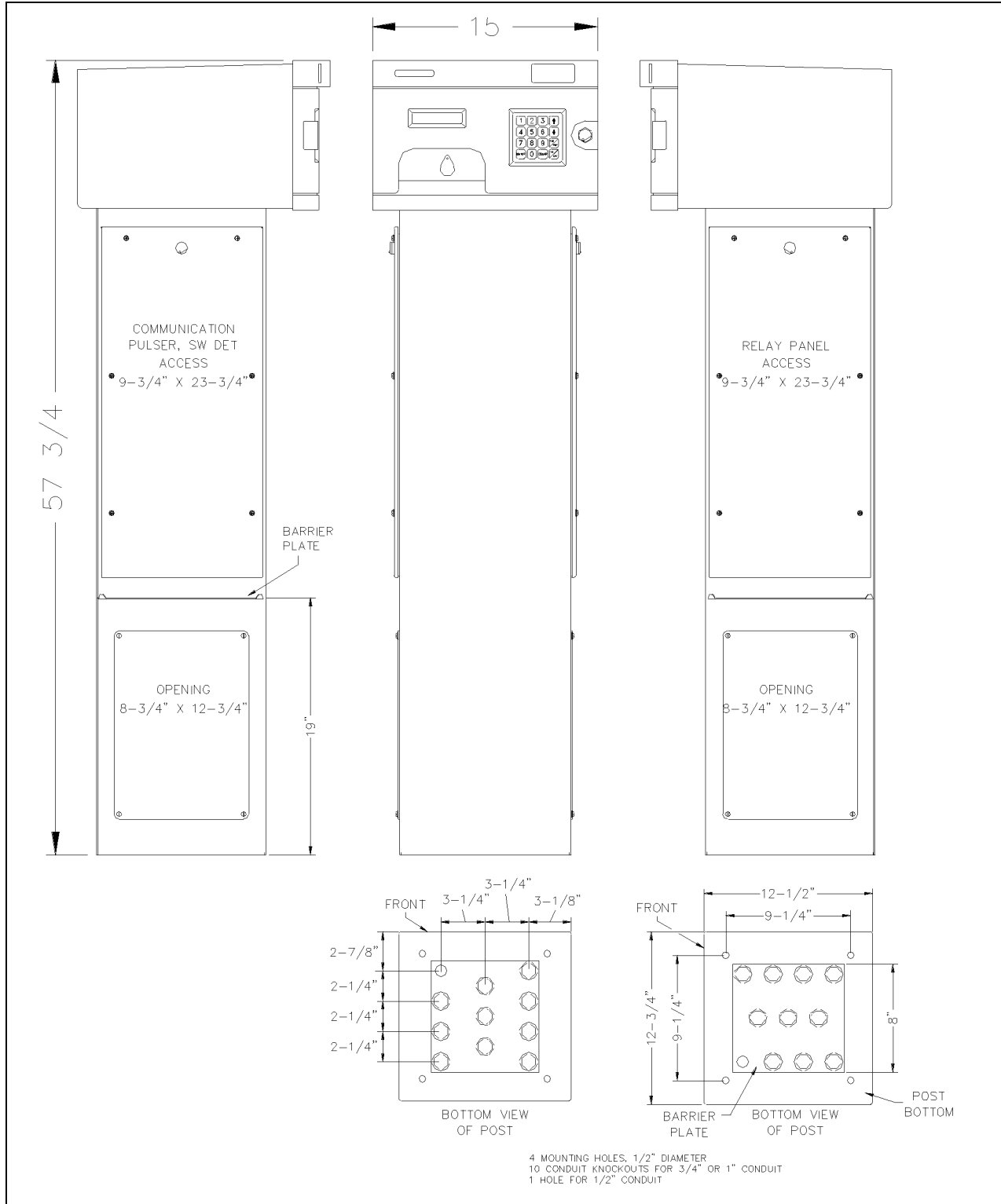

Figure 8-2: Wall-mount PCU Dimensions

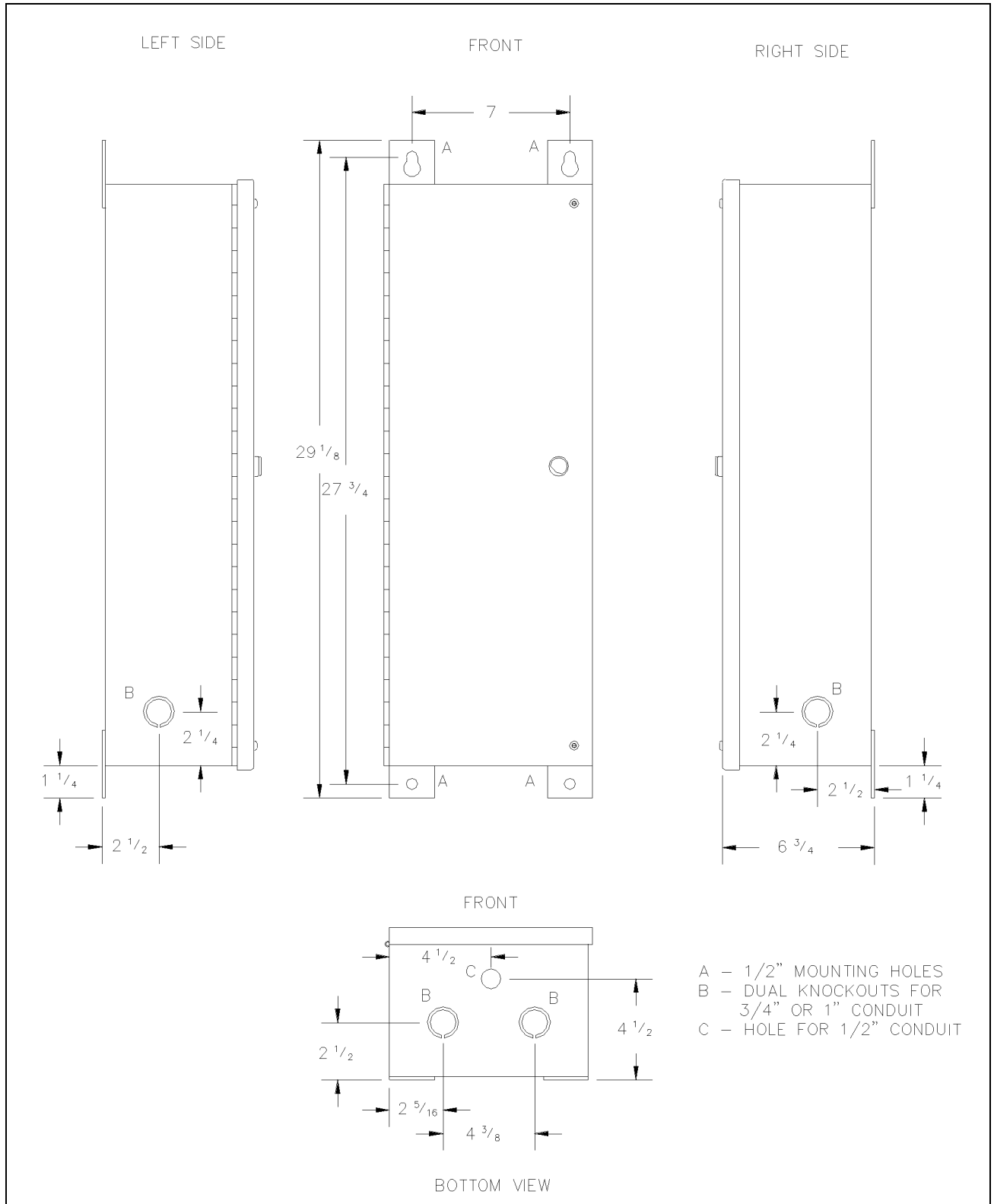

Figure 8-3: Conduit Layout - Pedestal PCU

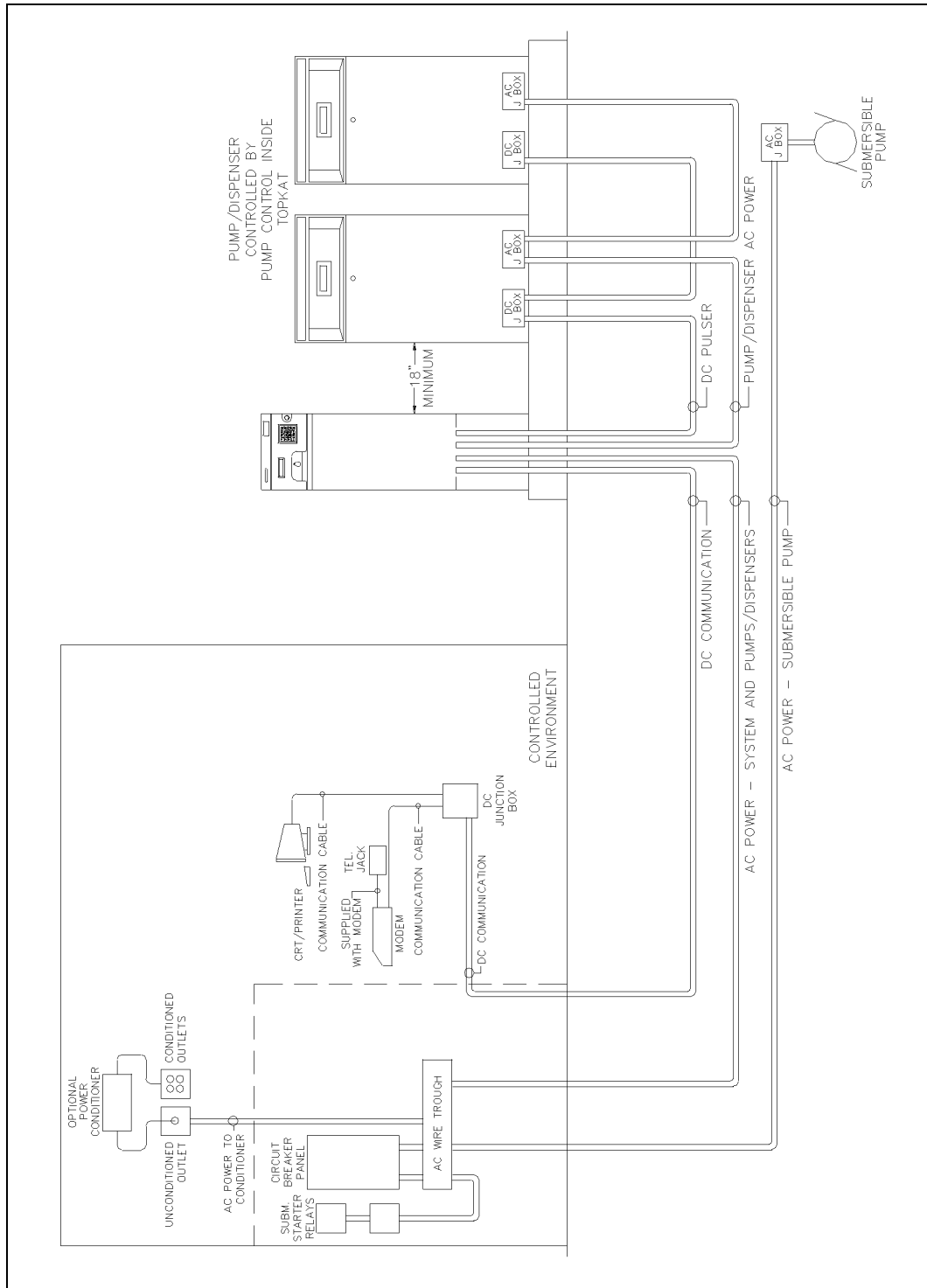
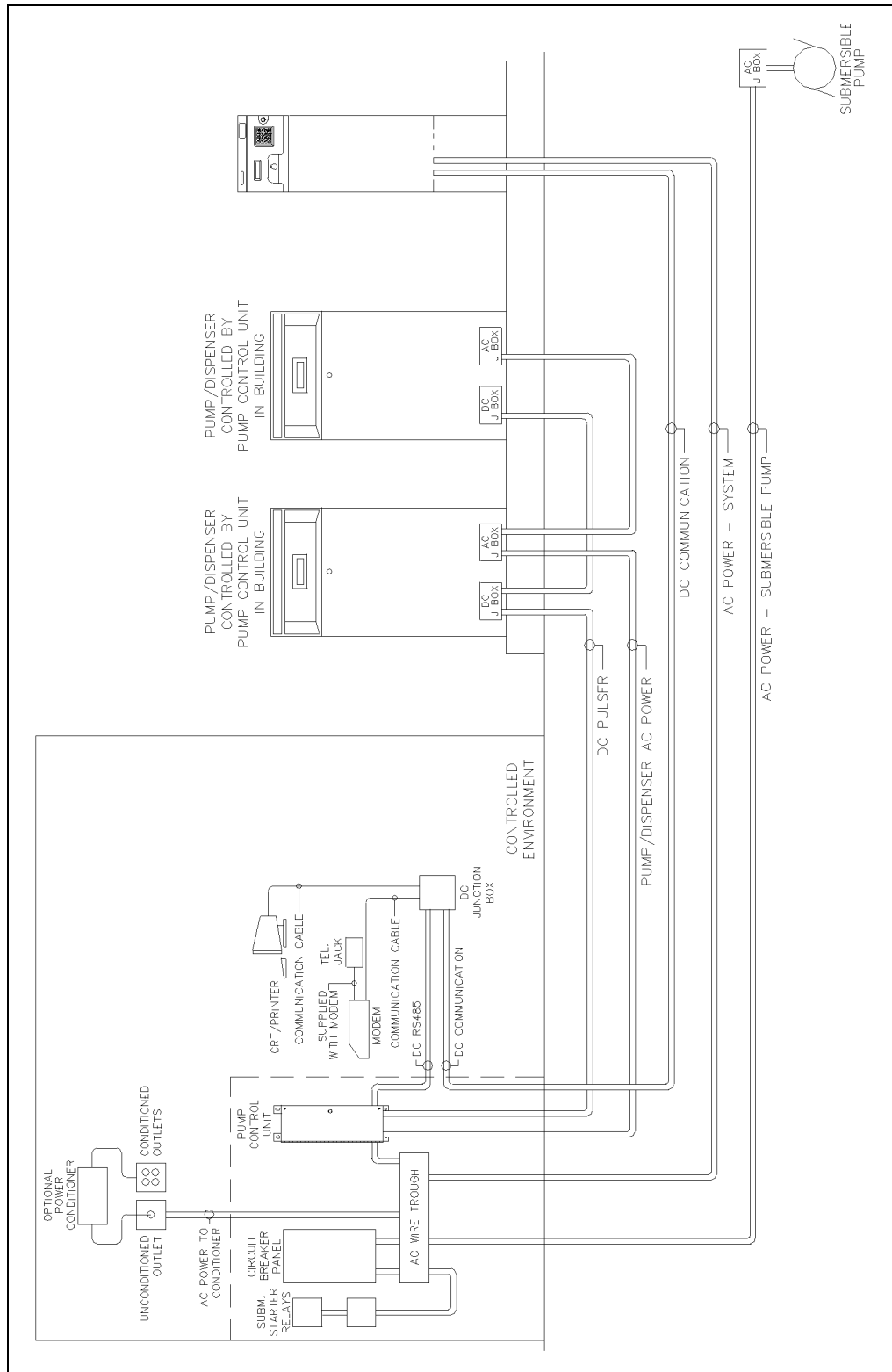

Figure 8-4: Conduit Layout - Wall-mounted PCU

Note: Refer to “General Installation” on page 11 for conduit, power requirements, and wire size considerations.



Terminal Block ID

To gain access to the inside of the TopKAT system, proceed as follows:

- 1 Unlock the rear door and open it completely.
- 2 Unscrew the two captive screws holding the hood in place.
- 3 Slide the hood toward the rear of the unit (about 1 inch) and lift it straight up.

See the following figures for Terminal Block ID information:

- [Figure 8-5 on page 81](#)
- [Figure 8-6 on page 82](#)
- [Figure 8-7 on page 83](#)

Figure 8-5 shows the mechanical PCU components. Refer to “Terminal Block ID” on page 24 for the TopKAT Comm Assembly.

Figure 8-5: Terminal Block ID: Standard Pedestal - Left Side

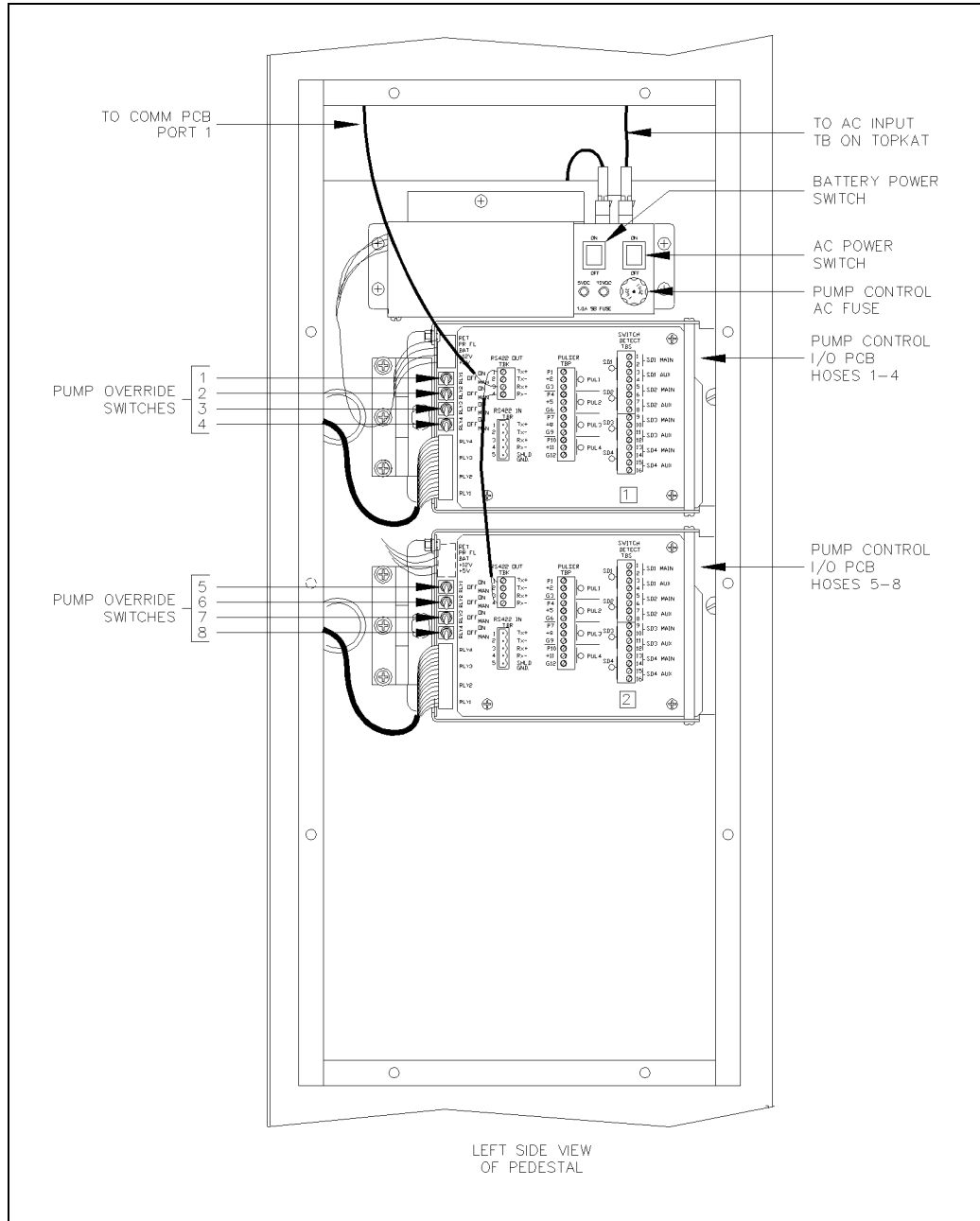

Figure 8-6: Terminal Block ID: Standard Pedestal - Right Side

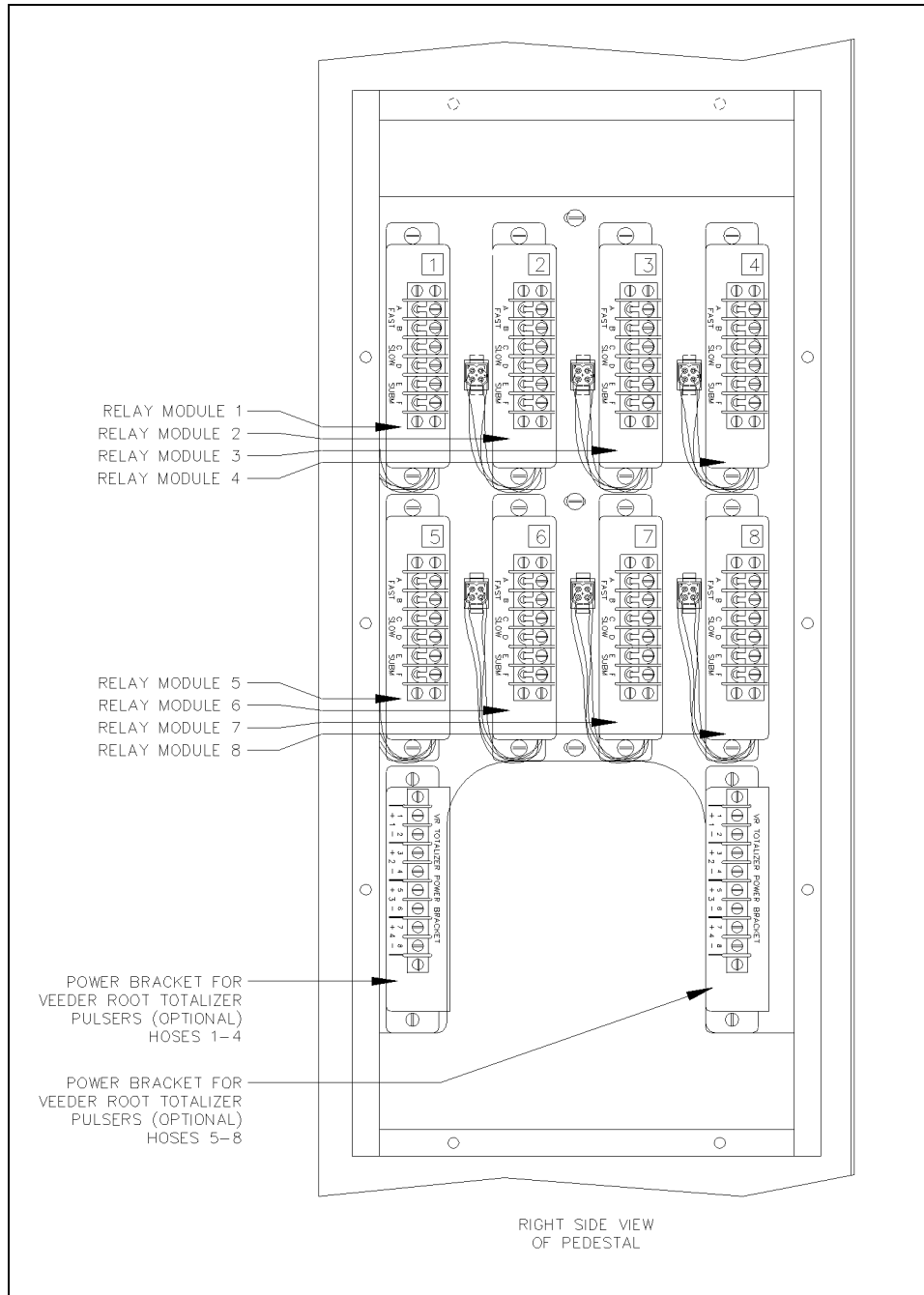
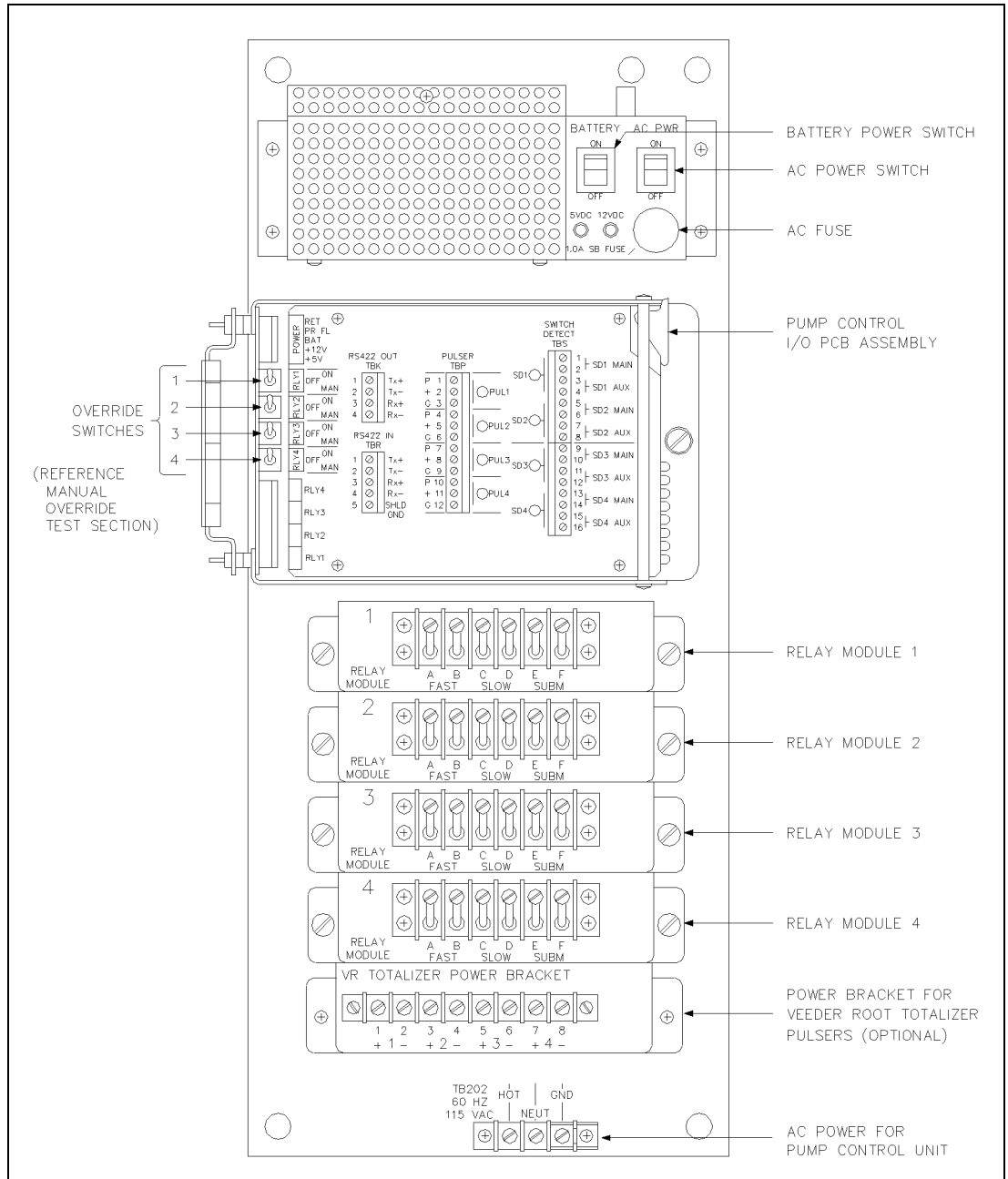

Figure 8-7: Terminal Block ID: Wall-mounted PCU



Pump Control EXPMUX CPU Board

- 1 Unlock and open the front door of the wall-mounted pump control unit or open the pedestal access.
- 2 Ensure that all override switches are in the AUTO position. See [Figure 8-8](#).
- 3 Ensure that the AC power and battery switches located in the upper right corner of the power supply are turned off (down).
- 4 Loosen the screw for the card cage section, and swing out the card cage.
- 5 Remove the pump control EXPMUX CPU board ([Figure 8-8](#)), located in the rear portion of the card cage, by pulling the top white tab.
- 6 Locate the K1 jumper patch and install the jumper. This jumper allows battery voltage to the RAM. It should be installed for normal operation and removed for storage to prevent battery discharge.

Figure 8-8: EXPMUX CPU Board

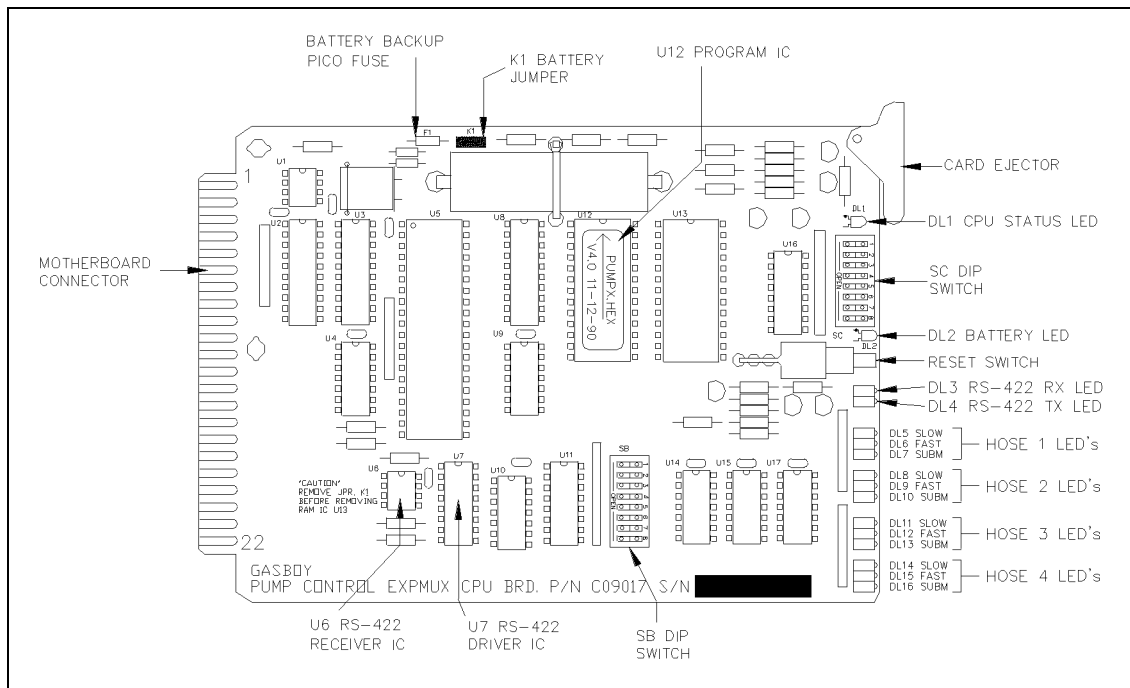

- 7 Verify if the pump control CPU board switch bank, **SB** (1 through 4), is set for the proper address.

An address must be set to identify the pump control unit when it is connected to the TopKAT system. This address is a unique identifier for multiple PCUs that are connected on the same RS-485 line. Addressing should start at 1 and continue sequentially through 16. The physical wiring order does not have to correspond with the address order, that is, the first unit on the RS-485 line does not have to be address 1.

Switches 1 through 4 denote the address. This is factory set and does not have to be corrected. The table below provides the switch settings for the address selections.

	SB-1	SB-2	SB-3	SB-4
Address	ADDR1	ADDR2	ADDR3	ADDR4
1	Closed	Closed	Closed	Closed
2	Open	Closed	Closed	Closed
3	Closed	Open	Closed	Closed
4	Open	Open	Closed	Closed
5	Closed	Closed	Open	Closed
6	Open	Closed	Open	Closed
7	Closed	Open	Open	Closed
8	Open	Open	Open	Closed
9	Closed	Closed	Closed	Open
10	Open	Closed	Closed	Open
11	Closed	Open	Closed	Open
12	Open	Open	Closed	Open
13	Closed	Closed	Open	Open
14	Open	Closed	Open	Open
15	Closed	Open	Open	Open
16	Open	Open	Open	Open

- 8 Switches SB-5 through SB-8 are not relevant to the operation of this unit and should be set to Closed.
- 9 The settings for switch bank **SC** (1 through 4) determine when the pump control unit begins counting pulses for a particular pump. When a switch is open, the PCU begins counting pulses when the corresponding pump is activated. When a switch is closed, as it should be for most configurations using mechanical pumps, the PCU does not count pulses for the corresponding pump until the mechanical reset has completed. The table below provides the switch settings for SC-1 through SC-4.

Switch	Function	
SC-1	Mode pump 1	Open = Normal, Closed = Reset Complete
SC-2	Mode pump 2	Open = Normal, Closed = Reset Complete
SC-3	Mode pump 3	Open = Normal, Closed = Reset Complete
SC-4	Mode pump 4	Open = Normal, Closed = Reset Complete

- 10** In switch bank **SC**, between 5 through 8, only switch 6 and 8 are active. Switch **SC-6** is the Deadman Timer Switch. If enabled, the pump control unit must be polled at least every 15 seconds by the TopKAT. If it fails to sense a poll at that time, it turns off all relays. If Reset Complete Mode is used on any pump on a particular PCU, the deadman timer should be disabled. Switch **SC-8** enables the test mode allowing the basic PCU functions to be tested without the use of a site controller.

The table below gives the switch settings for **SC-5** through **SC-8**.

Switch	Function	
SC-5		No function in on-line mode
SC-6	DEAD	Open = deadman timer enabled
SC-7		No function in on-line mode
SC-8	TEST	Open = Test mode, Closed = On-line mode

- 11** Reinstall the EXPMUX Pump Control CPU board.

Pump Control I/O PCB

The Pump Control I/O PCB, shown in [Figure 8-9](#), consists of two parts, the PCB and a cover plate. To set the jumpers and switches on the I/O PCB, you must remove all the connectors and the cover plate.

Figure 8-9: Pump Control I/O Cover Plate and PCB

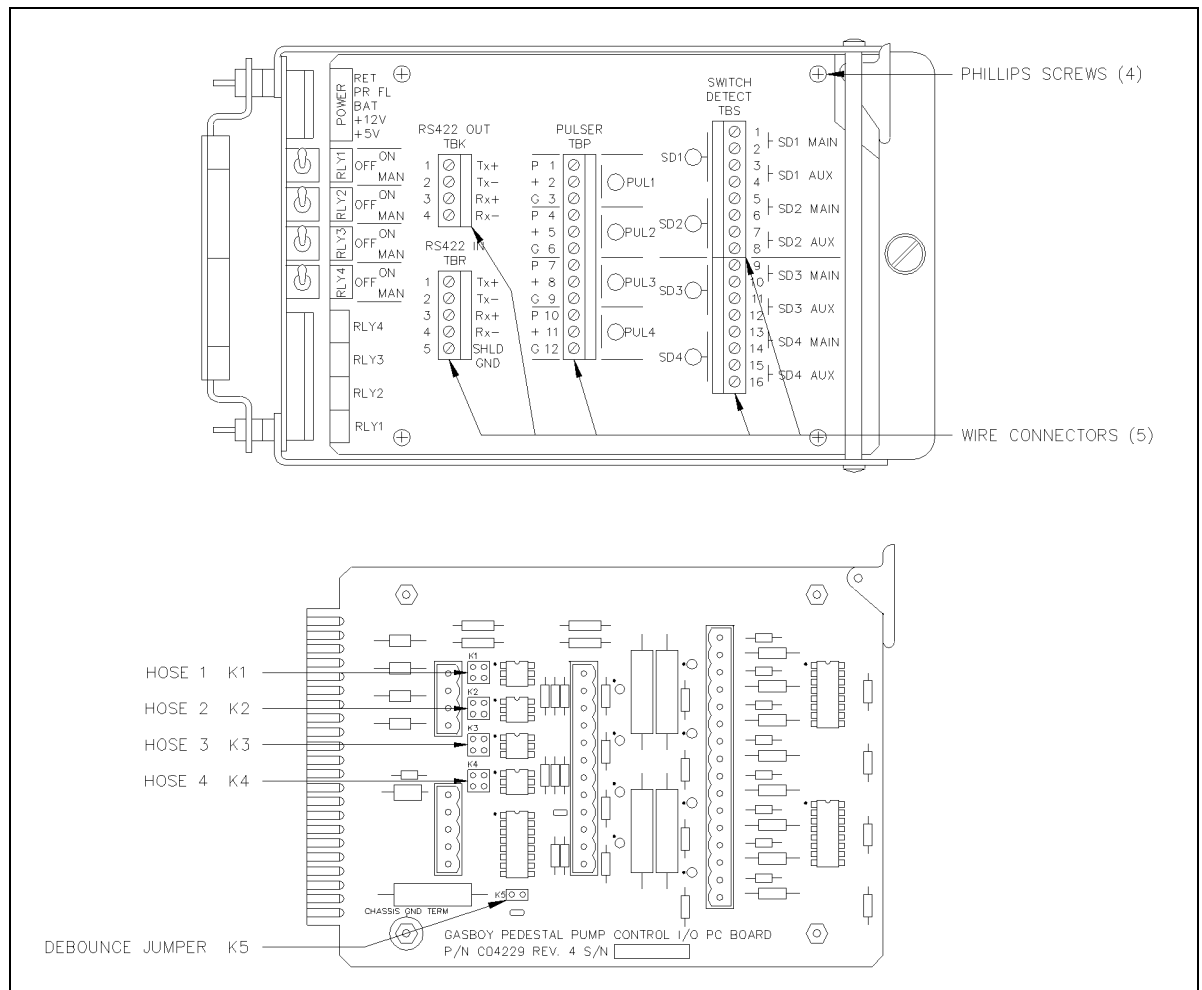



- 1 Remove the five green connectors from the front of the Pump Control I/O board.
- 2 Remove the board from the card cage in the same manner as the EXPMUX Pump Control CPU board (see step 5 below [“Pump Control EXPMUX CPU Board”](#) on page 84).
- 3 Remove the four Phillips® screws securing the cover plate to the PCB and remove the cover plate.



- 4 Pulse Connection: Verify if the **K1** through **K4** jumpers (pulse type jumpers) match the Type pulser being used for each pump position. Use the following table to determine your settings.

CAUTION

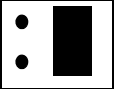
K1 to K4 jumpers must be set in the configurations shown below before turning on power to the PCU or damage to the system components may occur.

Jumper	Pin	Function	Voltage	
VR Reed Switch Pulser, 1871 Series				
 K1	1	P Pulser signal input (sink)	12 VDC square wave signal when pulsing	
		+	No connection	
	2	G DC ground for pulser	DC ground	
VR Electronic Pulser, 7671 Series				
 K1	1	P Pulser signal input (sink)	12 VDC square wave signal when pulsing	
		+	+12 VDC supply voltage for pulser	+12 VDC
	2	G DC ground for pulser	DC ground	
VR Totalizer Pulser, 7874 Series				
 K1	1	P Pulser signal input (sink)	Square wave signal when pulsing	
		+	Voltage for opto-isolator from pulser	Voltage level of pulser
	2	G DC ground for pulser	DC ground	

- 5 Debounce Configuration: Verify if the **K5** jumper (debounce) is set properly as per the following table. The K5 jumper should remain jumpered for all Reed Switch Quantity pulsers and unjumpered for all Electronic and Money pulsers.

Jumper	Speed	Function
K5  Jumpered	Slow	10:1 quantity pulsers
K5  Open	Fast	10:1 money pulsers All electronic pulsers

- 6 Replace the cover plate on the pump control I/O board and reinstall the board into the card cage.
- 7 Replace the five green connectors into the proper sockets on the front of the Pump Control I/O board ([Figure 8-9](#) on [page 87](#)).
- 8 Repeat all steps for both the EXPMUX Pump Control CPU and Pump Control I/O PCBs for each PCU.

System Pump and Dispenser Wiring

Wiring Precautions

WARNING

To reduce the risk of electrical shock when servicing, turn off all power to the pump/dispenser. In submersible pump applications, turn off all power to the submersible pump and any other dispensers which use that submersible pump. AC power can feed back into a shut off dispenser when dispensers share a common submersible pump or starter relay.

AVERTISSEMENT

Pour réduire le risque de choc électrique lors de l'entretien/révision, coupez totalement le courant à la pompe/distributeur. Dans les applications de pompe immerisible, coupez totalement le courant à la pompe immerisible et tous autres distributeurs qui utilisent la pompe immerisible. Le courant alternatif peut alimenter de nouveau un distributeur à l'arrêt quand les distributeurs partagent une pompe immerisible commune ou un relais de démarrage.

The quality of the electrical installation is a major factor in maintaining proper safety levels and providing trouble-free operation of your Gasboy pump/dispenser. To ensure a quality installation, follow these rules:

- All wiring must be installed and used in accordance with local building/fire codes, all Federal, State, and Local codes, the National Electrical Code (NFPA 70), NFPA 30, and the Automotive and Marine Service Station Code (NFPA 30A) codes and regulations. Canadian users must also comply with the Canadian Electrical Code.
- Use approved conduit and insulated gasoline and oil resistant copper wiring of the proper size.
- Wire connections must be tightly spliced and secured with a wire nut. Close off the open end of the wire nut with electrical tape.
- Install an emergency power cutoff. In addition to circuit breaker requirements of NFPA 70, NFPA 30, NFPA 30A and the Canadian Electrical Code (Canadian users only), a single control which simultaneously removes AC power from all site dispensing equipment is recommended. This control must be readily accessible, clearly labeled, and in accordance with local codes.

In order to provide the highest level of safety to you, your employees, and customers, all employees must be trained as to the location of the power supply and the procedure for turning off power to the entire system.

Control Lines for Mechanical Pumps/Dispensers

Descriptions of the control lines are provided to familiarize the installer with the control inputs and outputs that are used to control a mechanical pump/dispenser. Reading these descriptions will give the installer a better working knowledge of the system and aid in planning the site wiring.

Grounding

To ensure proper operation of the equipment and provide the necessary safety factors, this unit must be grounded. A ground wire (preferably green) must be connected between the ground wire of the system and the main electrical service panel. One earth ground connection is required for each unit. A ground rod must be installed at the main electrical panel in accordance with the National Electrical Code. This ground rod must be a solid, corrosion-resistant conductor. It should be properly tied into the ground bus strip of the panel. We recommend the neutral and ground bus strips be bonded together (unless prohibited by local codes).

Reset Motor Feed

This is a 115 VAC input which is supplied through the pump handle switch to activate the reset motor. This line should be switched through the TopKAT system and should only be on when the pump/dispenser is authorized or in manual mode. Without power supplied to this line, the pump/dispenser will not reset when the pump handle is turned on. Two feed lines are provided for twins. This feed is also connected to the input of one of the internal switches of the electric reset. When the reset finishes its cycle, the 115 VAC input to the switch will be passed through as an output, causing the solenoid valve (optional in some models) to open and the Reset Complete line to indicate 115 VAC.

Pump Motor Feed

This is a 115 VAC input which is supplied to the input side of one of the internal switches of the electric reset. This line should be switched through the TopKAT system and should only be on when the pump/dispenser is authorized or in the Manual mode. When the reset finishes its cycle, the 115 VAC input to the switch is passed through as an output causing the pump motor to receive power and begin fueling. Without power to this line, the unit will reset, but will be unable to fuel. Two feed lines are provided in twins, which contain two motors. The gauge of this wire (and its neutral wire) should be determined according to the size of the motor, the voltage at which the motor will be powered (115 VAC or 230 VAC), and the distance from the breaker panel to the pump. It is possible to combine the pump motor feeds for twins and supply them from one breaker. However, the gauge of the wire needs to be adjusted to handle the load of two motors.

Note: 230 VAC is developed across a motor when the other leg of the motor is connected to a Phase 2 Feed.

Neutral Feed

This is the AC current return line to the breaker panel for all attached devices (pump motor, reset motor, solenoid valves). The gauge of this wire must be equal to that of the pump motor feed (suction pumps) or submersible feed (dispensers).

Submersible Feed, Submersible Drive

This is a 115 VAC input which is supplied to the input side of one of the internal switches of the electric reset. This line should be switched through the TopKAT system and only be on when the pump/dispenser is authorized or in manual mode. When the reset finishes its cycle, the 115 VAC input to the switch is passed through as an output (submersible drive) to drive a starter relay or to directly drive a submersible motor up to 3/4 HP at 115 VAC or 1-1/2 HP at 230 VAC. Any submersible motor exceeding this limitation must use a starter relay.

Note: 230 VAC is developed across a motor when the other leg of the motor is connected to a Phase 2 Feed.

Reset Complete (Switch Detect)

This is a 115 VAC output which is used to indicate if the reset is complete and the pump/dispenser is ready to dispense the product. Two lines are provided for twins. This line should only be used when monitoring of the pump/dispenser is desired (such as when used with a fuel management system). This line must be capped when not in use.

Light Feed

This is a 115 VAC input required to power optional fluorescent lights that may be available in a pump/dispenser. In a site configuration using multiple dispensers (or pumps), the power for the lights of up to eight units can be supplied by one breaker. The light feed is not controlled by the TopKAT system.

Light Neutral

This is a return line for AC current from the lights to the breaker panel.

Phase 2 Feed

This is a hot feed which is the opposite phase of the pump motor feed. This line and the pump motor feed are used for 230 VAC motor applications.

Pulser - Mechanical Pump

This supplies a DC output which is provided to indicate the quantity dispensed.

Wiring Diagrams: Pulsers, Pumps, Dispensers

Mechanical PCU Option wiring diagrams are as follows:

- [Figure 8-10: Wiring Diagram: Pulsers on page 93](#)
- [Figure 8-11: Wiring Diagram: Single Suction Pump, Veeder-Root Reset on page 95](#)
- [Figure 8-12: Wiring Diagram: Twin Suction Pump, Veeder-Root Reset on page 96](#)
- [Figure 8-13: Wiring Diagram: Twin Suction Pump, Single Motor, Veeder-Root Reset on page 97](#)
- [Figure 8-14: Wiring Diagram: Single Remote Dispenser, Veeder-Root Reset on page 98](#)
- [Figure 8-15: Wiring Diagram: Twin Remote Dispenser, Veeder-Root Reset on page 99](#)
- [Figure 8-16: Wiring Diagram: Single Suction Pump, Gasboy Reset on page 100](#)
- [Figure 8-17: Wiring Diagram: Twin Suction Pump, Gasboy Reset on page 101](#)
- [Figure 8-18: Wiring Diagram: Twin Suction Pump, Single Motor, Gasboy Reset on page 102](#)
- [Figure 8-19: Wiring Diagram: Single Remote Dispenser, Gasboy Reset on page 103](#)
- [Figure 8-20: Wiring Diagram: Twin Remote Dispenser, Gasboy Reset on page 104](#)

Figure 8-10: Wiring Diagram: Pulsers

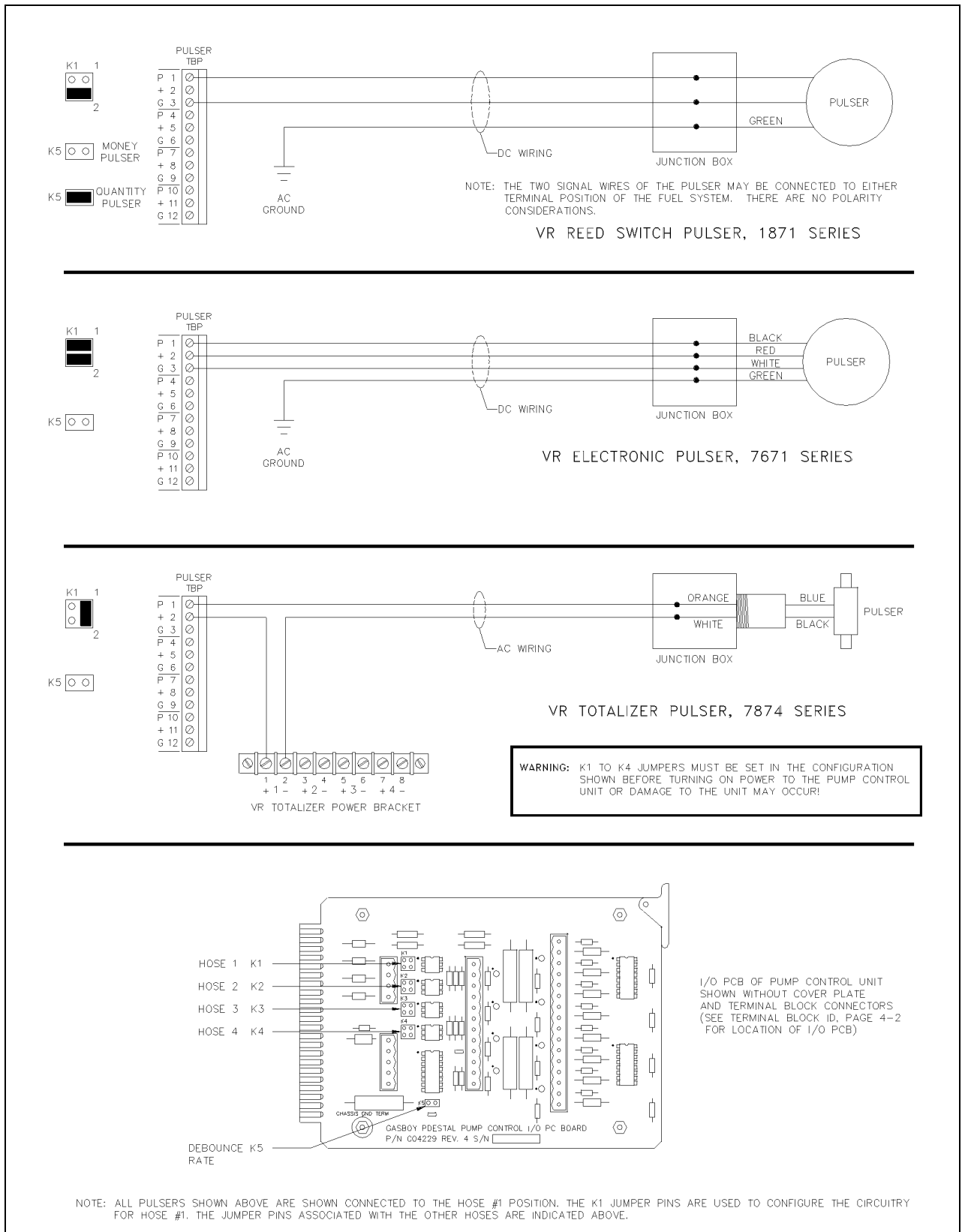

Pulser Wiring Notes

Notes: 1) All the pulsers shown above are connected to Hose 1.

2) Jumpers on the Pump Control PCB must be properly jumpered according to the pulser type. This should be done by the person performing the start-up. Power to the system must not be turned on prior to this setup.

3) Refer to “[Conduit Layout/Installation Specifications](#)” on [page 14](#) for detailed system installation specifications.

4) When installed in a separate DC conduit, 18 AWG wires are required for installation. Although it is recommended that DC pulser wires be run in a separate conduit away from AC wires, they can be combined in the same conduit with AC wires providing UL-listed cable with the following specifications is used:

- Conductor: 18 AWG stranded wire. Number of conductors to be determined by pulser*
- Shield: Foil-wrapped 100% coverage and/or tinned copper braid 90% coverage*
- Drain Wire: Stranded, tinned copper, 20 AWG or larger/or braided shield*
- Voltage Rating: Maximum operating voltage of 600 V*
- Environmental: Gas- and oil-resistant; suitable for wet or dry locations.*

Gasboy can supply Belden 1063A (part number C09655) which is a UL-listed, 4-conductor cable that meets the requirements listed above.

Note: Belden 1063A is UL-listed but not CSA-listed.

Figure 8-11: Wiring Diagram: Single Suction Pump, Veeder-Root Reset

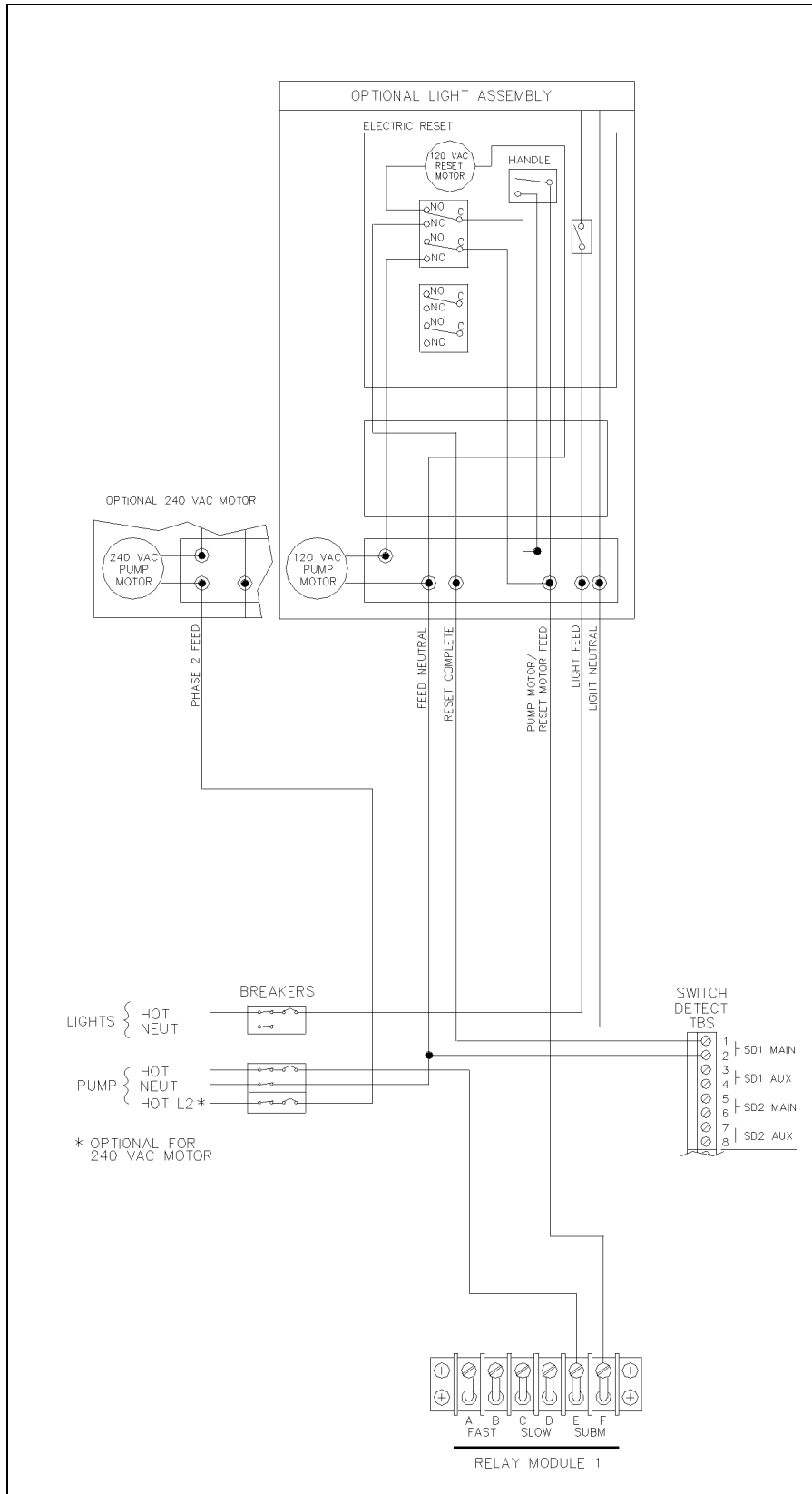

Figure 8-12: Wiring Diagram: Twin Suction Pump, Veeder-Root Reset

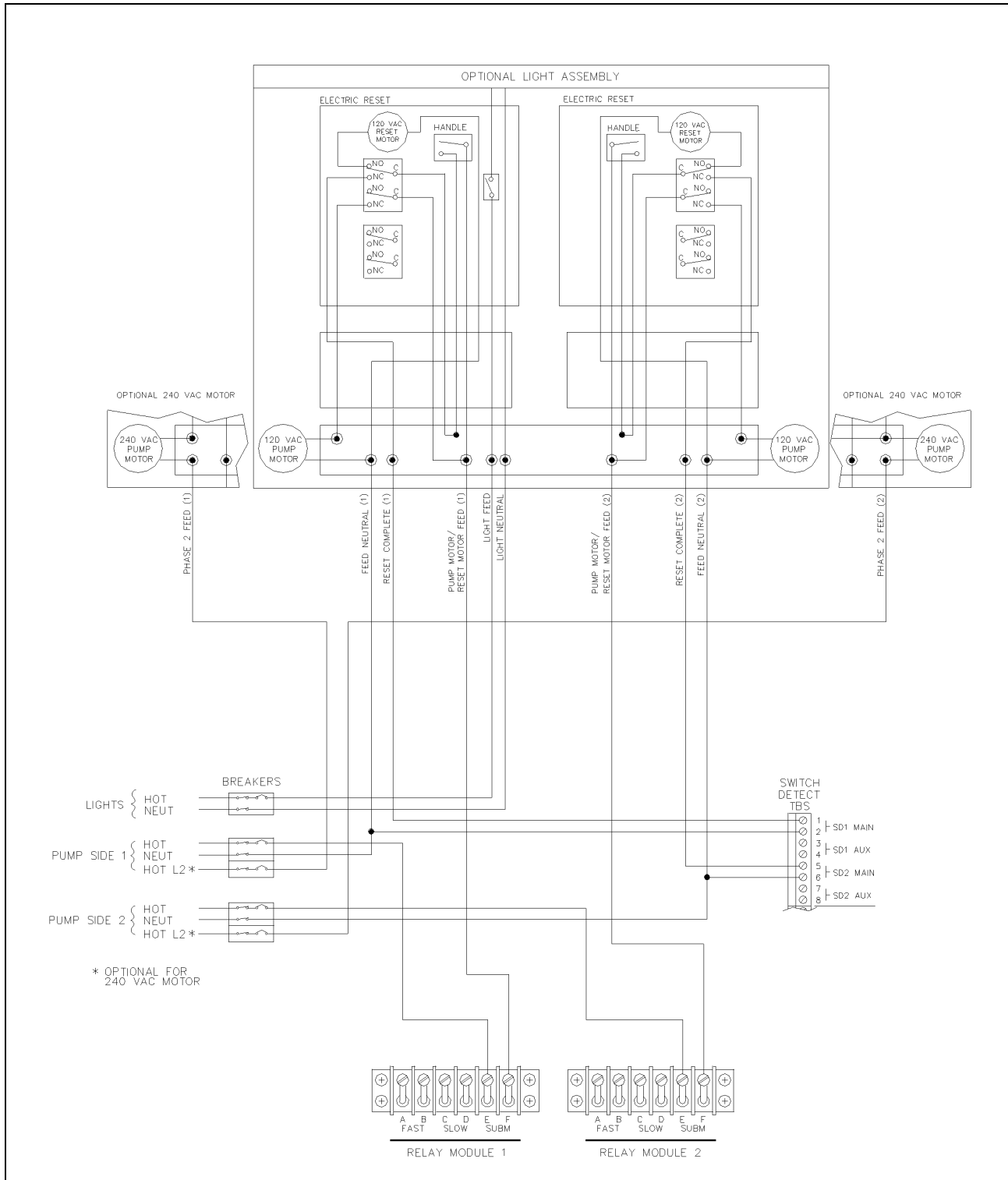

Figure 8-13: Wiring Diagram: Twin Suction Pump, Single Motor, Veeder-Root Reset

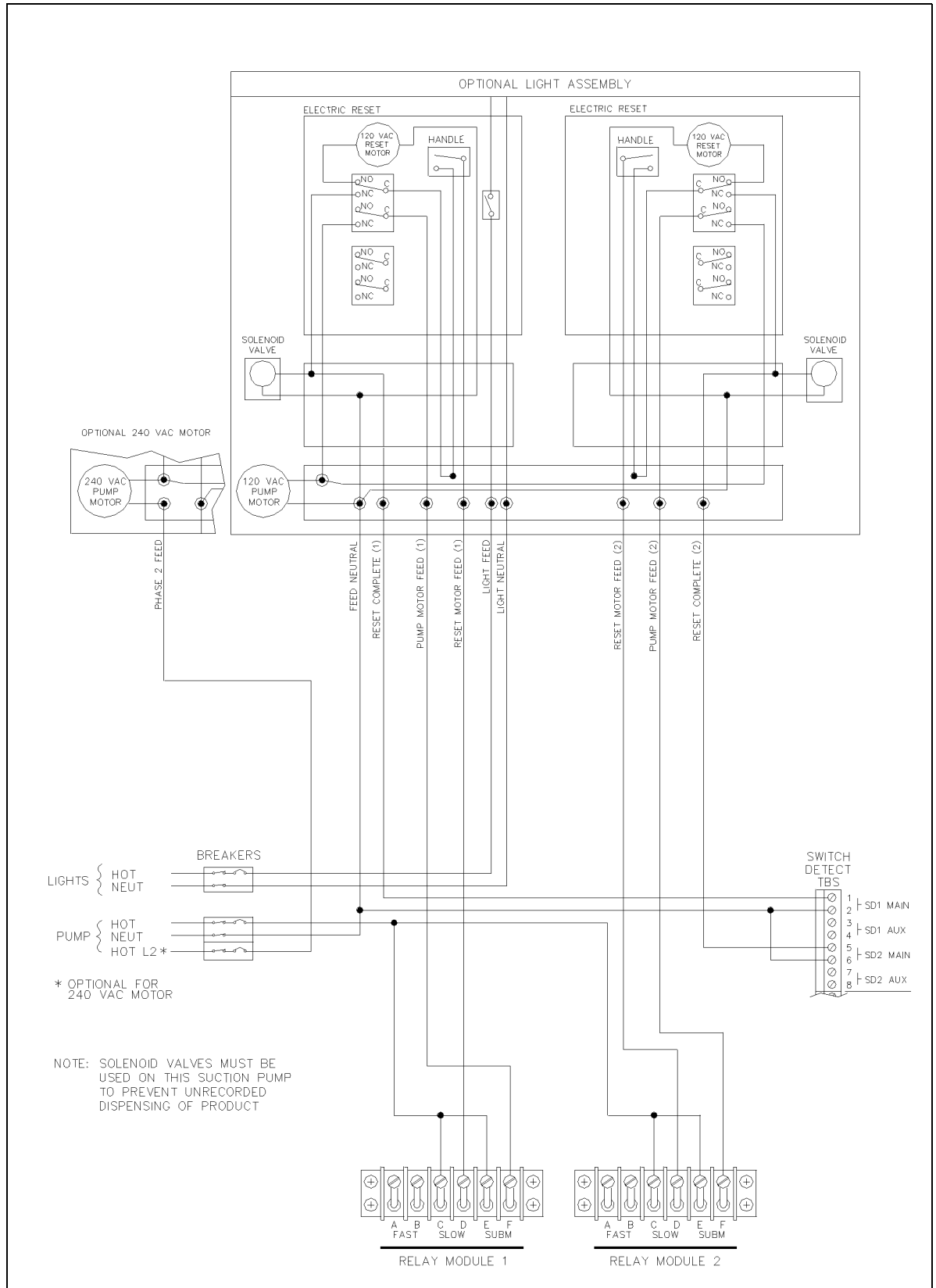

Figure 8-14: Wiring Diagram: Single Remote Dispenser, Veeder-Root Reset

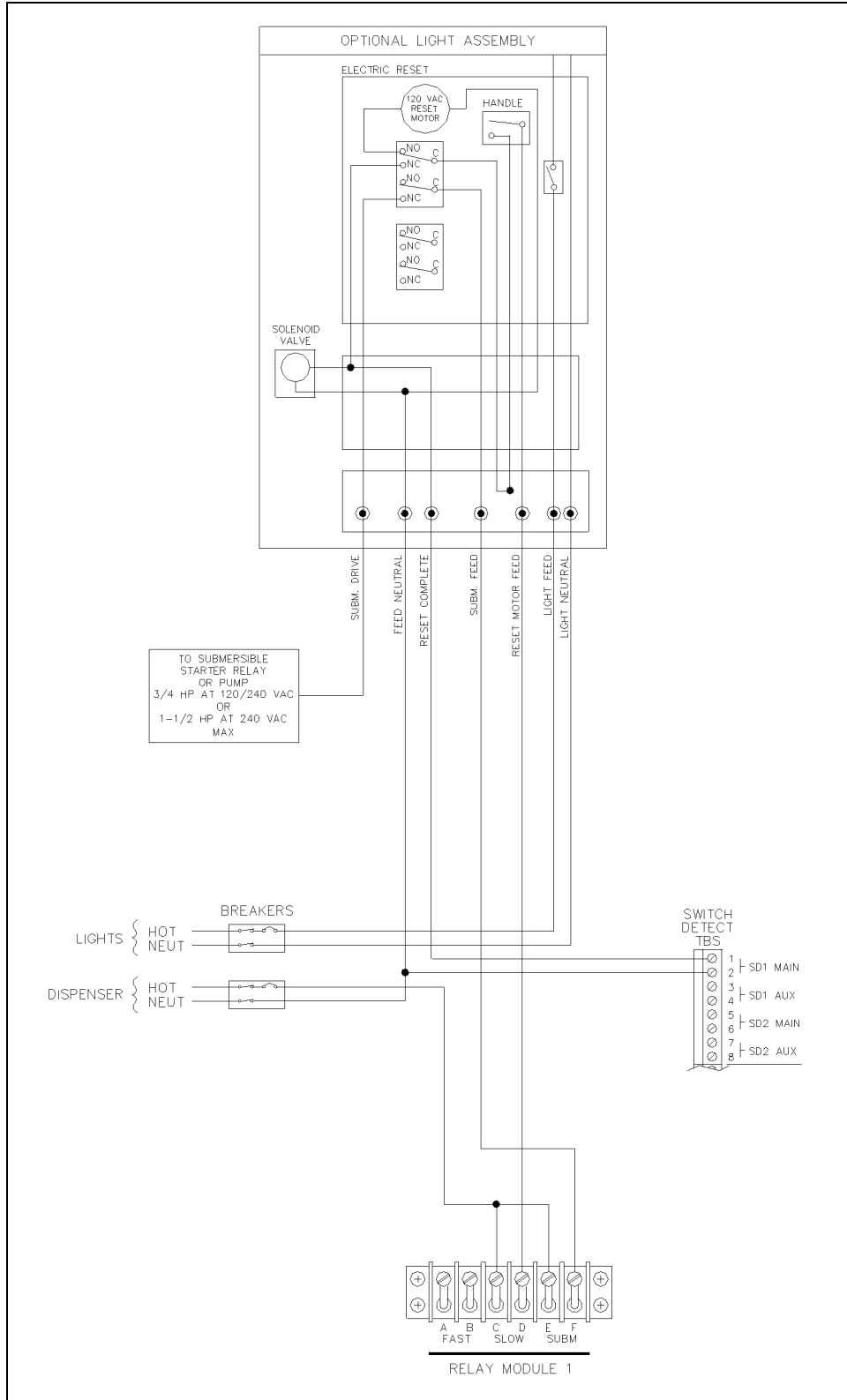

Figure 8-15: Wiring Diagram: Twin Remote Dispenser, Veeder-Root Reset

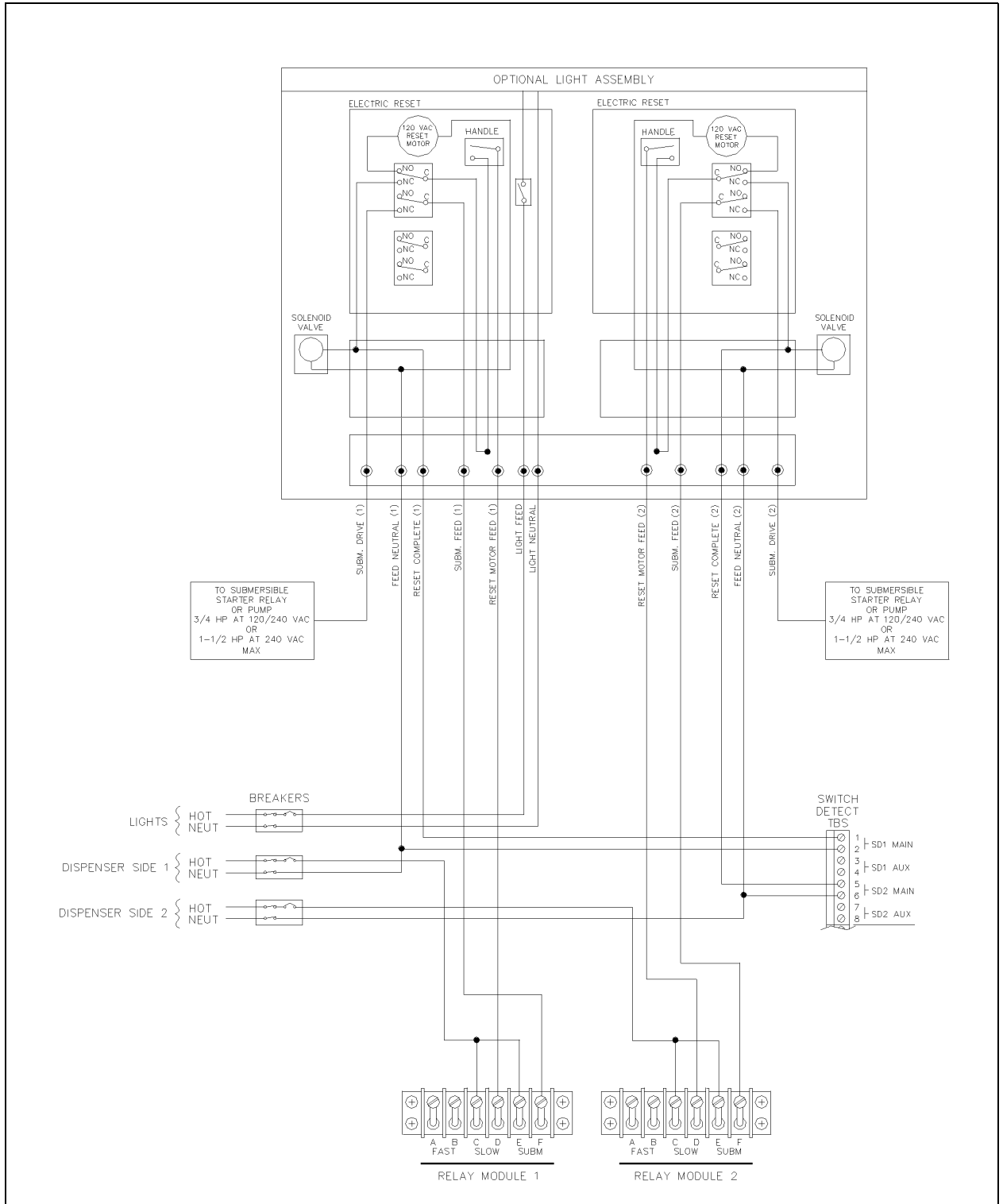

Figure 8-16: Wiring Diagram: Single Suction Pump, Gasboy Reset

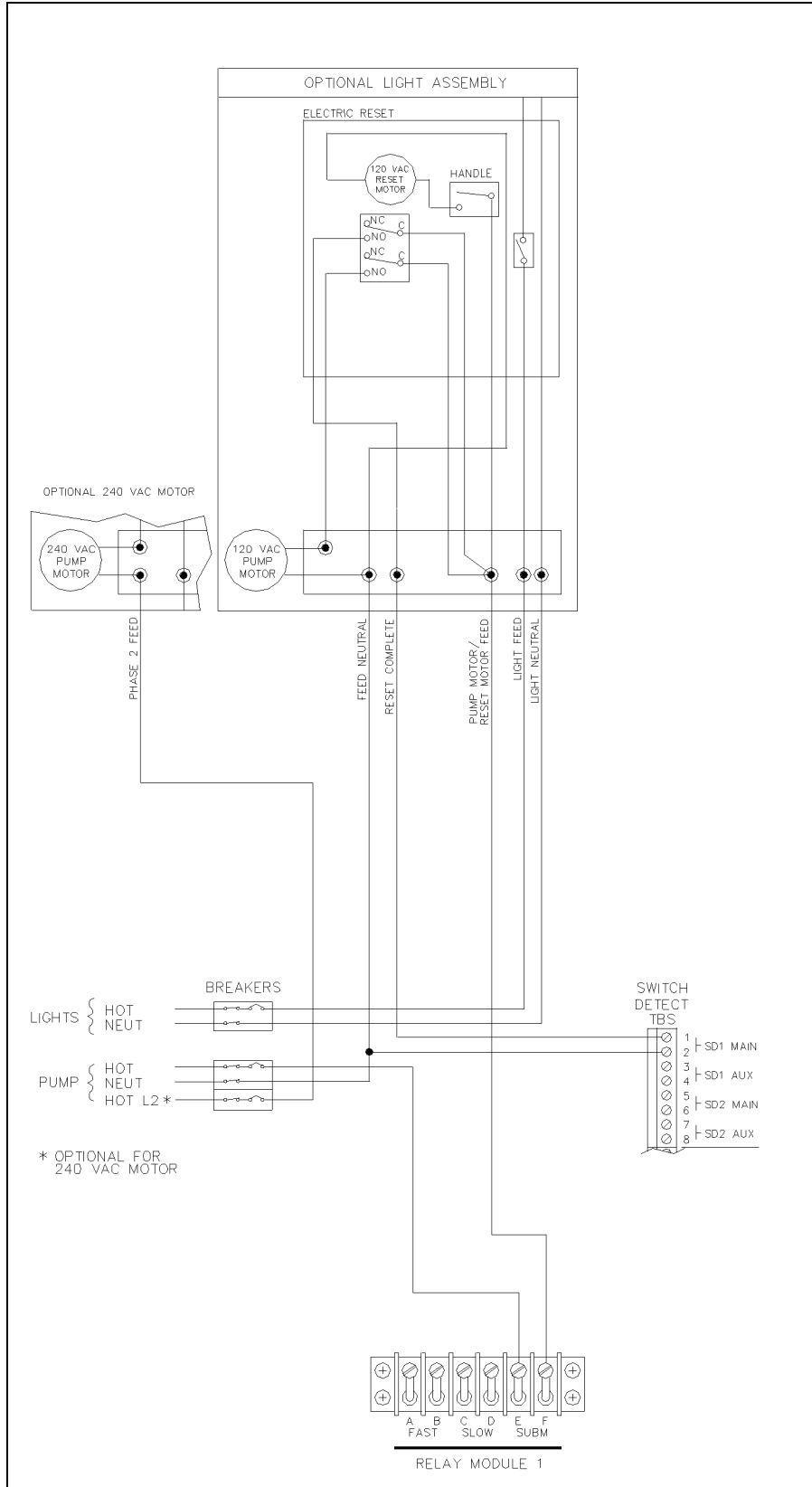

Figure 8-17: Wiring Diagram: Twin Suction Pump, Gasboy Reset

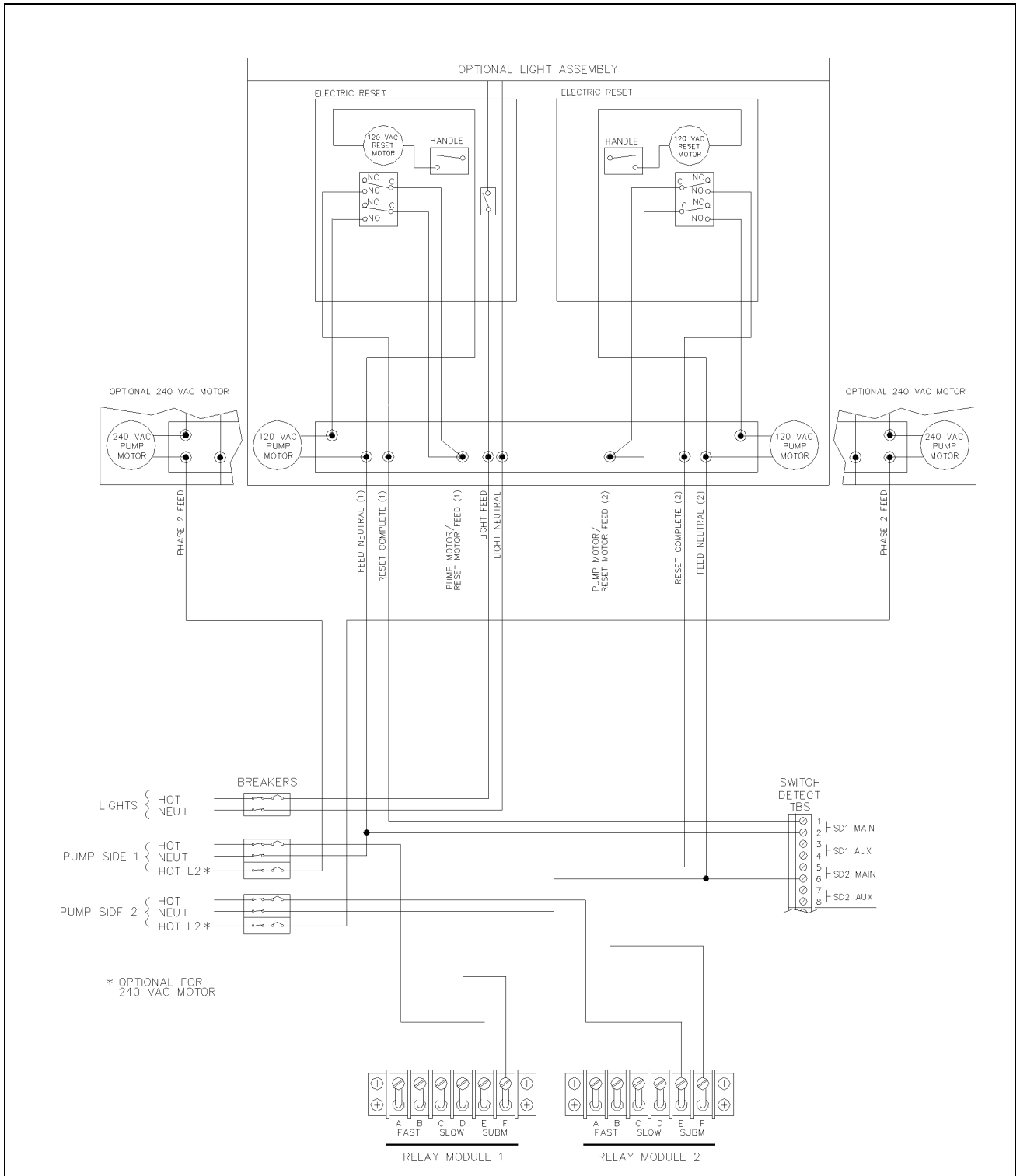

Figure 8-18: Wiring Diagram: Twin Suction Pump, Single Motor, Gasboy Reset

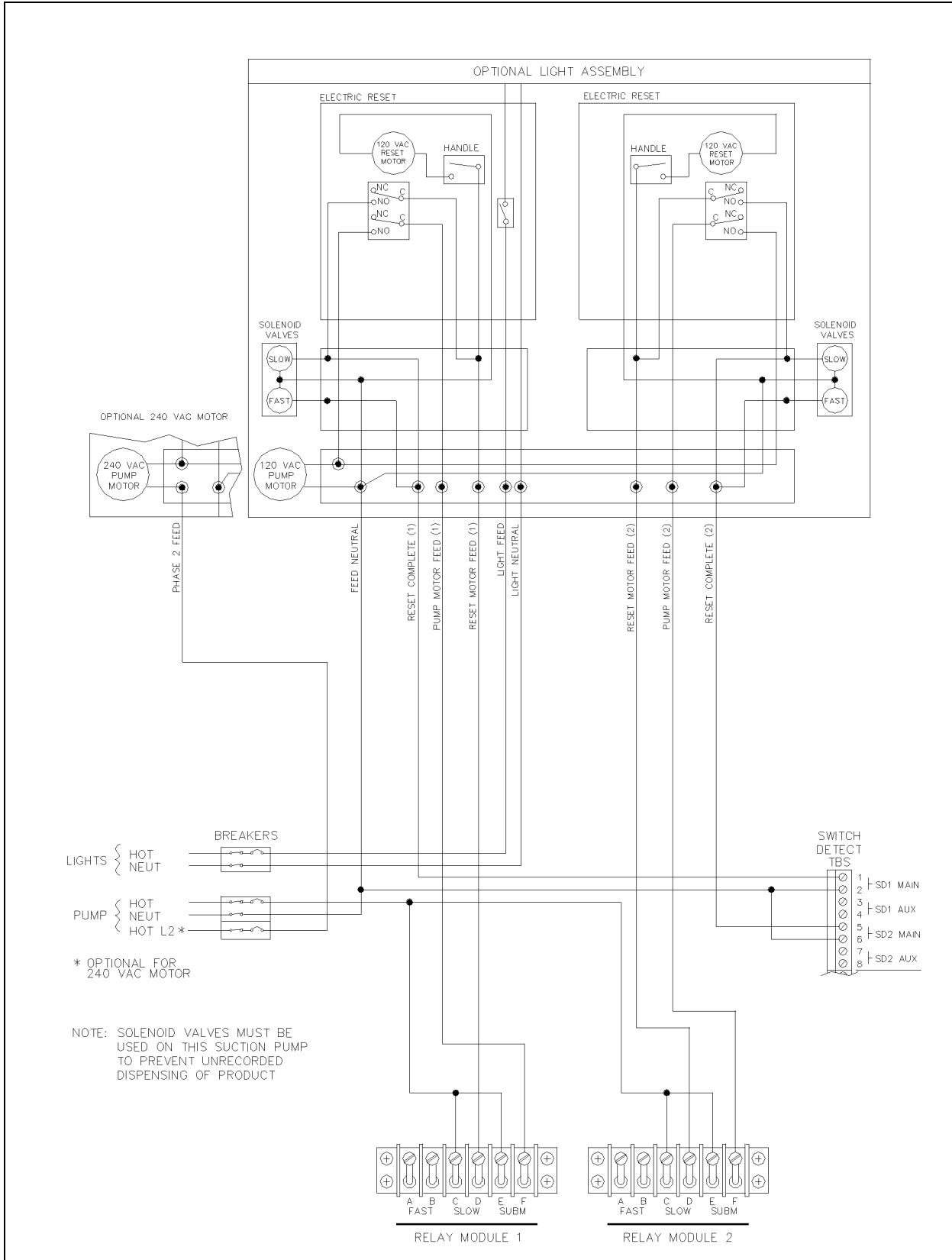

Figure 8-19: Wiring Diagram: Single Remote Dispenser, Gasboy Reset

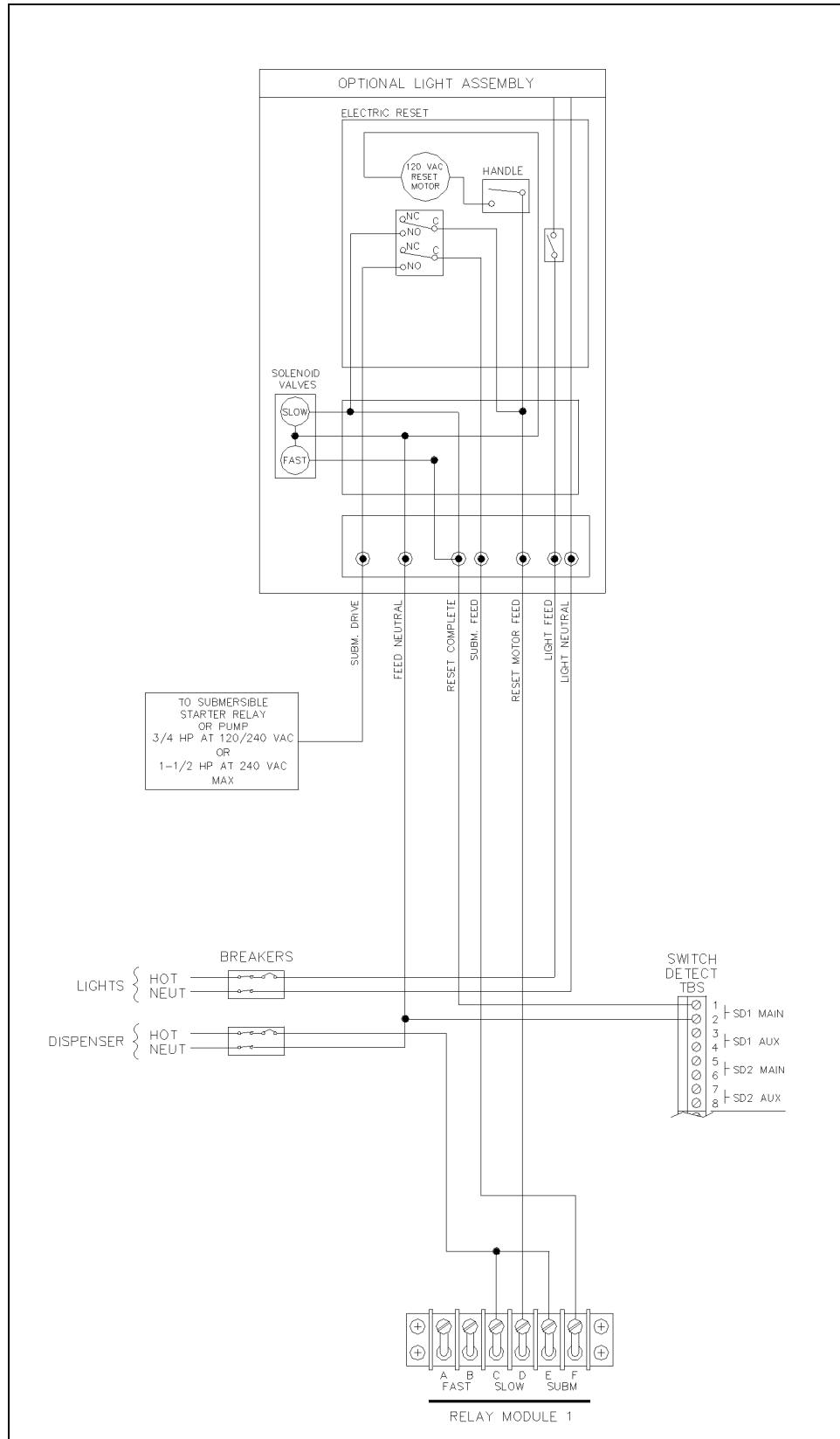
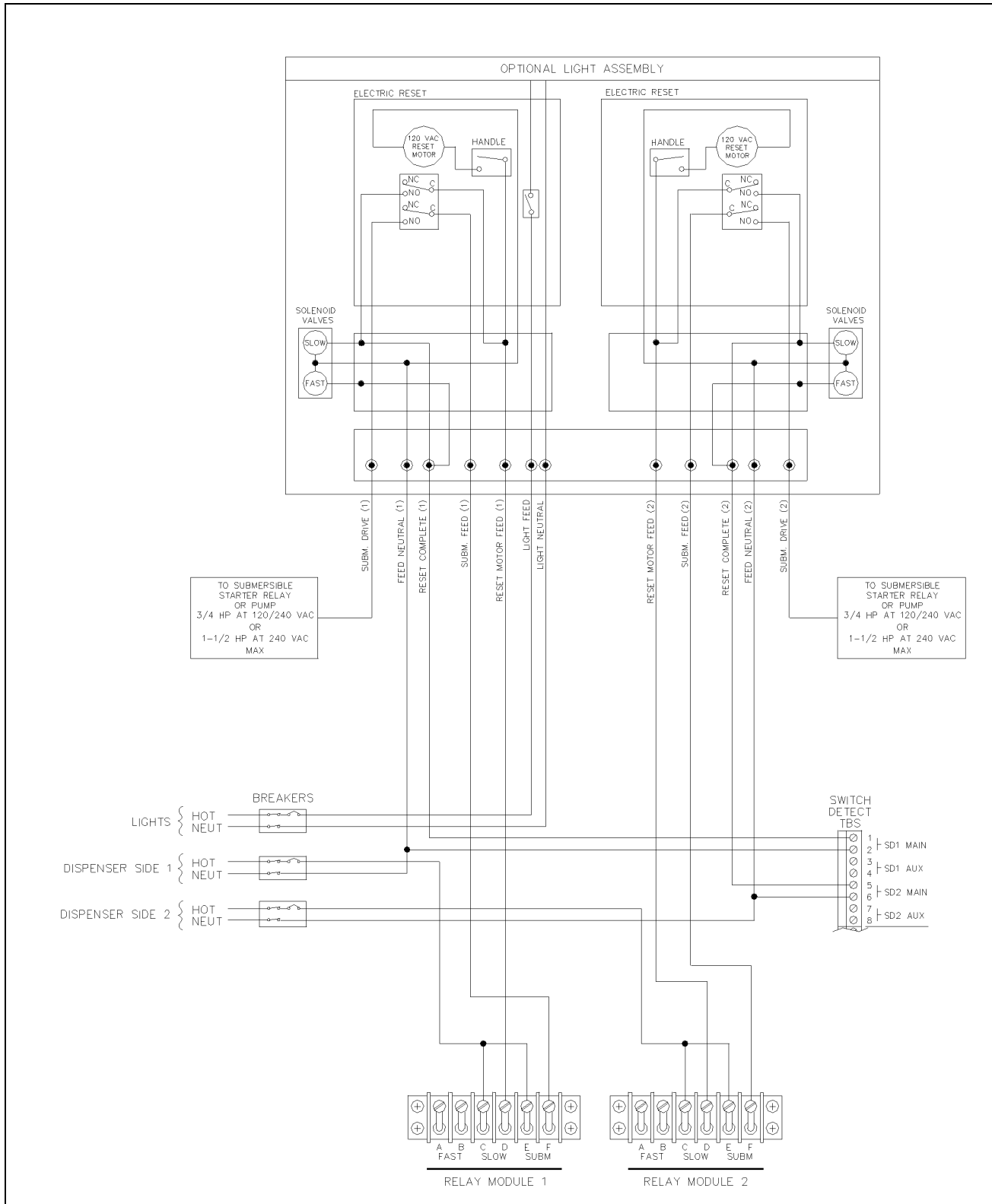

Figure 8-20: Wiring Diagram: Twin Remote Dispenser, Gasboy Reset



Wiring Diagrams: Port Communication

The following diagrams show the pin-to-pin layout of the possible wiring schemes for the TopKAT system ports. Each Port may be wired for any of the wiring schemes, provided the installation requirements are met as outlined at [“Communication Requirements”](#) on [page 19](#).

Figure 8-21: Wiring Diagram: RS-232 - D Connector

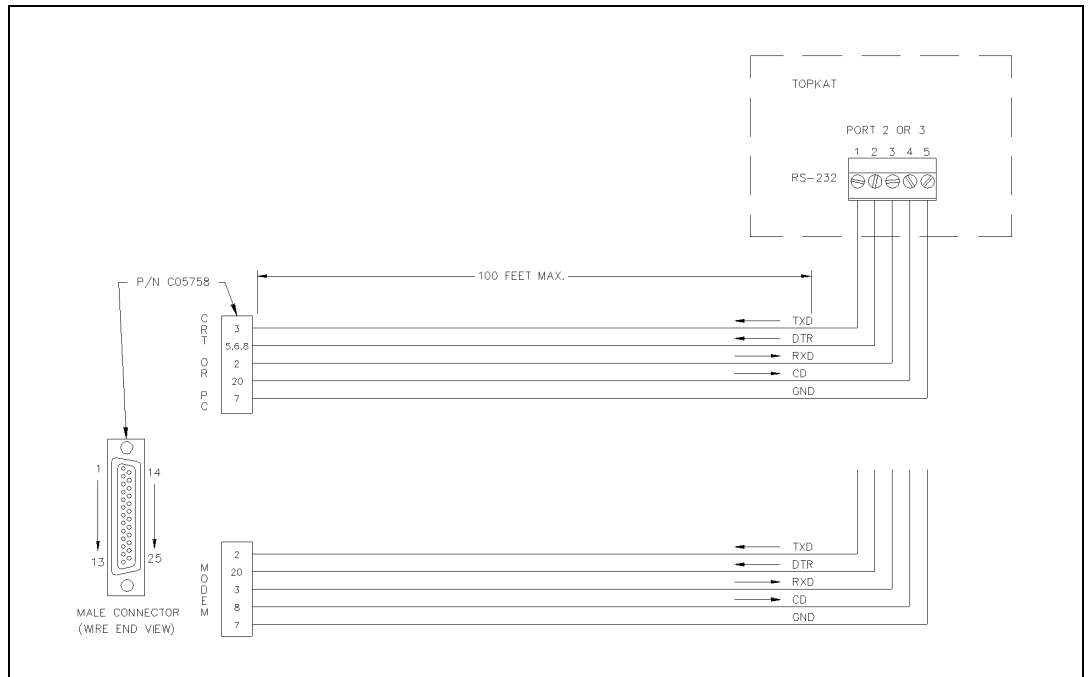

Note: In the TopKAT system, the green connector must be connected to P4 on the communication board for Port 2, and P6 for Port 3. The K1 and K2 jumper for the Port being used should be set to RS-232. Refer to [“Terminal Block ID”](#) on [page 80](#) for the location of K1 and K2 jumpers.

Figure 8-22: Wiring Diagram: RS-485 - Communication Cable - TopKAT to Wall-mount (Remote) Mechanical PCU

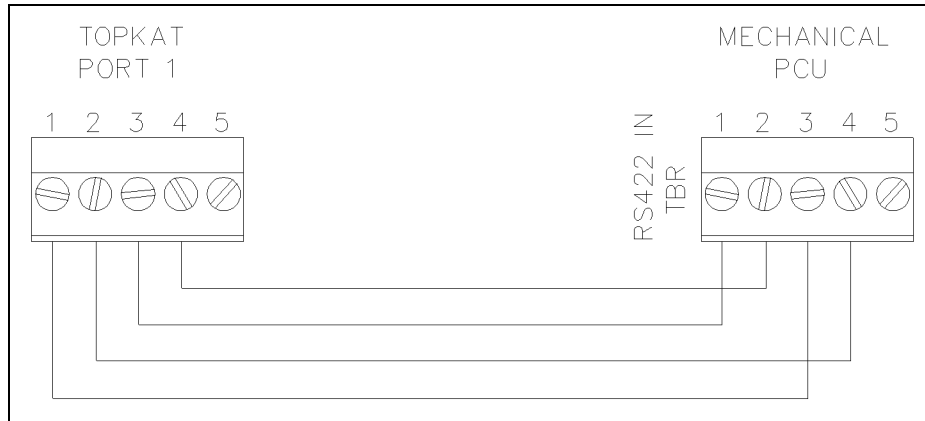
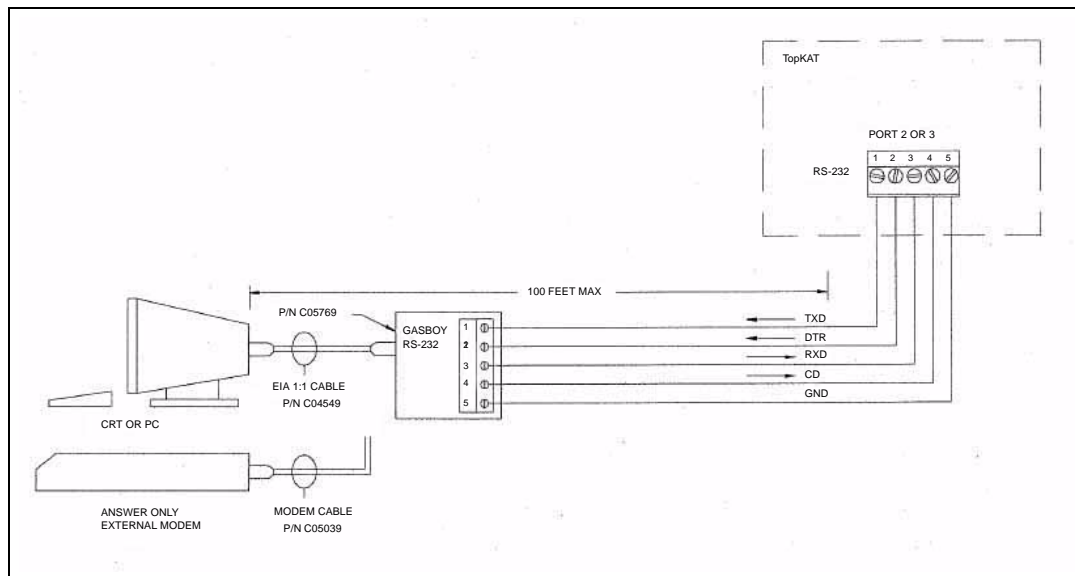
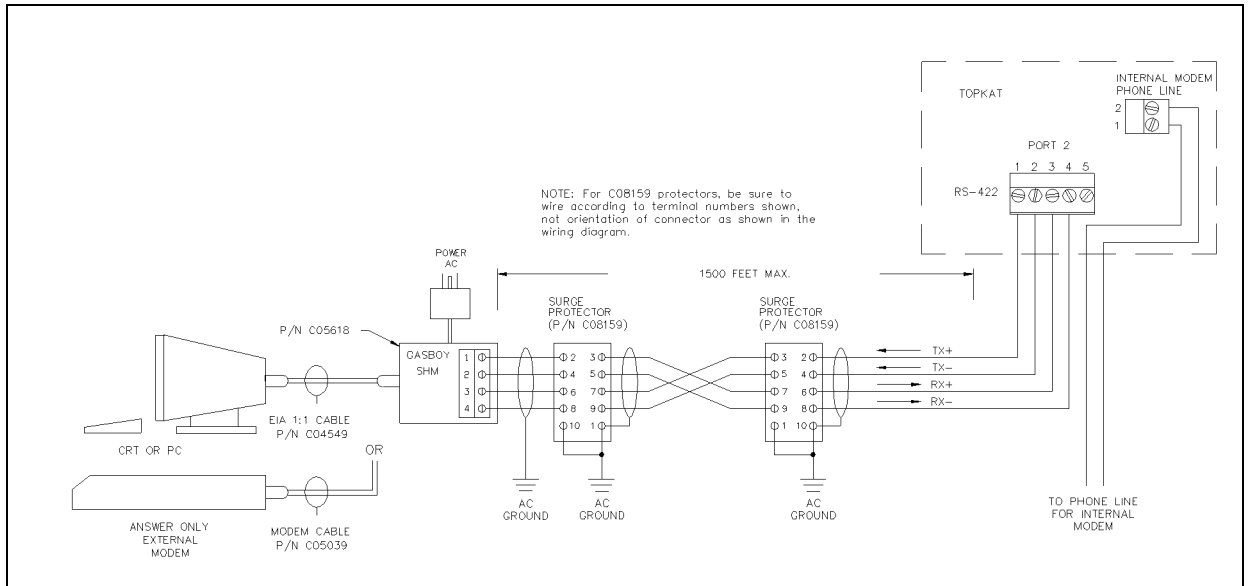

Figure 8-23: Wiring Diagram: RS-232 - Gasboy Termination Box



Note: In the TopKAT system, the green connector must be connected to P4 on the communication board for Port 2, and P6 for Port 3. The K1 and K2 jumper for the Port being used should be set to RS-232. Refer to “Terminal Block ID” on page 80 for the location of K1 and K2 jumpers.

Figure 8-24: Wiring Diagram: RS-422 - Gasboy Short Haul Modem



Notes: 1) In the TopKAT system, the green connector must be connected to P3 on the communication board for Port 2, and P5 for Port 3.

2) In cases where a TopKAT internal modem is used, Port 3 is not available for external communication wiring.

3) The K1 and K2 jumper for the port being used should be set to RS-422. Refer to "Terminal Block ID" on page 80 for the location of K1 and K2 jumpers.

Figure 8-25: Wiring Diagram: Internal Modem

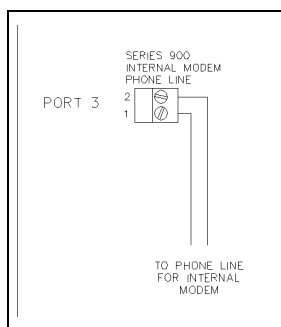

Notes 1) In cases where a TopKAT internal modem is used, Port 3 is not available for external communication wiring.

2) The K2 jumper for Port 3 should be removed. Refer to "Terminal Block ID" on page 80 for the location of the K2 jumper.

TopKAT Master/Satellite Communications Wiring

Figure 8-26: Wiring Diagram: TopKAT Master, 2 TopKAT Satellites, 2 Wall-mount PCUs

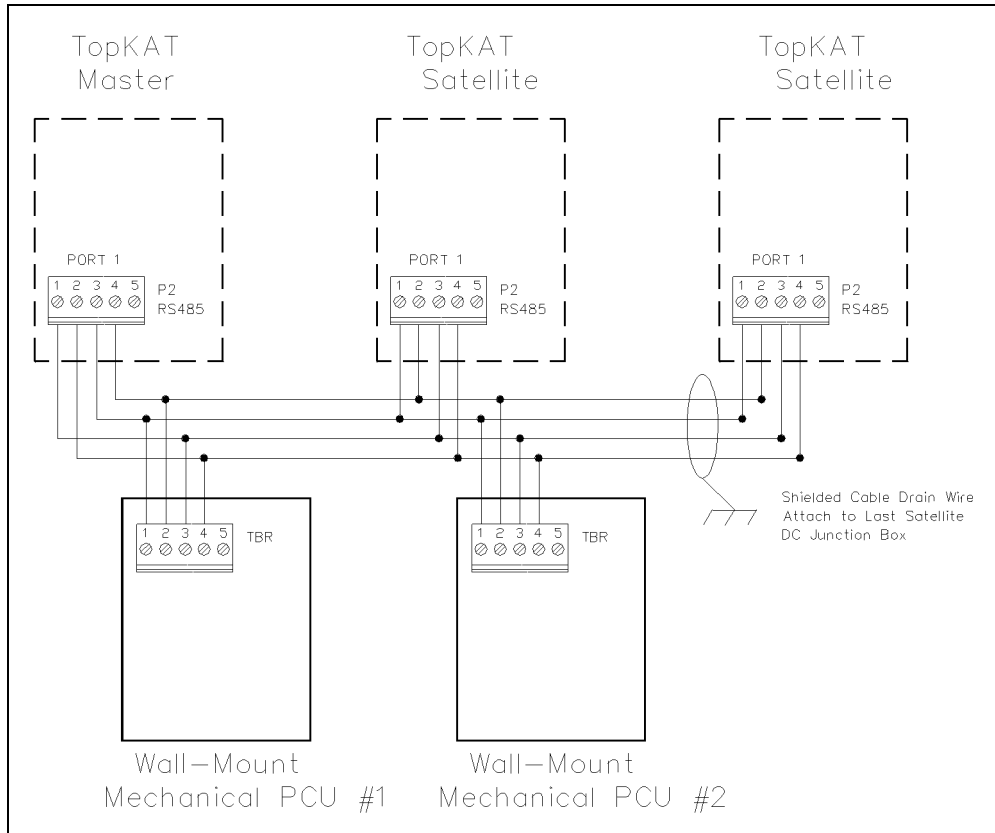

Wiring for a CRT Terminal and Okidata Printer

Figure 8-27 shows the connections between the TopKAT system port, a CRT terminal, and the Okidata printer.

Figure 8-27: TopKAT Port to CRT to Okidata Printer Connections

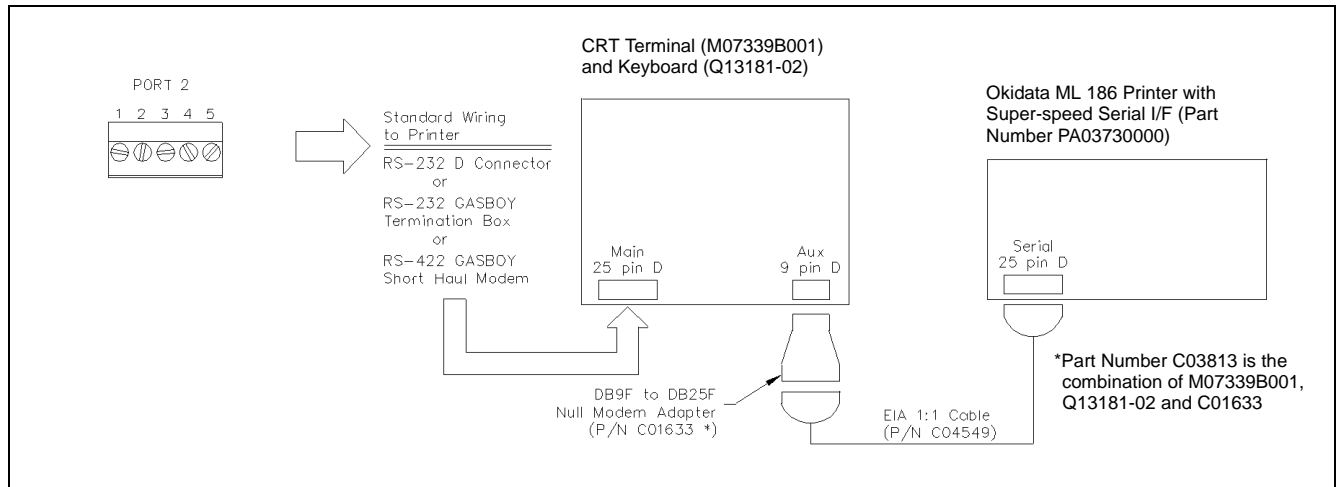

Wiring for Modems

External Modems

The type of phone line required for communication via an external modem depends upon the type of modem used and the method of communication desired. Refer to the manual that is provided with the modem, for specific requirements.

Internal Modem

When the TopKAT internal modem is installed, Port 3 communication is routed through the modem instead of being wired at the DC Junction box. Jumper K2 should be removed. Refer to "Terminal Block ID" on page 80 for the location of jumpers K1 and K2. The phone line for the internal modem can be installed in the DC conduit. If you are installing it in the DC conduit, the cable must be two twisted-pair shielded cable as specified in "Communication Requirements" on page 19 and the shield drain wire must be connected to the system AC ground. Check with your local phone company for proper installation of the phone line.

This page is intentionally left blank.

9 – Series 9800 Field Installation

Description

When the TopKAT system is interfaced with an existing 9800 Series pump/dispenser, it cannot be mounted on top of the pump/dispenser. Instead, the TopKAT is mounted on top of a 50 inch high standalone pedestal. All wiring connections are made within the TopKAT. Electronics or control devices are not present in the pedestal.

The TopKAT communicates with the 9800 Series pump/dispenser (single or twin) through the first of its three asynchronous Ports. Port 1 is a dedicated RS-485 communication loop which allows the TopKAT to control all functions of the 9800. Ports 2 and 3 can be set for either RS-232 or RS-422 communications to a data terminal or computer. Refer to [“Communication Requirements”](#) on [page 19](#) for wiring considerations.

Figure 9-1: Series 9800 Dimensions

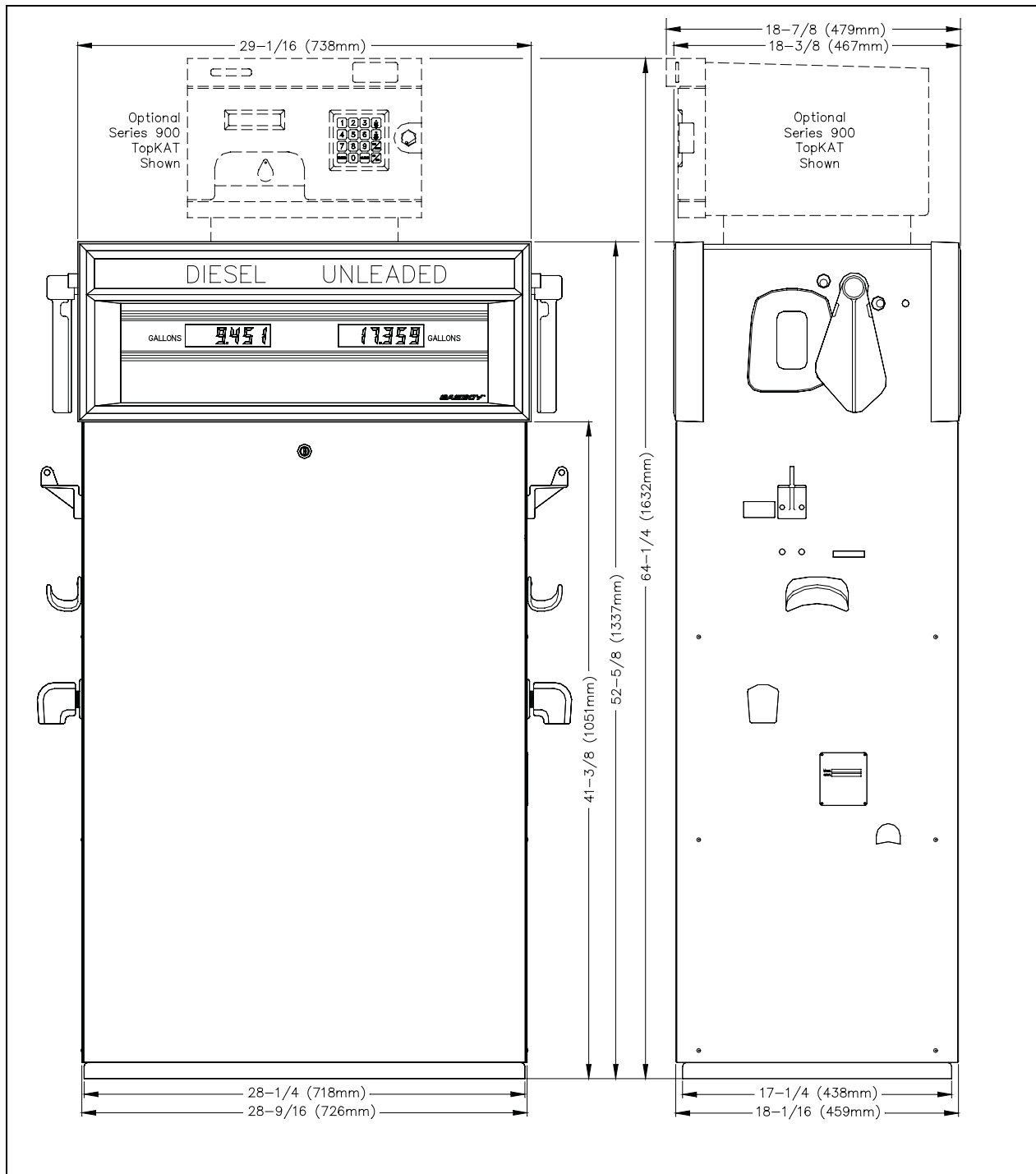

Conduit Layout

Note: Refer to "General Installation" on page 11 for conduit, power requirements, and wire size considerations.

Figure 9-2: Series 9800 Conduit Layout

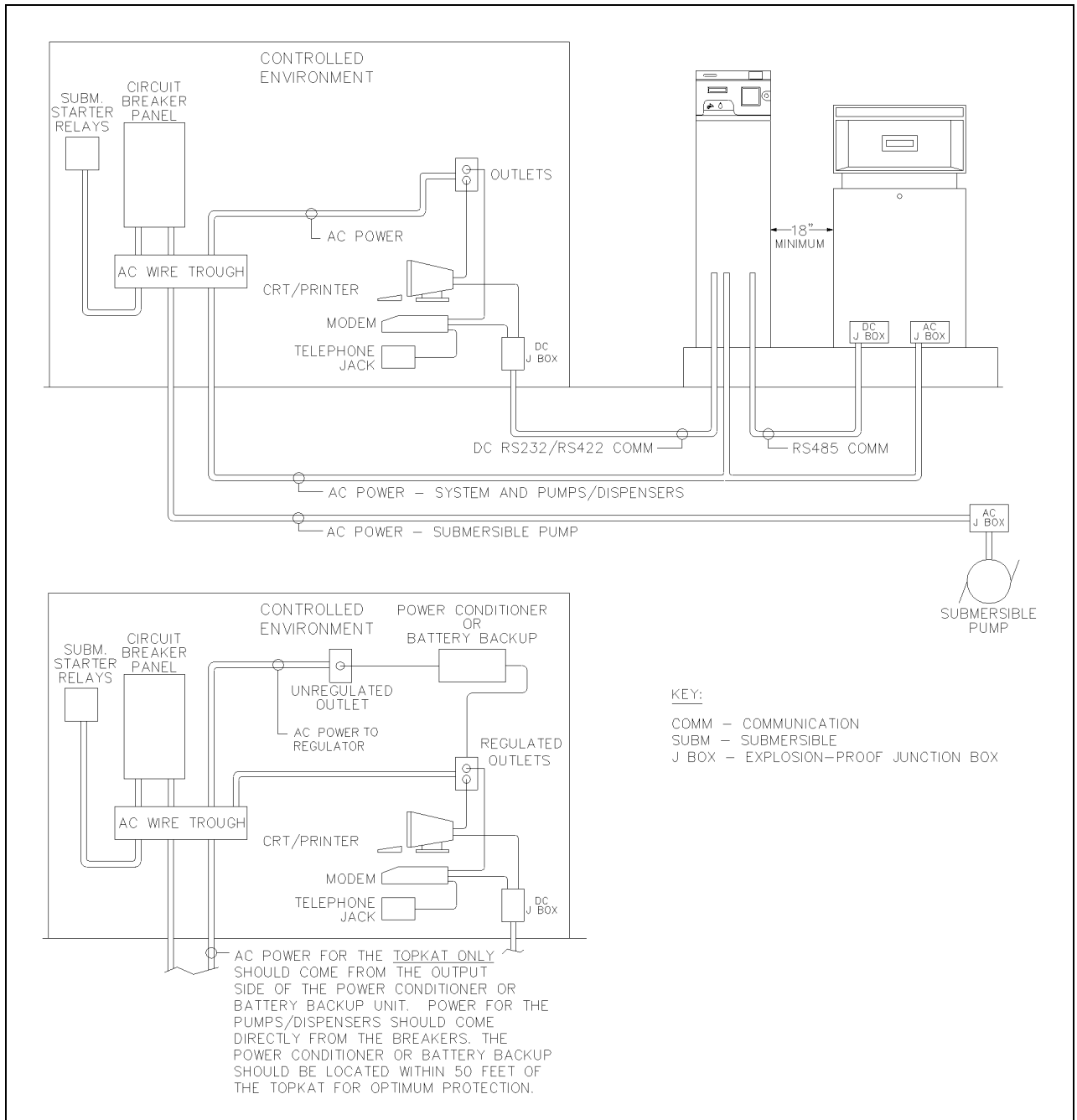

Series 9800 to TopKAT Cabling

The interconnection of the 9800 Series pump/dispenser to the TopKAT requires a single RS-485 communication cable. Refer to “[Communication Requirements](#)” on [page 19](#) for wiring considerations.

Figure 9-3: RS-485 Communication Cable

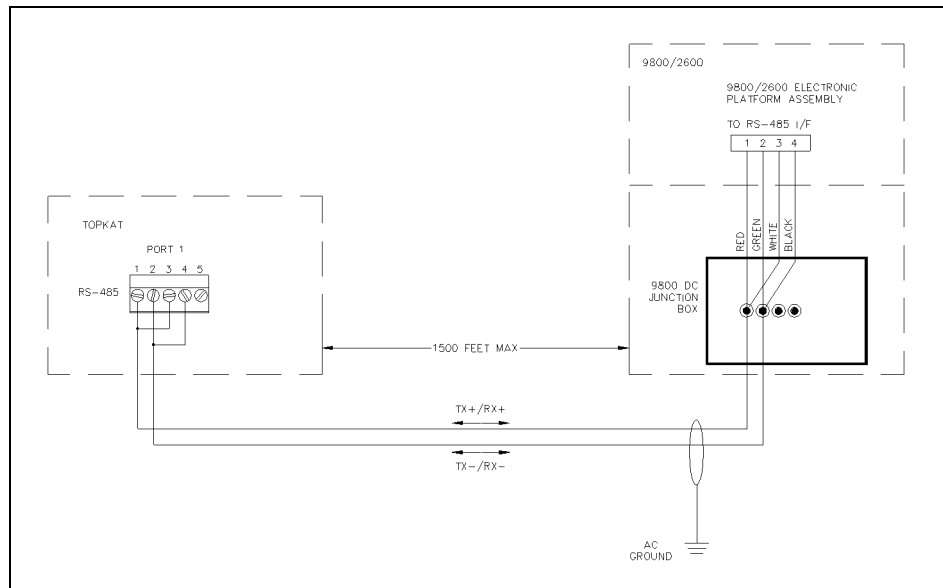

For 9800 Series switch settings, access, and location, refer to “[Appendix B: Atlas CPU Board Jumper Settings](#)” on [page B-1](#) and MDE-4334 Atlas™ Start-up/Service Manual.

Port Communication Wiring

The following diagrams show the pin-to-pin layout of the possible wiring schemes for the TopKAT ports. Each port may be wired for any of the wiring schemes, provided the installation requirements are met as outlined in [“Communication Requirements”](#) on page 19.

Figure 9-4: RS-232 - D Connector

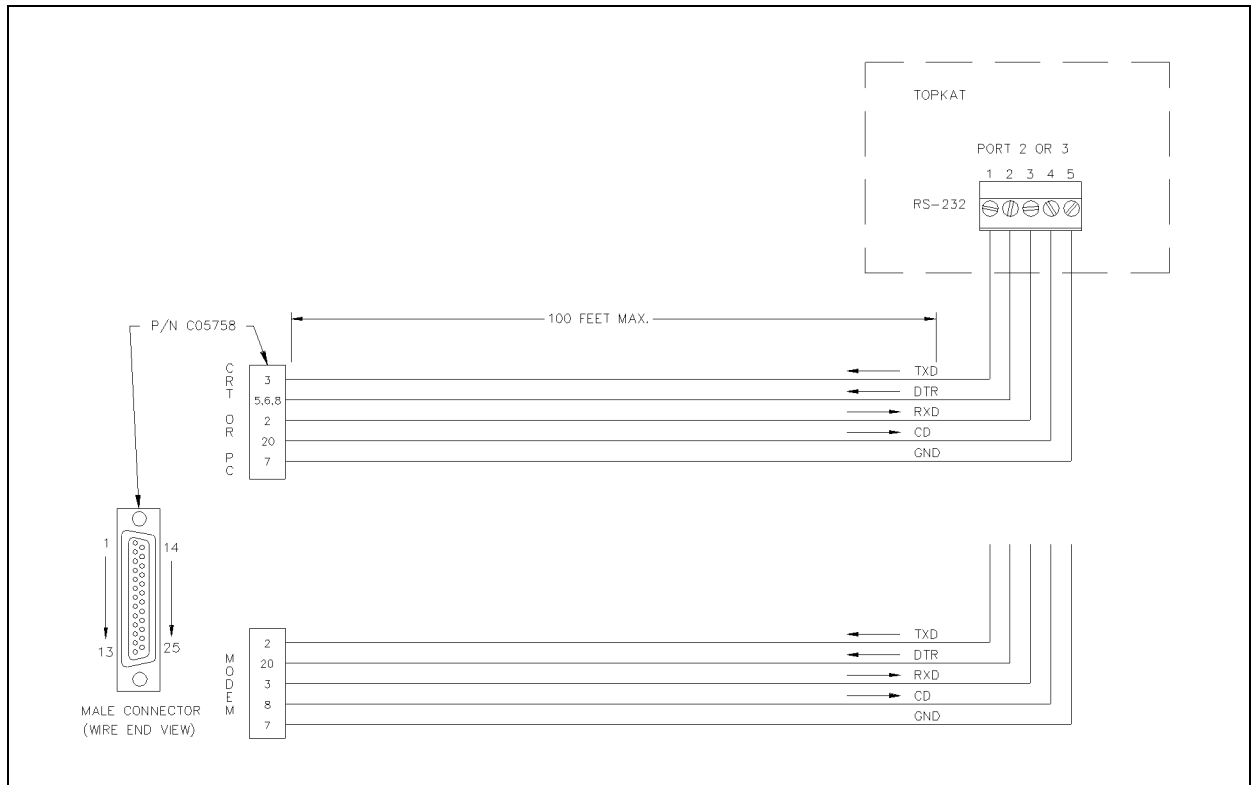

Note: In the TopKAT, the green connector must be connected to P4 on the communication board for Port 2, and P6 for Port 3. The K1 and K2 jumper for the port being used should be set to RS-232. Refer to [“Terminal Block ID”](#) on page 24 for the location of K1 and K2 jumpers.

Figure 9-5: RS-232 - Gasboy Termination Box

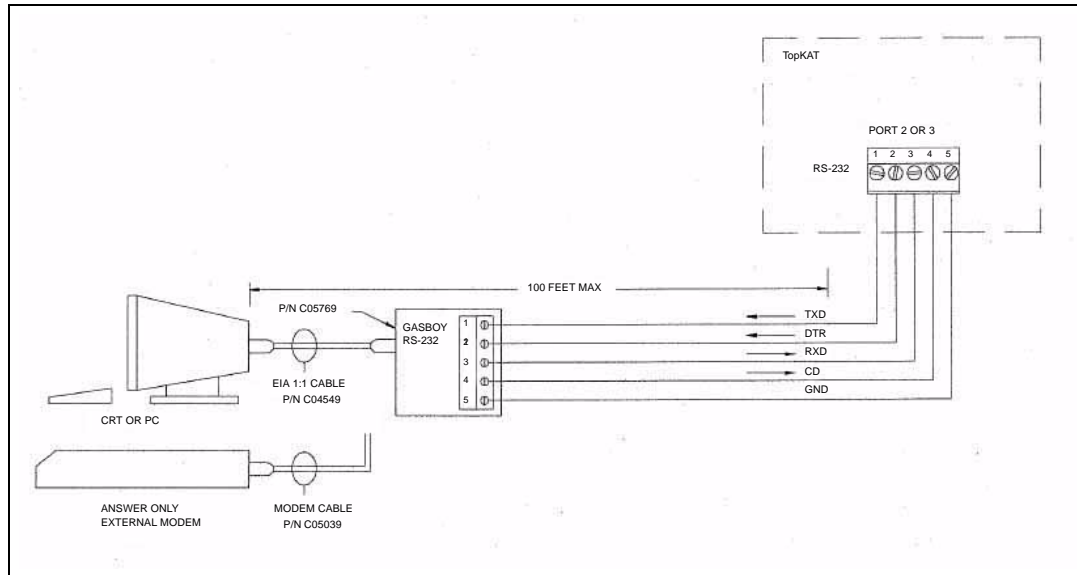

Note: In the TopKAT, the green connector must be connected to P4 on the communication board for Port 2, and P6 for Port 3. The K1 and K2 jumper for the port being used should be set to RS-232. Refer to “Terminal Block ID” on page 24 for the location of K1 and K2 jumpers.

Figure 9-6: RS-422 - Gasboy Short Haul Modem

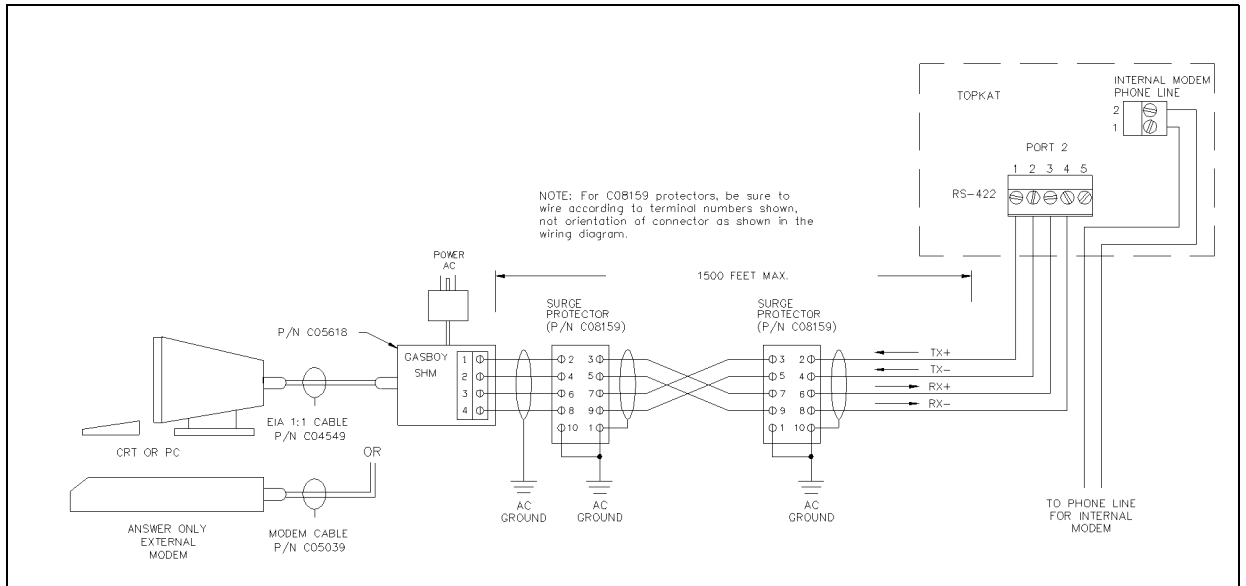

Notes: 1) In the TopKAT, the green connector must be connected to P3 on the communication board for Port 2, and P5 for Port 3.

2) If a TopKAT internal modem is used, Port 3 is not available for external communication wiring.

3) The K1 and K2 jumper for the port being used should be set to RS-422. Refer to “Terminal Block ID” on page 24 for the location of K1 and K2 jumpers.

Figure 9-7: Internal Modem

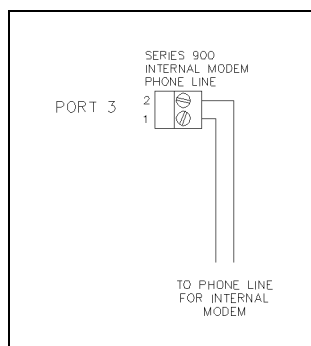

Notes: 1) If a TopKAT internal modem is used, Port 3 is not available for external communication wiring.

2) The K2 jumper for Port 3 should be removed. Refer to “Terminal Block ID” on page 24 for the location of the K2 jumper.

TopKAT Master/Satellite Communications Wiring

Figure 9-8: 2 Top-mounted TopKATs with Short Haul Modem and 1 Series 9800

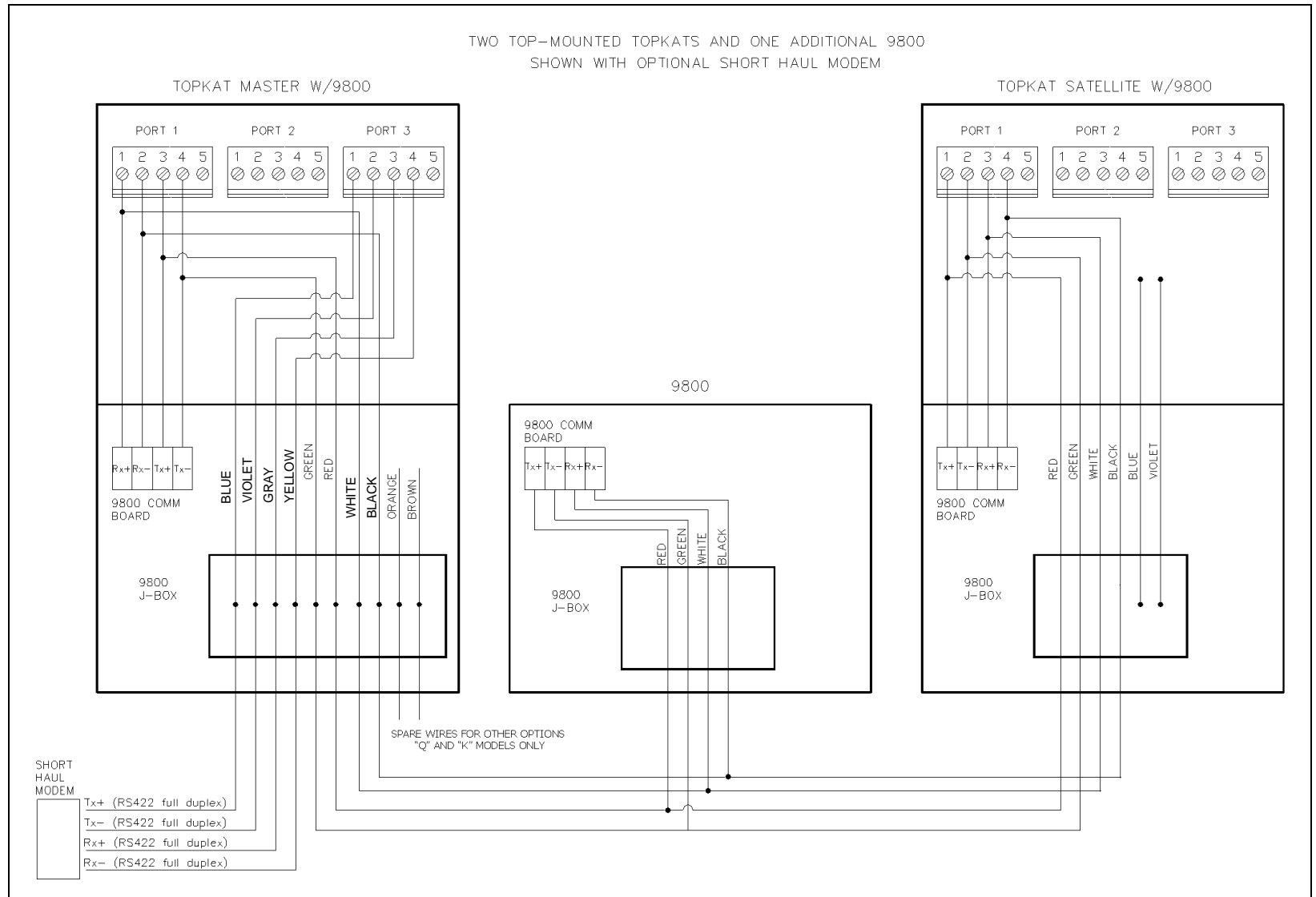

Wiring for a CRT Terminal and Okidata Printer

The following diagram shows the connections between the TopKAT port, a CRT terminal, and the Okidata printer.

Figure 9-9: Wiring Diagram: TopKAT Port, CRT, and Okidata Printer

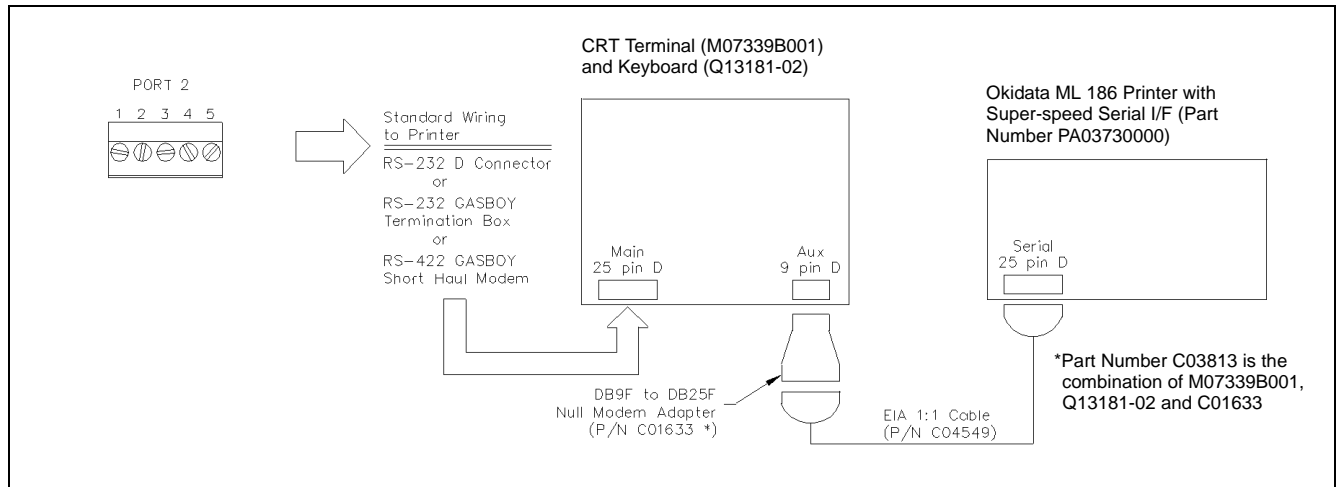

Wiring for Modems

External Modems

The type of phone line required for communication via an external modem depends upon the type of modem used and the method of communication desired. Refer to the manual that is provided with the modem, for specific requirements.

Internal Modem

When the TopKAT internal modem is installed, Port 3 communication is routed through the modem in place of being wired at the DC Junction box. Jumper K2 should be removed. Refer to “[Terminal Block ID](#)” on [page 24](#) for location of jumpers K1 and K2. The phone line for the internal modem can be installed in the DC conduit. If you are installing it in the DC conduit, the cable must be two twisted-pair shielded cable as specified in “[Communication Requirements](#)” on [page 19](#) and the shield drain wire must be connected to the system AC ground. Check with your local phone company for proper installation of the phone line.

This page is intentionally left blank.

10 – Wireless Communications Installation

The primary reason to use wireless communications between the TopKAT system and a polling system is to avoid the need of digging a trench and installing metal conduit for communication wires. The wireless communications is accomplished by using a modem and antenna at each end (Figure 10-1). The distance between the TopKAT system and polling system can be up to 3 miles (4.8 kilometers).

The wireless communications option cannot provide or extend communications between the following devices:

- Island Card Readers (ICRs)
- 9800 Series pumps/dispensers
- Gasboy PCUs
- Other manufacturers' electronic pumps
- Credit card network communications

Figure 10-1: TopKAT Wireless System - Directional Antenna at Each End

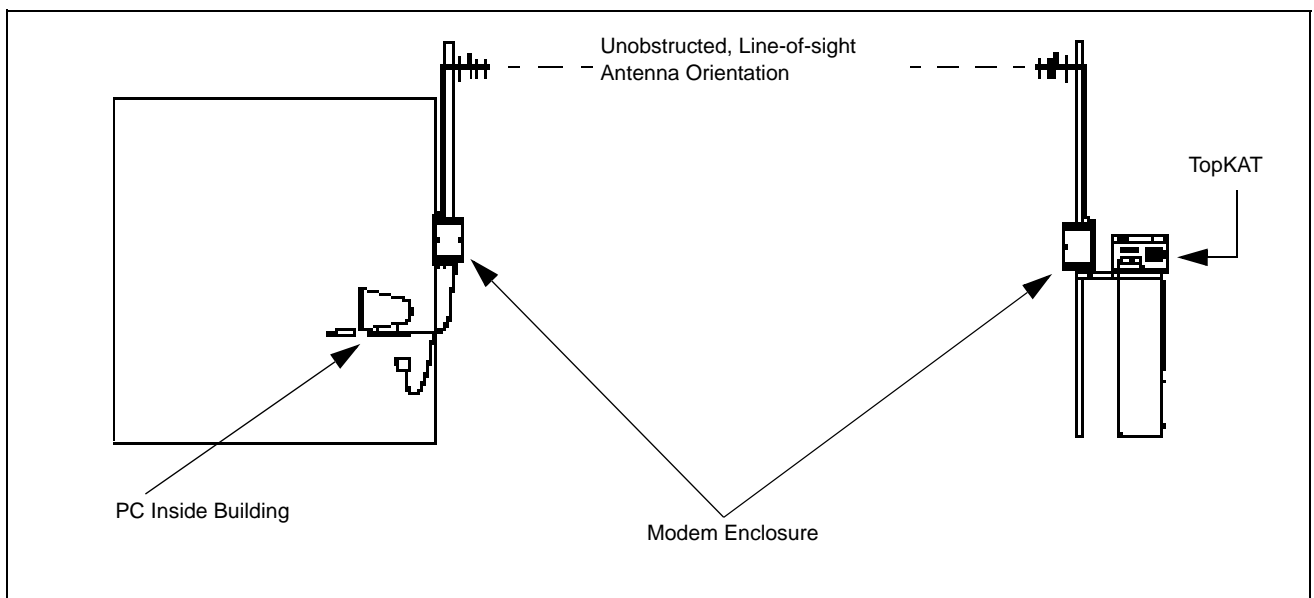

For more information on TopKAT Wireless Communications Installation, refer to MDE-4520 Enhanced Communications Installation Manual.

This page is intentionally left blank.

11 – Serial-to-LAN Connection Installation

A serial-to-LAN converter (Figure 11-1) can be used (Figure 11-2 on page 124) to connect to the TopKAT over a LAN and/or over the Internet. With the appropriate configuration, the TopKAT can be polled via the serial to LAN converter using the Gasboy polling software. Refer to MDE-4520 Enhanced Communications Installation Manual for more specific information regarding installation of this device with TopKAT and other Gasboy fuel management systems.

Figure 11-1: Serial-to-LAN Converter

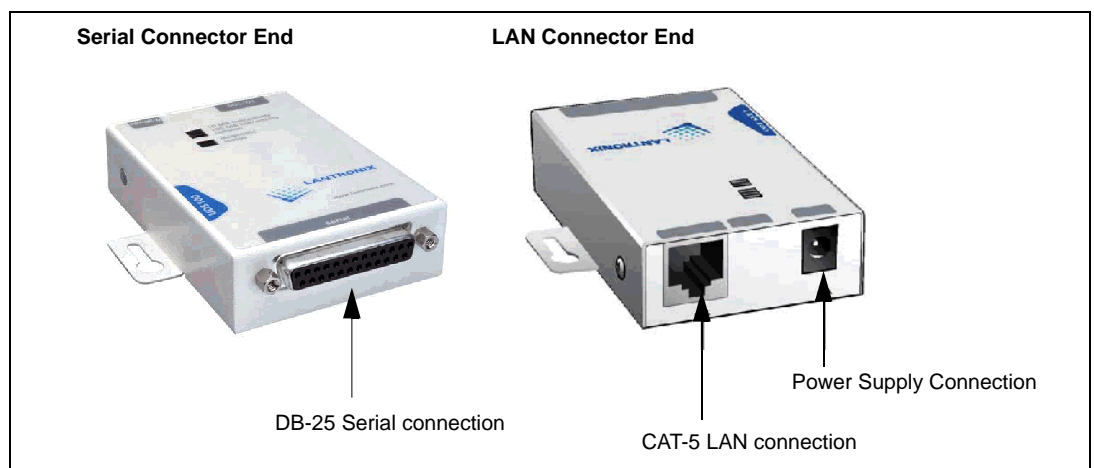
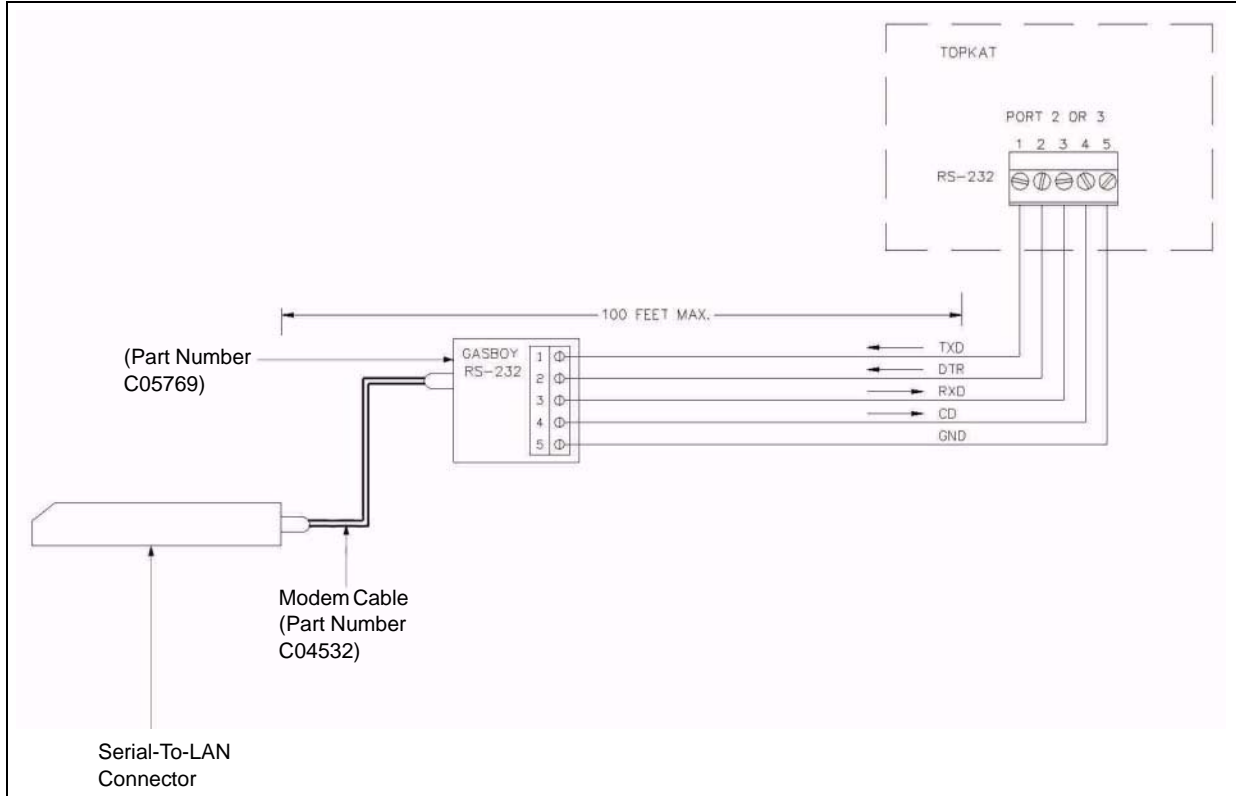

Figure 11-2: Gasboy Termination Box



For more information on the TopKAT serial-to-LAN connection, refer to the following:

- 900-360 Lantronix® UDS-10 UDS-100 User Guide (http://www.lantronix.com/pdf/UDS10-UDS100_UG.pdf)
- 900-363 Lantronix UDS-10, UDS100, UDS200 Quick Start Guide (http://www.lantronix.com/pdf/UDS10-100-200_QS.pdf)
- MDE-4338 TopKAT Fuel Management System Operation Manual
- MDE-4520 Enhanced Communications Installation Manual

12 – Testing

Completion Check List

The information below will help verify if the TopKAT system is properly installed. Review it before testing the pumps and/or dispensers in the manual override position.

- Is the optional data terminal located in a clean, office-type environment?
- Is the optional external modem located in an office-type environment or a protective enclosure?
- Is all the wiring in metal conduit? (refer to “[Conduit Requirements](#)” on [page 14](#)). The only exception to the metal conduit rule is RS-422 as noted in “[RS-422 - SHMs](#)” on [page 22](#).
- Is the AC and DC wiring in separate conduits, troughs, and so on - except as noted in “[RS-422 - SHMs](#)” on [page 22](#)?
- Is the system/peripheral equipment on a separate dedicated breaker? (refer to “[Power Requirements](#)” on [page 16](#)).
- Is the system grounded properly? (refer to “[Power Requirements](#)” on [page 16](#)).
- Is the correct gauge wire installed for the communication lines? (“[Wire Size](#)” on [page 17](#))
- Are the communication lines under the maximum allowable distance?
 - RS-232: 100 feet
 - RS-422: 1500 feet except as noted in “[RS-422 - SHMs](#)” on [page 22](#).
- If the system has an internal modem, is the phone line installed? (“[Internal Modem](#)” on [page 13](#))

Manual Override Test - 2-hose Mechanical Interface Option

Note: The manual override test can only be performed on pumps/remote dispensers that are connected to the TopKAT Mechanical Interface.

The pumps and/or remote dispensers should be tested to verify AC wiring.

Note: Power up only the TopKAT system during these tests.

The following steps indicate the proper procedure for testing and the expected results. If any of these tests fail, correct the wiring and re-do the test. Refer to “[Terminal Block ID](#)” on [page 42](#) for the location of the override switches.

- 1 Remove all wiring connectors (green) from the Pump Control PCB assembly located in the rear of the TopKAT system. This will prevent any damage to the PCB if the wiring is incorrect.
Note: Ensure that the connectors are not touching any metal surfaces.
- 2 Turn on the breakers for all pumps and/or remote dispensers. If the TopKAT system and other components are powered from the same breaker, ensure that the other components are switched off before proceeding. Turn on the breaker to the TopKAT system.

WARNING

AC power is present on the terminal blocks of the relay modules. Electrical shock may occur if the operator comes in contact with these connections.

AVERTISSEMENT

Le courant alternatif est sous tension sur les bornes des modules de relais. Un choc électrique peut se produire si l'opérateur entre en contact avec ces connexions.

- 3 In the TopKAT system, turn the AC power switch to the **ON** position (up).
- 4 Place the system override switch (SW1) for hose #1 in the **MAN** position.
- 5 Turn on hose 1. After completing reset, the hose should be able to dispense product.
- 6 Turn on all other hoses. No other hoses should be able to dispense the product.
- 7 Turn off all hoses.
- 8 Place the system override switch for hose 1 in the **AUTO** position.
- 9 Repeat steps 4 through 8 for all remaining hoses. Substitute the hose under test for hose 1.
- 10 Turn off the AC power switch in the TopKAT system.
- 11 Turn off the breakers for all pumps and/or remote dispensers and the TopKAT system and other components.

- 12 Replace all wiring connectors (green) removed in step 1 from the Pump Control PCB assembly.

Note: The manual override test will uncover most point-to-point AC wiring mistakes that can occur. The automatic test performed during the system start-up will complete the verification of correct AC wiring to the pump/remote dispensers. The automatic test should only be performed at start-up.

Manual Override Test - 4-hose Mechanical PCU Option

Note: The manual override test can only be performed on pumps/remote dispensers that are connected to the 4-hose Mechanical PCUs.

The pumps and/or remote dispensers should be tested to verify AC wiring.

Note: Power up only the PCUs during these tests.

The following steps indicate the proper procedure for testing and the expected results. If any of these tests fail, correct the wiring and re-do the test. Refer to “[Terminal Block ID](#)” on [page 80](#) for the location of the override switches.

- 1 Remove all wiring connectors (green) from the Pump Control I/O PCB assembly located in the front of the card cage. This will prevent any damage to the PCBs if the wiring is incorrect.
Note: Ensure that the connectors are not touching any metal surfaces.
- 2 Turn on the breakers for all pumps and/or remote dispensers. If the TopKAT system and other components are powered from the same breaker as the PCU, ensure that they are switched off before proceeding.

WARNING

AC power is present on the terminal blocks of the relay modules. Electrical shock may occur if the operator comes in contact with these connections.

AVERTISSEMENT

Le courant alternatif est sous tension sur les bornes des modules de relais. Un choc électrique peut se produire si l'opérateur entre en contact avec ces connexions.

- 3 In the PCU, turn the AC power and battery power switches to the **ON** position (up). These switches are located in the upper right-hand corner of the power supply.
- 4 Place the system override switch for hose #1 in the **MAN** position.
- 5 Turn on hose 1. After completing reset, the hose should be able to dispense the product.
- 6 Turn on all other hoses. No other hoses besides hose 1 should activate.

- 7 Turn off all hoses.
- 8 Place the system override switches for hose 1 in the **ON** position.
- 9 Repeat steps 4 through 8 for all remaining hoses. Substitute the hose under test for hose 1.
- 10 Turn off the AC power and battery power switches in the PCU.
- 11 Turn off the breakers for all the pumps and/or remote dispensers and the TopKAT system and other components.
- 12 Replace all wiring connectors (green) removed in step 1 from the Pump Control I/O PCB assembly.

Note: The manual override test will uncover most point-to-point AC wiring mistakes that can occur. The automatic test performed during the system start-up will complete the verification of correct AC wiring to the pump/remote dispensers. The automatic test should only be performed at start-up.

Appendix A: Base Layout for Shelf Mounting

The TopKAT system can be mounted on a shelf of your own design, if desired. If you choose to do this, use the following base layout, in addition to following all installation precautions and instructions for your system type as outlined in the earlier sections of this manual.

Figure A-1: Base Layout for TopKAT Shelf Mounting

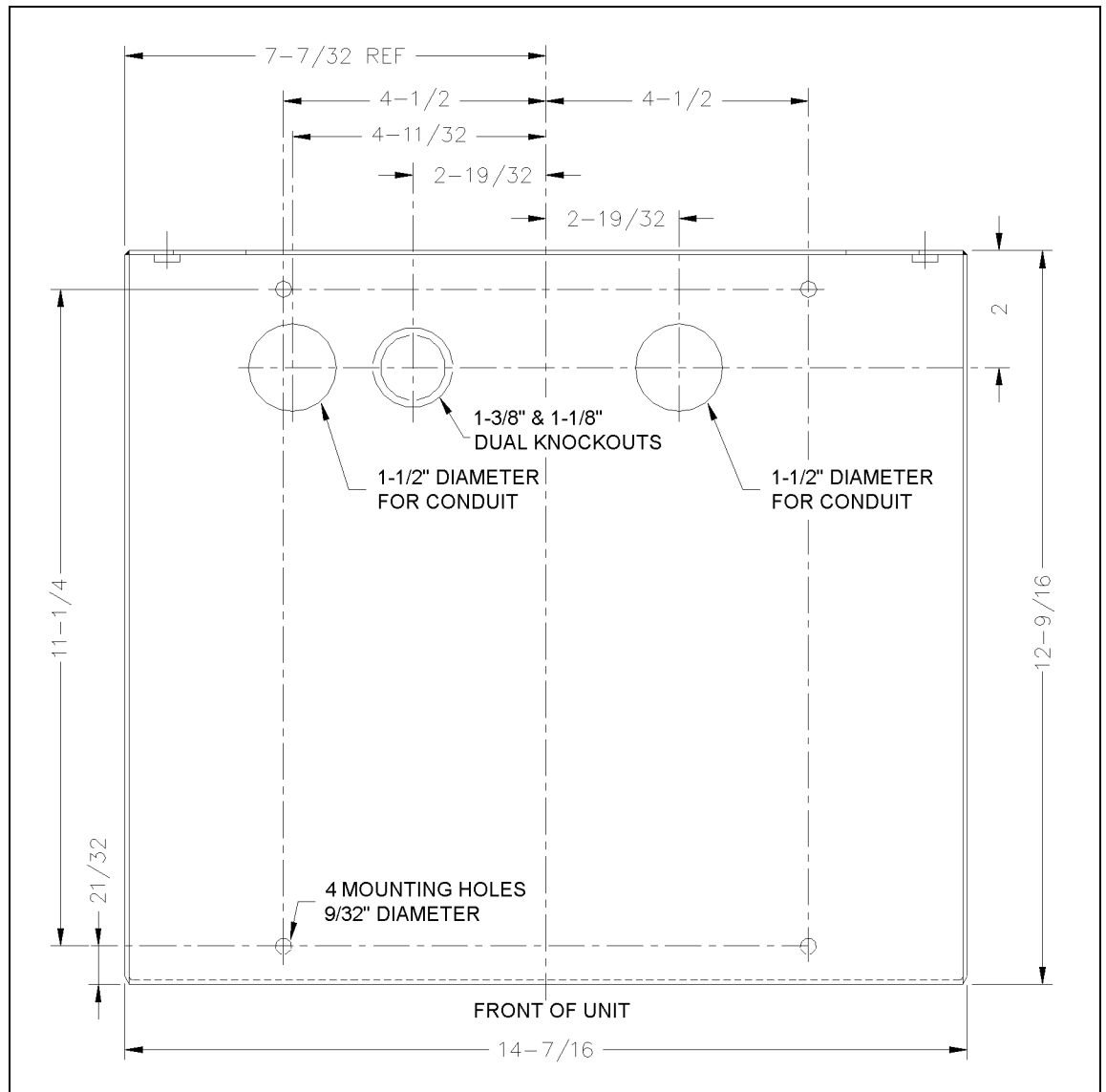

This page is intentionally left blank.

Appendix B: Atlas CPU Board Jumper Settings

Note: This appendix only describes the jumpers and switch settings necessary for the Gasboy TopKAT System to function in conjunction with Gasboy Commercial Pumps and Dispensers. Other jumpers and switches exist that control features and functions of the pump and/or dispenser. For more information on these jumpers and switches, refer to MDE-4652 Atlas 9800 Electronics Field Installation Instructions.

Old Style (C09634)

Switch Settings

For the ASTRA and 9800 Series pump/dispenser to communicate with the TopKAT system via RS-485, the switch settings on the ASTRA or 9800 CPU must be set as follows:

Switch	Function	Position/Setting
SW1-1	Baud Rate Switch	Open (9600 baud)
SW1-2	Mode Switch	Open (on-line)
SW1-8	RS-485 Pump Stop Detection	Closed (disabled)
SW2-1 through SW2-4	Address	Closed (address 1)

New Style CPU (M06333)

Jumper/Switch	Position/Setting
JP1	Open (9600 baud)
JP2	Open (on-line)
JP8	Jumpered (Pump Stop on RS-485 break disabled)
SW1-4	Closed (address 1)

This page is intentionally left blank.

Index

A

Alert symbol 5
 AVERTISSEMENT 11, 43, 89

B

Barricading 5

C

CAUTION 10, 49, 88
 Caution warnings 5
 Completion Check List 125
 conduit
 trade size 15

D

Danger warnings 5
 Dimensions
 9800 112
 ASTRA 25
 PCU 77
 Pedestal 76
 TopKAT 2, 40
 document, referenced
 900-360 124
 900-363 124
 MDE-4338 124
 MDE-4520 3, 121, 124
 documents
 related 4

E

Electrical
 Shut-off 5
 Emergency
 Electrical shut-off 5
 In Case Of 7
 Personnel (contacting) 6
 Evacuation 5
 Explosions
 Preventing 5

F

Fires
 Preventing 5

G

gauge
 wire 15, 18

I

Installation
 Rules 11, 43, 89

M

Manual Override Test 126

N

New Style CPU (M06333 1

O

Old Style (C09634) 1

P

Personnel
 Emergency (informing) 6
 Precautions
 Wiring 43, 89

R

REN 9, 10
 ringer equivalence number 9, 10
 RS-
 232 21, 22, 28, 29, 69, 70, 105,
 106, 115, 116, 125
 RS-422 22, 29, 36, 71, 107, 117, 125
 RS-485 19, 20, 27, 33, 85, 106, 114

S

Safety Information 5
 Alert symbol 5
 Barricading 5
 Emergency electrical shut-off 5
 Emergency personnel 6
 Evacuation 5
 NFPA regulations 5
 Open flames 5
 Preventing explosions and fires 5
 Regulations 5
 Replacement parts 5
 Safety symbols 5
 Shut-off 5
 Signal words 5
 Smoking 6
 Sparks 6
 Warning words 5
 Working alone 6
 Safety symbols 5

Settings

 Switch 85, 86, 1
 Shut-off 5
 Emergency electrical 5
 Signal words
 Safety 5
 Switch Settings 85, 86, 1

T

Terminal Block ID 24, 42, 80
 Testing
 Completion Check List 125
 Manual Override Test 126

W

WARNING 11, 43, 89
 Warning words 5
 Warnings 5
 warranty 10, 11
 wire
 gauge 15
 size 18
 Wiring
 Precautions 43, 89

Belden® is a registered trademark of Belden Technologies, Inc. Lantronix® is a registered trademark of Lantronix Corporation. Okidata® is a registered trademark of Oki Electric Industry Company, Ltd. Phillips® is a registered trademark of Phillips Screw Company. TopKAT™ is a trademark of Gasboy International. UL® is a registered trademark of Underwriters Laboratories Inc. Veeder-Root® is a registered trademark of Danaher Corporation.



GASBOY

© 2008 GASBOY

7300 West Friendly Avenue · Post Office Box 22087

Greensboro, North Carolina 27420

Phone 1-800-444-5529 · <http://www.gasboy.com> · Printed in the U.S.A.

MDE-4319E TopKAT™ Fuel Management System Installation Manual · August 2008